

LBP-2000

SERVICE MANUAL

REVISION 0

Canon

AUG. 2001

FY8-13HQ-000

COPYRIGHT © 2001 CANON INC

Use of this manual should
be strictly supervised to
avoid disclosure of confi-
dential information.

INTRODUCTION

This Service Manual provides basic facts and figures needed to service the laser beam printer LBP-2000 (hereafter, the Printer), performed to ensure initial product quality and performance.

The following options may be used in combination with the Printer:

- Universal Cassette UC-65
- Paper Feeder Unit PF-65
- Hard Disk HD-65
- Ether Board EB-65

This Service Manual also covers these options. For others, see their respective Service Manuals.

This Service Manual consists of the following chapters:

Chapter 1, 'Product Outline,' introduces features and specifications as well as how to install and use the Printer.

Chapter 2, 'Operation,' explains the principles of operation used in the mechanical/electrical systems of the Printer according to function as well as timing at which associated mechanisms operate.

Chapter 3, 'Mechanical System,' shows the mechanical construction of the Printer and how to disassemble/assemble and adjust its components.

Chapter 4, 'Troubleshooting,' indicates how to correct various faults and make checks/adjustments, and provides standards to follow.

APPENDIX contains a general timing chart, general circuit diagrams, and list of signals.

Changes made to the descriptions because of product improvement or the like will be communicated in the form of Service Information bulletins as they occur.

All service persons are expected to go through this Service Manual and Service Information bulletins for a full understanding of the Printer while equipping themselves with skills and knowledge used to identify and correct faults in the Printer.

CONTENTS

CHAPTER 1 PRODUCT OUTLINE

I. FEATURES	1-1	A. Points to Note About	
II. SPECIFICATIONS	1-2	Installation	1-9
A. Printer	1-2	B. Selecting the Site	1-9
B. Options	1-4	C. Unpacking and Installing ...	1-11
III. SAFETY	1-5	D. When Storing or Handling	
A. Safety of the Laser Unit	1-5	the EP-65 Cartridge	1-18
B. Safety of Toner	1-5	VI. RELOCATING THE PRINTER	1-21
C. Safety of Ozone	1-5	VII. ROUTINE MAINTENANCE/	
IV. NAMES OF PARTS	1-6	INSPECTION BY THE USER	1-22
A. External View	1-6	VIII. USING THE PRINTER	1-25
B. Cross Section	1-8	A. The Operation Panel	1-25
V. INSTALLATION	1-9	B. Operation Panel Menus	1-27
		C. Service Menu	1-28

CHAPTER 2 OUTLINE OF OPERATION

I. BASIC OPERATION	2-1	B. Printing Process	2-38
A. Functional Construction ...	2-1	V. PICKUP/FEEDING SYSTEM	2-46
B. Sequence of Basic		A. Outline	2-46
Operation	2-2	B. Detecting the Paper Size ...	2-49
C. Power-On Sequence	2-6	C. Using the Cassette	2-50
II. ENGINE CONTROL SYSTEM	2-7	D. Using the Multifeder	2-51
A. Outline of the Electrical		E. Fixing/Delivery	
Circuitry	2-7	Assembly	2-53
B. Inputs to and Outputs from		F. Detecting Jams	2-54
the DC Controller	2-9	VI. VIDEO CONTROL SYSTEM	2-59
C. Controlling the Fixing		A. Outline of the Electrical	
Mechanisms	2-12	Circuitry	2-59
D. High-Voltage Power Supply		B. Operation Panel	2-62
Circuit	2-18	C. Self Test	2-63
E. Low-Voltage Power Supply		VII. PAPER FEEDER	2-65
Circuit	2-23	A. Outline	2-65
F. Video Interface Control	2-25	B. Inputs to and Outputs from	
G. Other Control	2-27	the Paper Feeder	
III. LASER/SCANNER SYSTEM	2-30	Controller	2-66
A. Outline	2-30	C. Pickup/Feeding	
B. Laser Control Circuit	2-31	Operation	2-67
C. Scanner System	2-34	D. Detecting Jams	2-70
IV. IMAGE FORMATION SYSTEM ...	2-37		
A. Outline	2-37		

CHAPTER 3 MECHANICAL SYSTEM

I. EXTERNALS AND CONTROLS	3-1	B. Multifeeder Tray Pickup Assembly	3-20
A. External Covers	3-1	C. Registration Roller Assembly	3-23
B. Heat Discharging Fan	3-4	V. EXPOSURE MECHANISMS.....	3-25
C. Door Switch Assembly	3-5	A. Laser/Scanner Assembly	3-25
II. PCBS	3-8	VI. CHARGING/DEVELOPING/ CLEANING MECHANISMS	3-26
A. Arrangement of the PCBs...	3-8	A. EP-65 Cartridge	3-26
B. Video Controller PCB	3-8	B. Transfer Charging Roller	3-26
C. DC Controller PCB	3-12	VII. FIXING SYSTEM	3-27
D. Power Supply PCB Assembly	3-14	A. Fixing Assembly	3-27
III. DRIVE MECHANISMS	3-15	VIII. PAPER FEEDER	3-34
A. Main Motor	3-15	A. External Covers	3-34
B. Drive Assembly	3-16	B. Pickup Assembly	3-34
IV. FEEDING MECHANISMS	3-17	C. Drive Mechanism	3-38
A. Cassette Pickup Assembly	3-17	D. PCBs	3-39

CHAPTER 4 TROUBLESHOOTING

I. INTRODUCTION	4-1	VIII. MAINTENANCE AND INSPECTION	4-38
A. Troubleshooting Flow Chart	4-1	A. Periodically Replaced Parts	4-38
B. Making Initial Checks.....	4-4	B. Durables	4-38
C. Test Print	4-5	C. Scheduled Servicing	4-39
II. TROUBLESHOOTING IMAGE FAULTS	4-10	D. Points to Note for Cleaning	4-40
III. MEASURES AGAINST JAMS	4-17	E. Standard Tools	4-41
IV. FEEDING FAULTS.....	4-21	F. Special Tools	4-42
V. MALFUNCTIONS	4-23	G. Solvents and Oils	4-42
VI. CORRECTING A FAULT STATUS CONDITION	4-25	IX. ARRANGEMENT OF ELECTRICAL PARTS	4-43
VII. STANDARDS AND ADJUSTMENTS	4-31	A. Switches and Sensors	4-43
A. Making Mechanical Adjustments.....	4-31	B. Clutches, Solenoids, and Motors	4-45
B. Making Electrical Adjustments.....	4-32	C. Others	4-47
C. Copying the Counter Readings	4-33	D. PCBs	4-48
D. Variable Resistors (VR), Light- Emitting Diodes (LED), Check Pins, Jumpers, and Switches by PCB	4-34	E. Connectors	4-50

APPENDIX

I. GENERAL TIMING CHART	A-1	B. Inputs to and Outputs from the Paper Feeder Controller PCB	A-9
II. GENERAL CIRCUIT DIAGRAM ...	A-3	IV. MESSAGES TABLE	A-10
III. LIST OF SIGNALS	A-5		
A. Inputs to and Outputs from the DC Controller PCB.....	A-5		

CHAPTER 1

PRODUCT OUTLINE

I. FEATURES	1-1	VI. RELOCATING THE PRINTER	1-21
II. SPECIFICATIONS	1-2	VII. ROUTINE MAINTENANCE/ INSPECTION BY THE USER	1-22
III. SAFETY	1-5	VIII. USING THE PRINTER.....	1-25
IV. NAMES OF PARTS	1-6		
V. INSTALLATION.....	1-9		

I. FEATURES

1. High-speed printing

Although compact in design, the Printer is a high-speed printer capable of generating 20 pages per minute.

2. Various sources of paper with the addition of options

In addition to the cassette and the multifeder that come as standard, the Printer may be combined with three 250-sheet paper feeders (PF-65; hereafter, paper feeder) to enable 5-way pickup, each source with different types of paper.

3. Continuous printing of large volumes of work

As many as three option paper feeders may be installed to the Printer. Combined with the standard cassette and multifeder, a maximum of about 1,100 sheets of paper (64 g/m²) may be accommodated for continuous, large-volume printing work.

4. Power saving, toner saving design

The printer is designed to enter sleep mode (power saving mode) after remaining in standby mode for a specific period of time, thereupon automatically cutting the power to the fixing heater and ultimately limiting the total consumption of power.

The printer is also able to print in toner save mode, in which it prints using less toner (lighter output) to save on toner.

5. Auto interface switching mechanism

In addition to the parallel interface (Centronics compatible) and USB (V1.0 slave only) that come as standard, the printer allows the connection of a build-in print server (option; 10Base-T/100Base-TX). Depending on which interface board to use, the Printer will automatically switch among parallel, USB, and Ethernet (option) interfaces.

6. Auto emulation switching

This printer supports the Hewlett-Packard's PCL5e and PCL-XL printer language. Also, Adobe PostScript 3 can be provided by installing the optional Canon Adobe PostScript 3 Module A-65. This enables auto emulation switching for PCL and PostScript based on the received data.

II. SPECIFICATIONS

A. Printer

1. Printer engine

1) Type	Desktop page printer
2) Printing method	Electrophotostatic
3) Printing speed (Note 1)	20 pages/min (A4, horizontal), 11 pages/ min (A3)
4) First print time (Note 2)	11.0 sec (approx.; A4, horizontal)
5) Wait time (Note 3)	30 sec or less
6) Resolution	
Main scanning direction	600 dpi
Sub scanning direction	600 dpi
7) Image formation system	
Laser	Semiconductor laser
Scanning method	6-face mirror
Photosensitive drum	OPC (30-mm dia.)
Charging	Roller charging
Exposure	Laser scanning
Toner	Magnetic, 1-component, dry
Development	1-component toner projection
Toner supply	Cartridge replacement (EP-65; good for about 10,000 A4 pages, dot ratio at 4% and print ratio at 5%)
Transfer	Roller transfer
Separation	Curvature separation
Cleaning	Rubber blade
Fixing	Heat roller fixing
8) Pickup	Multifeeder tray Cassette Paper feeder (option)
Paper type	Plain paper, thick paper, colored paper, label sheet, recycled paper, transparency film, envelopes
Paper size	
Multifeeder tray	Plain paper (64 g/m ² to 90 g/m ² , recommended) or thick paper (91 g/m ² to 157 g/m ² , recommended) or label sheets of following dimensions: 76.2 (W) x 98 (L) to 297 (W) x 431.8 (L) mm
Cassette	Plain paper (64 g/m ² to 90 g/m ² , recommended) of following sizes: B3, B4, A4, A4R (vertical), B5, A5, 11 x 17, LGL, LTR, Executive; label sheets
Stack multifeeder	10 mm high (about 100 sheets of 64 g/m ² paper)
Cassette	25 mm deep (about 250 sheets of 64 g/m ² paper)
Cassette type	Universal cassette designed for following: A3, B4, A4, A4R (vertical), B5, A5, 11 x 17, LGL, LTR, Executive
9) Delivery	Face-down (250 sheets max. of 64 g/m ² paper)
10) Operating environment	
Temperature	7.5 to 32.5°C (45.5 to 90.5°F)
Humidity	5% to 90% RH
Atmospheric pressure	746 to 1013 hPa (560 to 760 mmHg)
11) Power consumption	Sleep mode: 16 W (avr)
(at 20°C room temp,	In standby: 118 W (avr)
at rated supply voltage)	In printing: 448 W (avr)
Maximum:	850 W or less

12) Noise (published noise by ISO9296)	Sound power level 67 dB or less (printing) 57 dB or less (standby) Sound pressure level 53 dB or less (printing) (bystander position) 38 dB or less (standby)
13) Dimensions	488 (W) x 455 (D) x 311 (H) mm/18.9 (W) x 17.7 (D) x 12.2 (H) in. (w/o options)
14) Weight	15 kg/33 lb (approx.; including 250-sheet cassette), 2 kg/4 lb (approx.; cartridge)
15) Power supply	120 to 127 V, 220 to 240 V 50/60 Hz
16) Options	Paper Feeder Unit PF-65 (3 units max.) Universal Cassette UC-65 Hard Disk HD-65 Ether Board EB-65

-
- Notes:**
1. Based on test prints made at 20°C room temperature with the rated supply voltage. May be longer depending on the type of paper and the fixing mode selected.
 2. Time required (room temperature at 20°C and printer in standby) from when the print signal arrives from the video controller to when a single A4 sheet is received and delivered to the delivery tray. May be longer depending on the type of paper and the fixing mode selected.
 3. At 20°C room temperature, without an expansion RAM.
-

The above specifications are subject to change for product improvements.
--

2. Video Controller

1) CPU	Power PC 405 (200 MHz)
2) Memory (RAM)	8 MB (built-in; may be expanded to 72 MB max. with option)
3) Memory (ROM)	8 MB (built-in; may be expanded to 16 MB max. with option)
4) RAM slot	1
5) ROM slot	3
6) Host interface	
Standard	<ul style="list-style-type: none"> • Centronics (IEEE1284 compatible) • USB (V1.0 slave only) • 10Base-T/100Base-TX
Option	
7) Translator	
Standard	PCL5e, PCL-XL
Option	Adobe PostScript Level 3 Module A-65
8) Resident font	45 scalable fonts (MicroType fonts), 32 TrueType fonts, 9 Bitmap fonts
9) Optional font	136 fonts for A-65 module
10) Scaler	UFST
11) Option	Flash ROM Module FR-65 (4MB: for fonts and macros storage)

The above specifications are subject to change for product improvements.
--

B. Options

1. Built-in print server

a. Hardware

- 1) Interface 10Base-T, 100Base-TX
- 2) CPU AXIS: EXTRAX100LX (32-bit RISC CPU 100 MHz)
- 3) ROM 2 MB
- 4) RAM 4 MB
- 5) Dimensions 100 (W) x 85.5 (D) x 24 (H) mm/3.9 (W) x 3.1 (D) x 0.8 (H) in.
- 6) Weight 100 g/0.2 lb (approx.)
- 7) Power supply 3.3 VDC (from printer)

b. Software

- 1) Protocol IPX/SPX, TCP/IP, AppleTalk (EtherTalk), NetBEUI/NetBIOS
- 2) Frame type IPX/SPX : 802.2, 802.3, Ethernet II, 802.2 Snap
TCP/IP : Ethernet II
AppleTalk : 802.2 SNAP (Phase II)
NetBEUI/NetBIOS : 802.2
- 5) Print application IPX/SPX : Bindery Server, NDS PServer, NPritner, RPrinter
TCP/IP : LPD, FTP, RAW, IPP
AppleTalk : CAP (Canon AppleTalk PrintServer)

The above specifications are subject to change for product improvements.

2. Paper feeder

- 1) Pickup paper size A3, B4, A4, A4R (vertical), B5, A5, 11 x 17, LGL, LTR, Executive (plain paper; 64 g/m² to 90 g/m², recommended)
- 2) Cassette size 25 mm deep (about 250 sheets of 64 g/m² paper)
- 3) Cassette type Universal (may be configured for following: A3, B4, A4, A4R (vertical), B5, A5, 11 x 17, LGL, LTR, Executive)
- 4) Dimensions 488 (W) x 406 (D) x 118 (H) mm/18.9 (W) x 15.7 (D) x 4.7 (H) in.
- 5) Weight 5 kg/11 lb (approx., including cassette)
- 6) Power supply 24 VDC, 5 VDC (from printer)

The above specifications are subject to change for product improvement.

3. Hard disk

- 1) Memory 10 GB
- 2) Interface ATA-3
- 3) Dimensions 112 (W) x 136 (D) x 28 (H) mm/4.3 (W) x 5.1 (D) x 1.1 (H) in.
- 4) Power supply 5 VDC (from printer)

The above specifications are subject to change for product improvements.

III. SAFETY

A. Safety of the Laser Unit

Although invisible, laser light is used inside the laser/scanner unit. Do not disassemble the laser/scanner unit, as exposure to laser light can damage your eyes.

The Printer's laser/scanner unit is not designed for adjustment in the field. The following shows the label attached to the cover of the laser/scanner unit.



Figure 1-3-1

B. Safety of Toner

Toner is a non-toxic material composed of plastic and small amounts of colorings. If your skin or clothes came into contact with toner, remove as much of it as possible using dry tissues; then, rinse with cold water. (Do not use warm water. The toner will turn into jelly, and will not come off.)

Do not bring toner into contact with vinyl material. They tend to react with each other.

C. Safety of Ozone

The Printer's charging roller generates a minute amount of ozone gas (O³) because of corona discharge (only when the Printer is in operation).

The Underwriters' Laboratory (UL) provides standards for amounts of ozone discharge, and the Printer is verified to satisfy the requirements at time of shipment from the factory.

IV. NAMES OF PARTS

A. External View

1. Printer engine

• Front of the printer

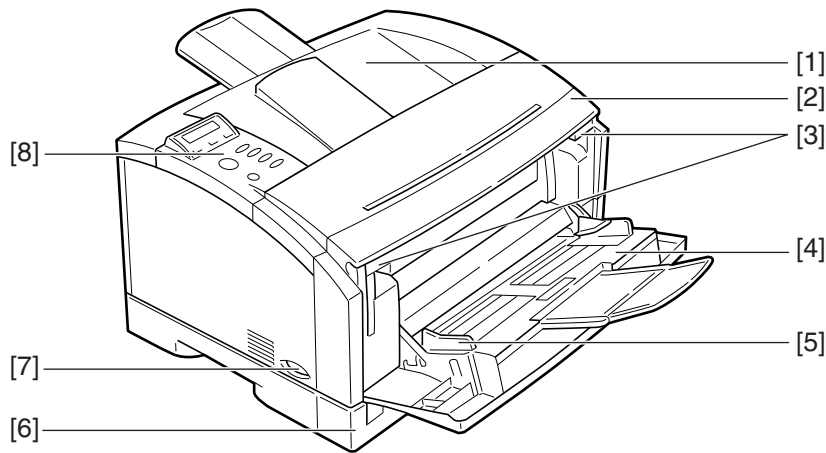

Figure 1-4-1

- 1: Delivery tray
- 2: Front cover
- 3: Open/close lever
- 4: Multifeeder tray

- 5: Paper guide
- 6: Cassette
- 7: Power supply switch
- 8: Control panel

• Rear of the printer

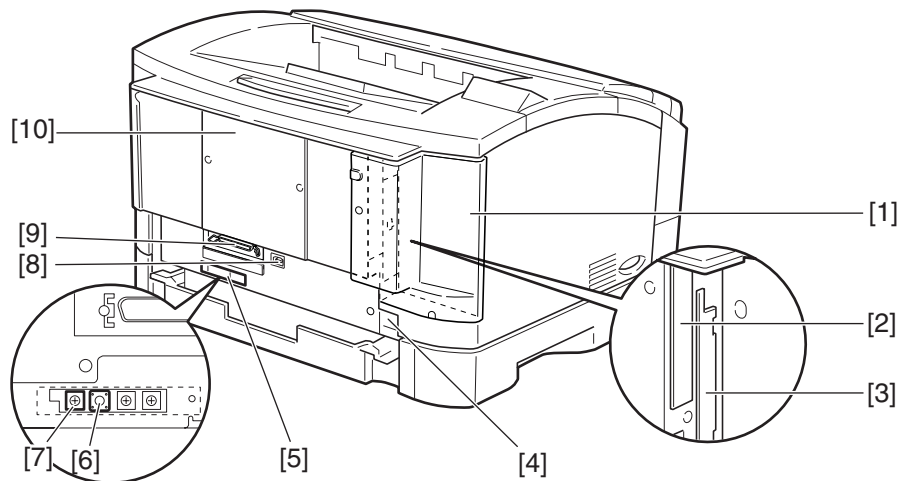

Figure 1-4-2

- 1: Expansion board slot cover
- 2: Expansion board slot 1
- 3: Expansion board slot 2
- 4: Power receptacle
- 5: Test Print switch

- 6: Test Print switch
- 7: Leading edge margin adjusting volume (VR101)
- 8: USB interface connector
- 9: Parallel interface connector
- 10: Slot cover

• Behind the front cover

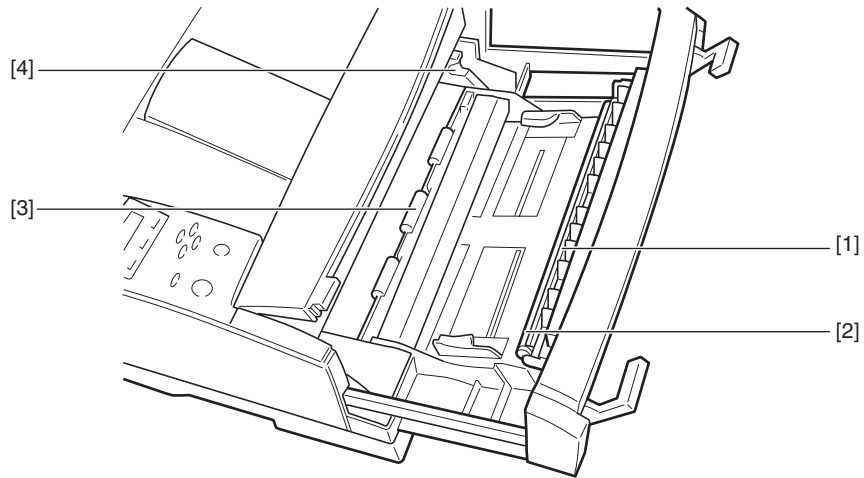

Figure 1-4-3

- 1: Static eliminating brush
- 2: Transfer charging roller

- 3: Toner cartridge guide
- 4: Registration roller

2. Paper feeder

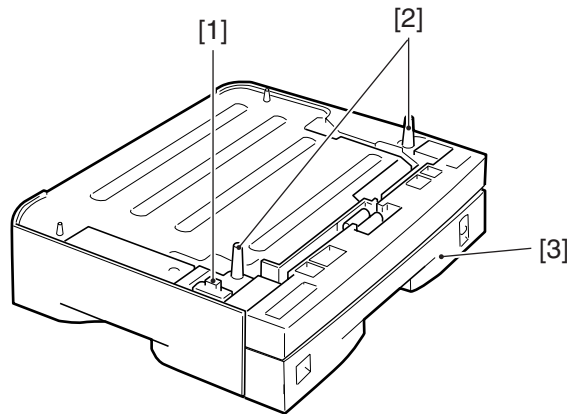

Figure 1-4-4

- 1: Connector
- 2: Positioning pin

- 3: Cassette

B. Cross Section
1. Printer engine

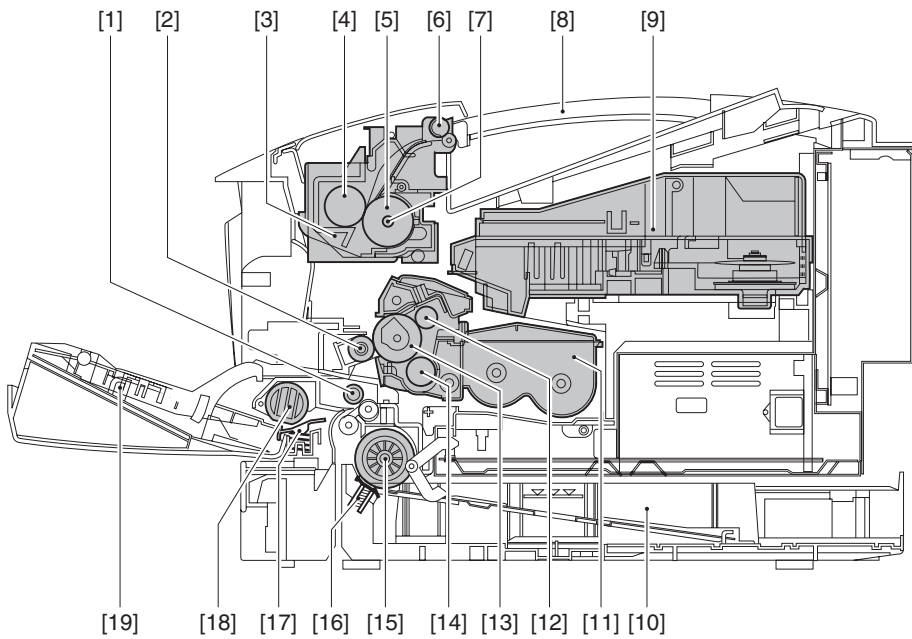

Figure 1-4-5

- | | |
|-----------------------------|--------------------------------|
| 1: Registration roller | 11: Cartridge |
| 2: Transfer charging roller | 12: Primary charging roller |
| 3: Fixing assembly | 13: Photosensitive drum |
| 4: Pressure roller | 14: Developing cylinder |
| 5: Fixing roller | 15: Cassette pickup roller |
| 6: Delivery roller | 16: Cassette separation pad |
| 7: Fixing heater | 17: Manual feed separation pad |
| 8: Control panel | 18: Manual feed pickup roller |
| 9: Laser/scanner unit | 19: Multifederer tray |
| 10: Cassette | |

2. Paper feeder

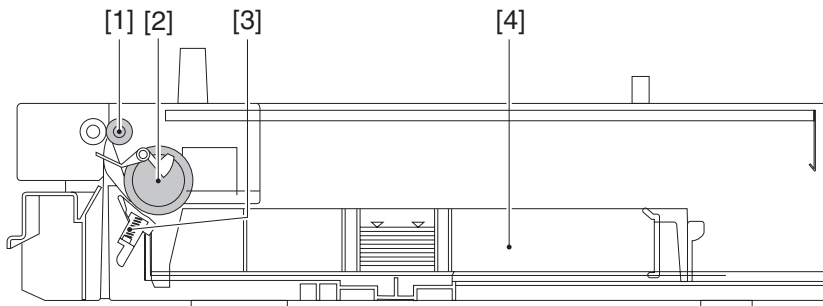

Figure 1-4-6

- | | |
|---------------------------|----------------------------|
| 1: Feeding roller | 3: Cassette separation pad |
| 2: Cassette pickup roller | 4: Cassette |

V. INSTALLATION

A. Points to Note About Installation

The Printer is thoroughly adjusted and inspected at the factory before it is packed and shipped. Installation work is important in that the Printer must perform in the field as it did when it passed the factory inspection.

The service engineer must have a full understanding of the machine, and install it in an appropriate site using specific steps, following up the work with a thorough inspection.

B. Selecting the Site

The site of installation must meet the following requirements; if possible, visit the site of installation before the Printer is delivered.

1. Power supply

The power supply must satisfy the following:

- AC: $\pm 10\%$ of ratings
- Frequency: 50/60 ± 2 Hz

2. Operating environment

The site must satisfy the following:

- Its floor must be level.
- Its temperature and humidity are as follows:
Ambient temperature: 7.5°C to 32.5°C (45.5 to 90.5°F)
Ambient humidity: 5% to 90% RH (There must not be condensation.)
- It must be well ventilated, without accumulation of heat.

Avoid the following areas:

- subject to direct rays of the sun; as necessary, provide thick curtains to block out the sun.
- subject to magnetism (magnet, magnetic field).
- subject to vibration.
- subject to dust.
- near a source of fire or water.

3. Spatial requirements

Allow an appropriate distance from all walls, thus ensuring unobstructed work space. (Figure 1-5-1) If the Printer is to be installed on a table, be sure that the table is wide enough to accommodate the Printer's feet (rubber pads) and strong enough to withstand the Printer's weight.

Dimensions Around the Printer (standard)

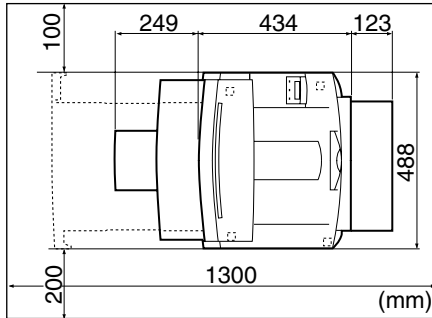

View from the Side (standard)

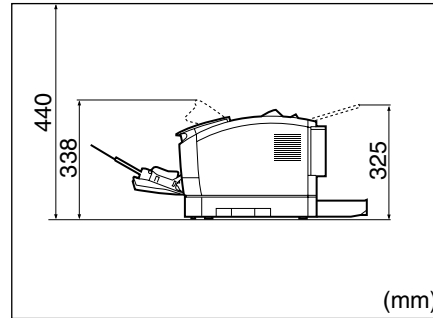

Locations of the Feet

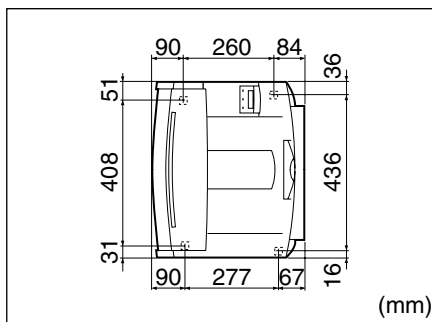

View from the side (with 3 paper feeders)

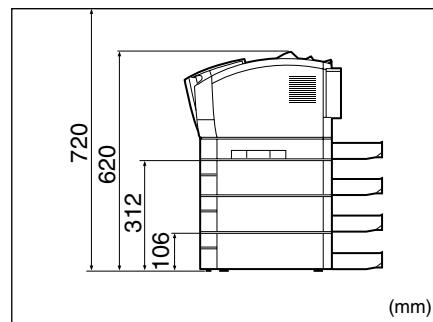

(Each rubber foot is 5 mm in height, and its tip is a square of 18 x 18 mm.)

Figure 1-5-1

C. Unpacking and Installing

When a piece of metal is brought in from a cold to warm place, droplets of water can develop on its surface. This phenomenon is known as condensation, and the use of an LBP suffering from condensation can cause various printing faults.

If the Printer has been brought in from a cold place, leave it alone for at least one hour before unpacking it.

1. Unpacking the printer

- 1) Unpack the Printer.
- 2) Check to make sure that none of the following is missing:
 1. power cord
 2. toner cartridge
 3. dust cover
 4. CD-ROM
 5. documentation
- 3) Remove the plastic bag used to cover the Printer, and check to make sure that the covers and the like are free of image and deformation from transportation.
- 4) Slide out the cassette, and move the Printer to the site of installation.
- 5) Place the Printer at the site of installation. (Take care.)
 - If the Printer is to be laid on a paper feeder, be sure that the position pins on the paper feeder fit into the openings in the Printer's bottom.
- 6) Remove the tape used to keep the parts in place.
- 7) Open the multif feeder tray, and pull the open/close lever to the front to slide out the front cover.
- 8) Remove the protective tape used to keep the transfer charging roller in place.
- 9) Lock the open/close lever, and close the front cover and the multif feeder tray.
- 10) Slide in the cassette.

2. Unpacking and installing the cartridge

- 1) Open the bag used to pack the cartridge, and take out the cartridge.
- 2) Holding the cartridge as shown in Figure 1-5-13, shake it gently up and down about 5 to 6 times so that the toner inside it will be even.
- 3) Place the cartridge on a level surface. While holding the top of the cartridge with one hand, pull the tab carefully with the other hand; then, pull straight out the sealing tape.
- 4) Open the multif feeder tray, and pull the open/close lever to the front to draw out the front cover.
- 5) Holding the cartridge with both hands, fit it in the Printer. At this time, be sure to slide in the cartridge carefully until it butts against the rear of the Printer.

3. Unpacking and installing the hard disk

Note: Before handling the hard disk, be sure to touch a metal area of the Printer to avoid damaging the PCBs by static charges.

- 1) Turn off the Printer, and disconnect the power cord and the interface cable.
- 2) Take out the hard disk from its packaging box.
- 3) Remove the vinyl bag used to cover the hard disk.
- 4) Remove the screw [1], and detach the expansion board slot cover [2].

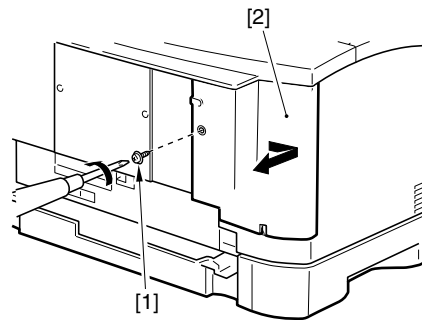

Figure 1-5-2

- 5) Remove the screw [3], and detach the expansion board slot 1 cover [4].

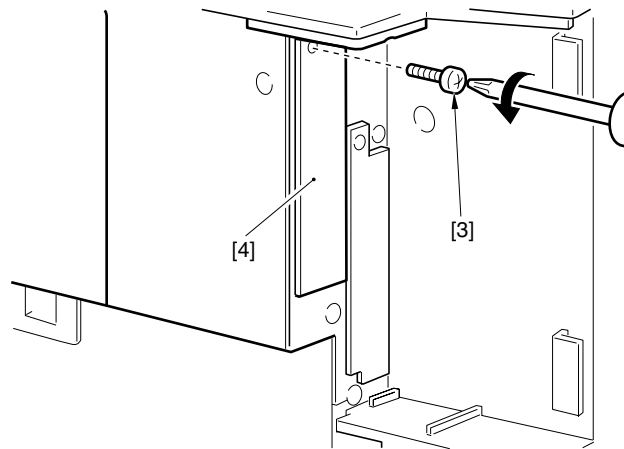

Figure 1-5-3

- 6) Holding the metal cover area [5] of the hard disk, slide in the hard disk along the guide rail.

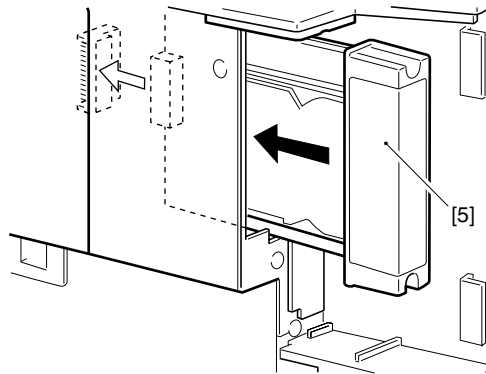

Figure 1-5-4

- 7) Secure the top and bottom of the hard disk with the 2 screws [6] that come with the hard disk.

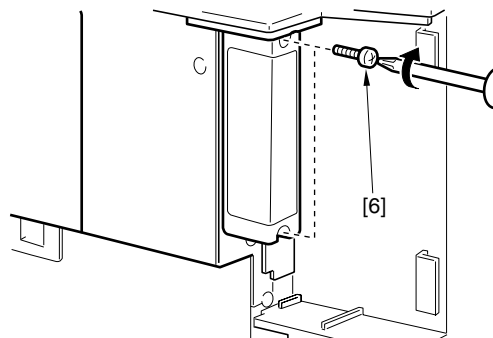

Figure 1-5-5

- 8) Attach the expansion board slot cover and the power cord.
9) Connect the Printer's power cord to the power outlet.

4. Unpacking and installing the built-in print server (Ether Board EB-65)

Caution: If possible, wear a wrist strap designed to prevent damage by static charges. The static charges in your body can damage the electric mechanisms when you install the built-in print server to the Printer.

Take particular care not to touch the parts in electric circuits.

- 1) Unpack the print server.
- 2) Take out the print sever from its packaging box.
- 3) Remove the vinyl bag used to cover the print server.
- 4) Remove the screw [1], and detach the expansion board slot cover [2].

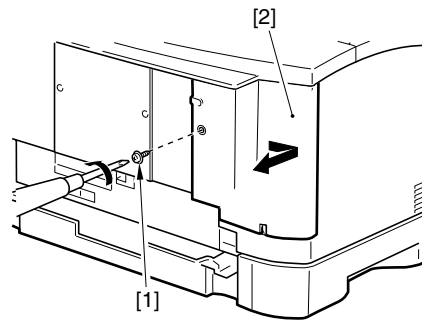

Figure 1-5-6

- 5) Remove the screw [3], and detach the expansion board slot 2 cover [4].

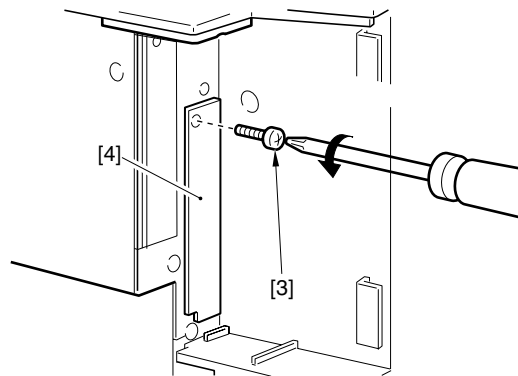

Figure 1-5-7

- 6) Slide in the print sever [5] into the expansion board slot 2 along the groove found inside.

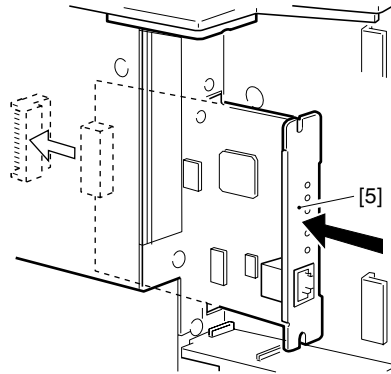

Figure 1-5-8

- 7) Secure the top and bottom of the print server using the two screws [6] that come with the print server.

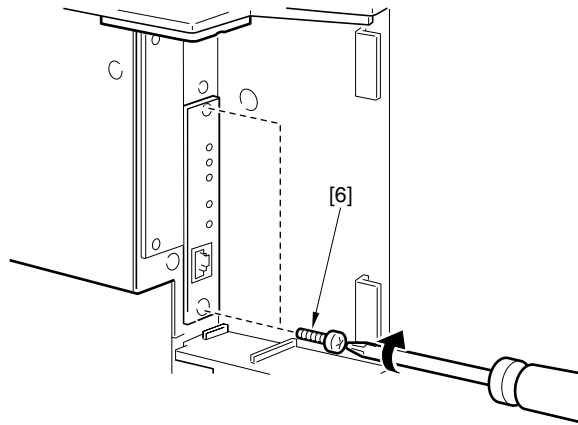

Figure 1-5-9

- 8) Connect the network cable to the connector of the print server to suit the network environment.

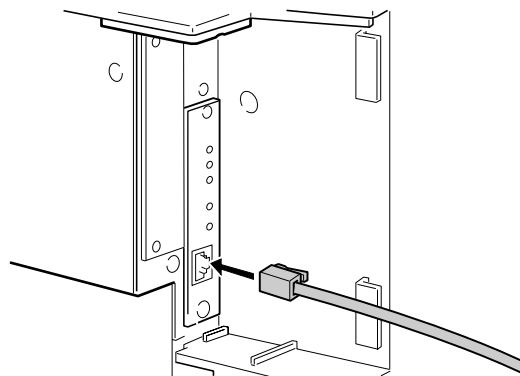

Figure 1-5-10

- 9) Connect the power cord.
10) Connect the Printer's power cord to the power outlet.

- 11) Turn on the power switch, and check to make sure that the LNK lamp (green) of the print server is ON.
 - In the case of 10Base-T, check to make sure that the LNK lamp is ON.
 - In the case of 100Base-T, check to make sure that the LNK lamp and the 100 lamp are ON.

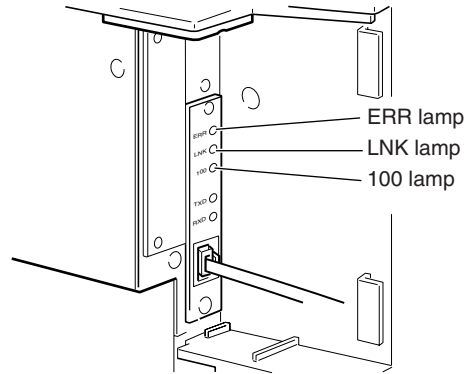

Figure 1-5-11

- 12) Turn on the power switch.
- 13) Thread the LAN cable through the groove in the expansion board slot cover, and secure the expansion board slot cover with a screw.

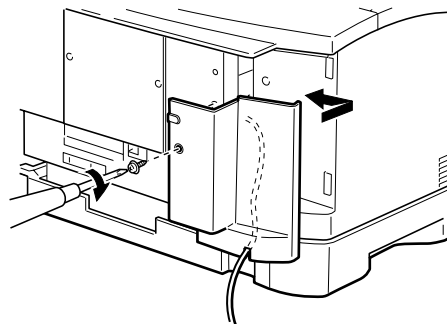

Figure 1-5-12

5. Checking the operation

- 1) Put paper in the cassette.
- 2) Connect the grounding wire to the Printer.
- 3) Connect the power cord to the Printer and the power outlet, and turn on the power switch. Be sure that the power cord is one designed for the Printer.
- 4) When the Printer is in standby state, press the Go key so that it enters off-line state.
- 5) Press the Menu key once, and press the Item key until the status indicator panel indicates 'TEST PRINT'.
- 6) Press the Enter key to execute 'TEST PRINT'. Check the test print for faulty images. If an option has been installed, check to make sure that its presence is indicated.
- 7) Clean up the area around the Printer, and set the Printer ready for use.

6. Points to note when using the printer

1. When turning on the power switches, be sure to start with the external devices and then the Printer. To turn off the power switches, be sure to start with the Printer and then the external devices. If you turn on/off an external device while the printer is ON, noise can be introduced to the Printer through the cable connecting the device and the Printer, causing an error in the Printer.
2. Whenever connecting the Printer with an external device, be sure to turn off the power switches of both and disconnect the power cords from the outlets. A fault can occur if the connector is connected or disconnected while the power switch is ON.
3. Be sure to turn off the power switch of the Printer before installing or removing the following: flash memory (option), Adobe PostScript Level 3 Module (option), expansion RAM DIMM (option), hard disk (option), built-in print server (option).
4. Be sure to use a shielded cable when connecting the Printer's parallel interface connector and an external device. Moreover, make sure that the parallel interface cable is no longer than 3 m.
5. Be sure to use a twisted-pair LAN cable of Category 3 or higher when connecting the Printer's 10Base-T/100Base-TX port and an external device to a 10Base-T network environment.
6. Be sure to use a twisted-pair LAN cable of Category 5 when connecting the Printer's 10Base-T/100Base-TX port and an external device to a 100Base-TX network environment.
7. Be sure not to touch the metal area of the connector before connecting or disconnecting the USB cable while the power switch is ON.
8. Be sure to use SHUT DOWN MENU to shut down the printer if the optional Hard Disk HD-65 has been installed.

D. When Storing or Handling the EP-65 Cartridge

The cartridge is subject to the effects of the environment it is in whether it remains packaged or installed in the Printer, and it takes on changes over time regardless of how many pages it has printed. The rate of change depends on the site of installation or storage, requiring full care when handling and storing it.

a. Before taking out of the package (removing the signal)

When storing the cartridge in a warehouse or a workshop, be sure that the environment meets the requirements in Table 1-5-1; in addition,

1. Avoid direct rays of the sun.
2. Avoid a place subject to vibration.
3. Avoid shocks as by hitting or dropping it.

Table 1-5-1 Temperature/Humidity Requirements for Storage

Temperature	Normal (9/10 of total storage period)		0 to 35°C
	Severe (1/10 of total storage period)	High	35 to 40°C
		Low	-20 to 0°C
Change in temperature (within about 3 min)			40°C→15°C -20°C→25°C
Humidity	Normal (9/10 of total storage period)		35 to 85%RH
	Severe (1/10 of total storage period)	High	85 to 95% RH
		Low	10 to 35% RH
Atmospheric pressure			345 to 1013 hPa (460 to 760 mmHg)
Total storage period			2.5 yr

Note: The total storage period refers to the period from the date of manufacture indicated on the cartridge package.

b. After taking out of the package (removing the seal)

The photosensitive drum is made of photoconducting material (OPC), and tends to deteriorate when exposed to strong light. The toner is also kept inside the cartridge, requiring care after the cartridge has been taken out its the package. Advise the user to take full care when handling/storing the cartridge.

1. Storing the cartridge after taking out of the package (removing the seal)

1. Be sure to keep it in a protective bag.
2. Avoid areas exposed to direct rays of the sun or near windows. Do not leave it in side a car for a long time, as the rise in temperature can be extreme.
3. Avoid areas subject to high/low temperature/humidity or areas subject to extreme changes in temperature or humidity.
4. Avoid areas subject to corrosive gases (e.g., insecticide) or areas subject to briny air.
5. Make sure that the temperature is between 0°C and 35°C.
6. Avoid CRT displays, disk drives, or floppy disks.
7. Keep it out of reach of children.

2. Effective period

The cartridge is verified to remain good for 2.5 years after the date of manufacture, indicated on its body using an abbreviated notation. For the user, the period is indicated on the package and the packing boxes (year, month; 2.5 years after the date of manufacture).

The use of a cartridge after the date indicated may not bring about expected print quality, making it desirable to use it up before the date indicated.

c. Points to note when handling

1. When fitting a new cartridge, or if some areas of the output image show white spots because of an uneven level of the toner inside the cartridge, hold the cartridge as shown, and shake it carefully to the left and right [1] about 5 to 6 times then up and down [2] about 5 to 6 times to even out the toner.

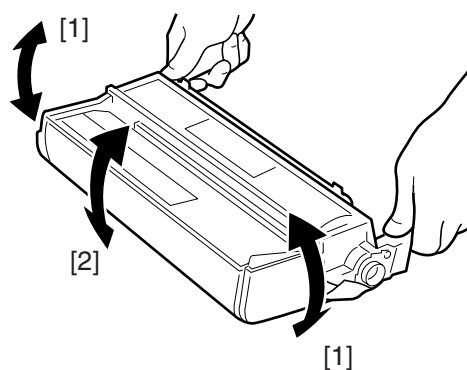

Figure 1-5-13

2. When transporting the Printer after taking out the cartridge from it, be sure to secure the transfer charging roller in place for protection. Keep the cartridge in a protective bag to avoid light. (See VI. 'Relocating the Printer.')
3. Do not place the cartridge near a CRT display, disk drive, or floppy disk. The magnetism from the cartridge can damage the data.
4. The photosensitive drum is vulnerable to strong light. Avoid subjecting it to direct rays of the sun or light 1500 lux or higher in strength. When exposed, it can produce images with white spots or black bands. (If they occur, leave the machine alone for a while to correct the faults. If the exposure is long, however, white spots or black bands may continue.)

5. Do not attempt to touch the surface of the photosensitive drum of the cartridge. Further, do not clean the photosensitive drum.

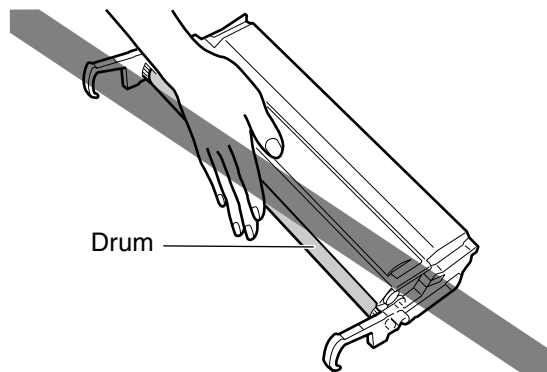

Figure 1-5-14

6. Do not place the cartridge upright or turn it over. Be sure it is laid with the label surface facing upward.
7. Do not disassemble the cartridge.

Reference: If the photosensitive drum is exposed to light of 1500 lux (general lighting) for 5 min and then left alone in the dark for 5 min, the faults can be corrected to a level satisfactory to practical uses. It is nevertheless important to avoid direct rays of the sun, which is about 10000 to 30000 lux in intensity.

VI. RELOCATING THE PRINTER

If the Printer must be relocated after installation by truck or other means of transportation, take note of the following:

1. Moving the printer with the cartridge removed

Once the cartridge is removed, the transfer charging roller can become displaced. Secure the transfer charging roller in place using tape as follows before starting to move the Printer:

- If shipping tape is used, be sure to attach it so that the tape protection is over the gears and the bushings, thus protecting the gears and the bushings of the transfer charging roller from adhesive.
- If common tape is to be used, be sure to put a protective material (e.g., lint-free paper) between the tape and the gears/bushings, thus protecting the gears and the bushings of the transfer charging roller from adhesive.

Note: If the adhesive of the tape came into contact with a gear or a bushing, be sure to clean it before using it.

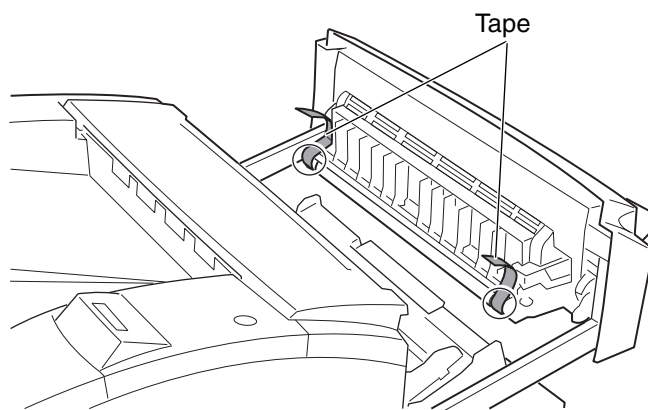

Figure 1-6-1

VII. ROUTINE MAINTENANCE/INSPECTION BY THE USER

To ensure that the Printer remains in its best condition, advise the user to provide the following maintenance:

1. Cartridge

If the images are fuzzy or show white spots, or the cartridge is running out of toner, shake or replace the cartridge.

2. Cassette pickup poller/cassette separation pad

If pickup faults tend to occur, wipe the pickup roller/separation pad with a cloth moistened with water, and then dry wipe it. If the faults still occur, replace both cassette pickup roller and cassette separation pad at the same time (at about 80,000th page; see Chapter 3 IV-A-1/2 “Replacing the Cassette Pickup Roller” and “Replacing the Cassette Separation Pad.”)

3. Fixing roller

If the back or face of printed sheets have black dots, clean the fixing roller as follows:

- 1) Prepare an A4 or LTR sheet of paper for printing.
- 2) Press the Go key so that the Printer enters off-line state.
- 3) Press the Menu key until the status indicator panel indicates ‘TEST MENU’.
- 4) Press the Item key until the status indicator panel indicates ‘TEST MENU CLEANING PAGE’.
Then, press the Enter key so that a cleaning sheet (Figure 1-7-1) will be printed.

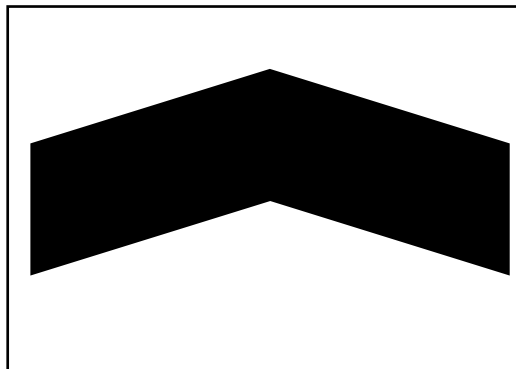

Figure 1-7-1

- 5) Press the Go key so that the Printer enters on-line state, then press the Menu key.
- 6) Open the multif feeder tray, and place the cleaning sheet generated in step 2) with its arrow side facing upward and the arrow pointing at the rear of the Printer.

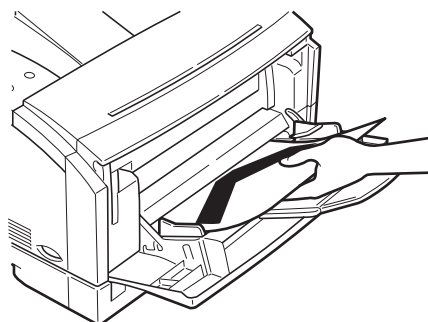

Figure 1-7-2

- 7) Press the Go key so that the Printer starts cleaning the fixing roller.

Note: Allow about 5 min before the cleaning sheet is delivered to the delivery tray after cleaning is started.

- 8) Press Go key to bring the printer on-line state.

4. Manual feed pickup roller

If pickup faults start to occur often because of glue or lint from recycled paper, advise the user to purchase the following for cleaning the pickup roller; if faults still occur after cleaning, the manual feed pickup roller and the manual feed separation pad must be replaced at the same time (about 50,000 pages).

- 1) Obtain a manual feed tray cleaning tool and a cleaning sponge.

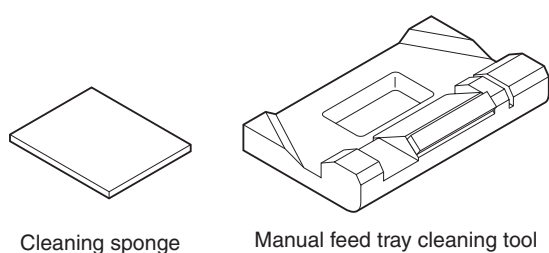

Figure 1-7-3

- 2) Peel the sticker from the cleaning sponge, and attach it as shown to the manual feed cleaning tool.

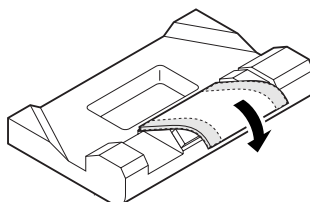

Figure 1-7-4

- 3) Moisten the sponge portion of the manual feed tray cleaning tool with water.

Note: Be sure the sponge is no more than moist. If water shows when the sponge portion is touched, shake it well to rid it of water.

- 4) Open the manual feed tray; while pushing down the holding plate, fit the manual feed cleaning tool in place as shown.

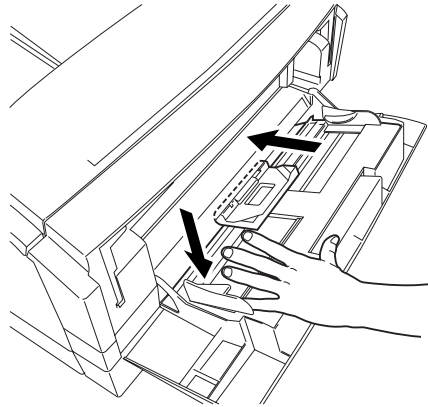

Figure 1-7-5

- 5) Set the paper guide of the multifeeper manual feed tray to postcard size.

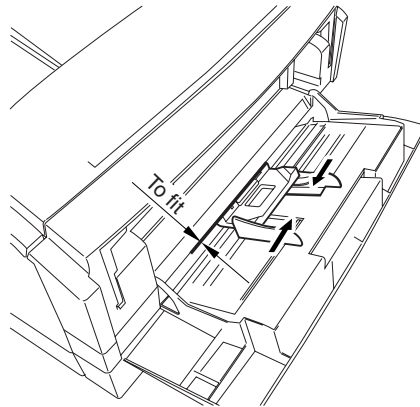

Figure 1-7-6

Note: After fitting the manual feed tray cleaning tool in place, check to make sure that it has been pushed so that the edge of the pickup guide and the step of the manual feed tray cleaning tool match. Otherwise, the dirt of the manual feed pickup roller cannot be removed.

- 5) Press the Go key so that the Printer enters off-line state.
- 6) Press the Menu key until the status indicator panel indicates 'TEST MENU'.
- 7) Press the Item key until the status indicator panel indicates 'CLEANING ROLLER'. Then, press the Enter key so that the Printer starts to clean the roller.

Note:

1. Check to make sure that no paper exists in the multifeeper tray before executing 'CLEANING ROLLER'. Otherwise, the paper will be picked up, causing a jam.
2. Be sure to detach the cleaning tool after cleaning the manual feed pick up roller.
3. Allow about 10 sec between the start and the end of cleaning.
4. After using it for thee cleaning sessions, or if its surface has become excessively soiled, replace it with a new cleaning sponge.

- 7) Open the paper guide, and detach the cleaning tool while pushing down the Holding plate.
- 8) Press the Go key so the Printer enters on-line state.

VIII. USING THE PRINTER

A. The Operation Panel

The operation panel is used to perform basic printer operations, make printer configuration changes that software applications cannot control, identify available typefaces, and check the status of the printer.

The operation panel consists of the status indication display, four indicator lights, and six menu and operation keys.

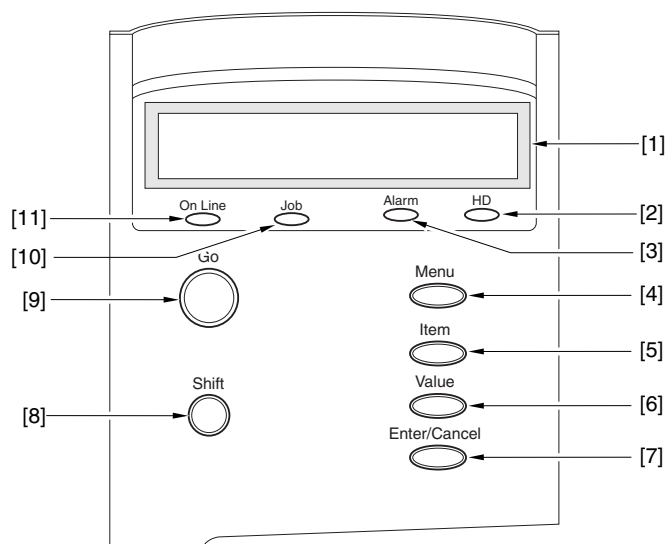

Figure 1-8-1

[1] Status indication display (2-line, 16-segment LCD)

Indicates the printer status and menu setting, and displays messages.

[2] Hard Disk access indicator

Blinking: The hard disk is being accessed.

OFF: The hard disk is not being accessed.

[3] Alarm indicator

ON: An error has occurred and printing has stopped.

OFF: Operation in normal and there is no error.

[4] Menu key

With the printer off-line, press the Menu key to scroll through the menu names and return to the first menu name. To scroll back through the menu names in the opposite direction, press the Shift and Menu keys.

Depending on what options have been installed, some menu names may not appear.

[5] Item key

With a menu name displayed, press the Item key to scroll through all the items on the menu and return to the first item. To scroll back through the items in the opposite direction, press the Shift and Item keys.

Depending on what options have been installed, some menu names may not appear.

[6] Value key:

With an item name displayed, press Value key to step through the item's values. Press Shift and Value keys to step through the values in reverse order. Some items have a large range of numbers from which to choose a value.

[7] Enter/Cancel key

Save a value you selected for an item in the menu. An asterisk (*) marks the value designated as the current default.

[8] Shift key

Press the Shift and another keys to access the alternate function. Allows you to execute the alternate function of dual function keys. The two functions on the dual function keys are separated by a slash in the key name on the operation panel.

[9] Go

Takes the printer off-line and back on-line. When the On Line indicator is on, the printer is ready to receive data and print. When the On Line indicator is off, the printer is off-line and the other keys on the operation panel can be used to view and change settings.

Resumes printing after the printer display a message and stops printing. For most situations, after you press Go key, the message clears and printing resumes.

[10] Job indicator

ON:A page buffer has been composed and is currently stored in printer memory.

OFF:There is no data stored in printer memory.

[11] On Line indicator

ON:The printer is on-line.

Blinking:The printer is processing a print job.

OFF:The printer is off-line.

Depending on what options you have installed, some items may not appear.

B. Operation Panel Menus

You can access the following menus through the operation panel:

- SHUTDOWN MENU*3
- SECURED JOB MENU*1
- TEST MENU
- PCL MENU
- PS MENU*2
- FEEDER MENU
- CONFIG MENU
- JOB CONTRL MENU*3
- PARALLEL MENU
- USB MENU
- ETHERNET MENU*4
- LANGUAGE MENU
- RESET MENU
- JOB LOG MENU

NOTE: *1.If there is no secured job,this is not displayed.

*2.This is not displayed,when the option Adobe Postscript 3 Module is not installed.

*3.This is not displayed,when the option Hard Disk is not installed.

*4.This is not displayed,when the option print server is not installed.

Follow these steps to access the menus and make selections:

1. Accessing and selecting menu items

- 1) Check the operation panel and be sure the Job indicator is OFF.
- 2) Press the Go key to set the printer off-line. The On Line indicator goes OFF and PAUSED is displayed in the top line.
- 3) Press the Menu key to display the name of the first menu. Press the Menu key until you see the menu.
- 4) Press the Item key to display the name of the first item on the menu. Press the Item key until you see the item.
- 5) Press the Value key until you display the values you want to change.
- 6) If you want to change the setting, press the Value key until the value you want is displayed. Then press the Enter key.
- 7) Press the Go key to set the printer on-line.

Figure 1-8-2 lists the User Menu Operation Flow.

2. Confirming menu selections

- Here are two ways the selections made through the operation panel can be reviewed:

Scroll through the menu items to check all selections marked with an asterisk.

Make a Test Print. The printed output lists all settings that are in effect. See the Printing the Test Print section for more information.

3. Restoring the default settings

Types of default settings are as follows:

Factory default settings are those set for each menu item at the factory. The printer uses these settings changed.

Temporary default settings are those set by the application software for the current print job.

Permanent default settings are those set through the operation panel. These selections remain in effect even when the printer is turned OFF, or send a different request through the application.

4. Resetting the default values

This resets various settings to their default values.

MENU: Resets most menu items to their default values.

FONTs: Clears memory of all fonts.

FORMS: Clears memory of all forms

STORED JOB: Clears memory of all stored jobs.

JOB LOG: Clears the job log.

ERR LOG: Clears the error log.

JAM LOG: Clears the jam log.

5. Shut down

This menu is used to shut down the printer. You should always use this menu to shut down the printer if the optional Hard Disk HD-65 has been installed.

C. Service Menu

The Service Menu is a hidden menu and contains the following sub menus:

1. ERR/JAM LOG MENU (Print of Error/Jam log Report)
2. FORMAT MENU (Format of Hard disk drive and Flash ROM)
3. NVRAM MENU (Display of counter and copying the counter readings)
4. PASSWORD MENU (Clear of administrator password)
5. ENGINE MENU (Clear of fuser error 'E000, E001, E003, E808')

The Service Menu is entered at power up by a sequence of two key presses. Each key press is a combination of 2 keys.

1. Press the 'Go' and 'Menu' key together and hold until the LCD displays WARMING UP.
2. Press the 'Menu', 'Value' and 'Enter' keys together and hold until 'SERVICE MENU' is displayed, which should take about 1 second.

The service menu will become operational when the LCD changes to SERVICE MENU.

Figure 1-8-3 lists the Service Menu Operation Flow.

User Menu Operation Flow

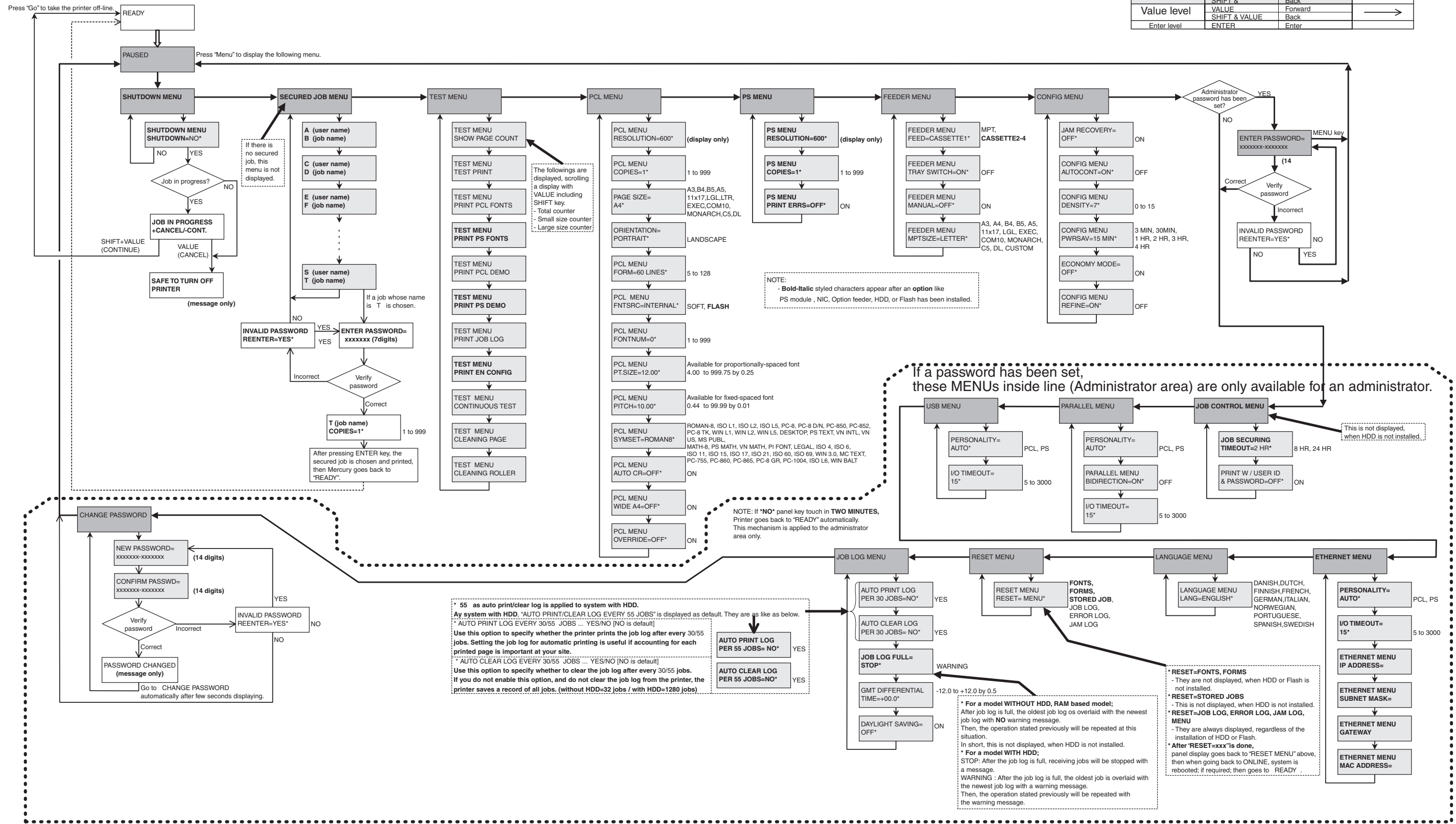

Figure 1-8-2

Service Menu Operation Flow

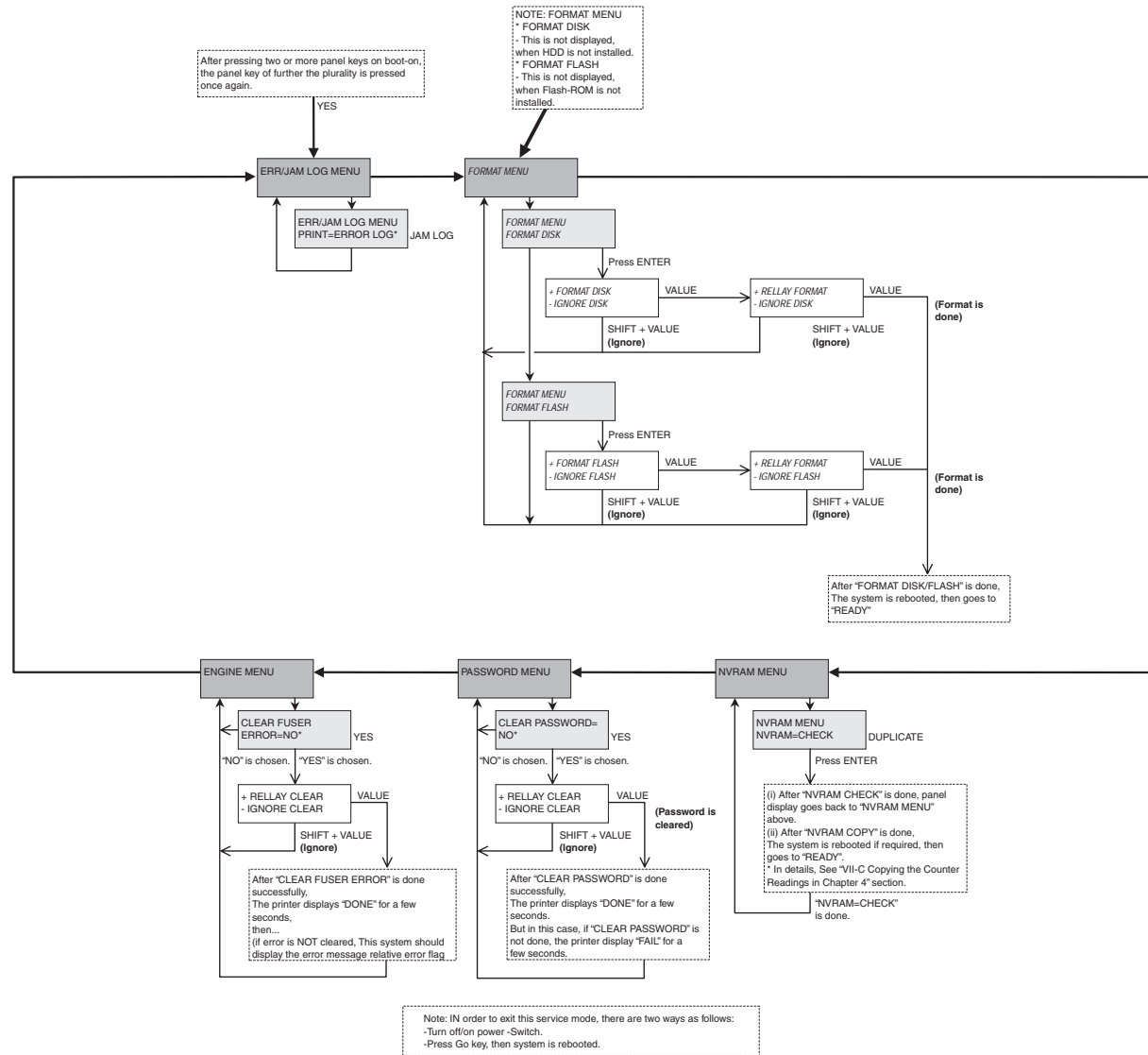





Figure 1-8-3

CHAPTER 2

OUTLINE OF OPERATION

1. The roles played by specific functions, the relationship between electrical system and mechanical system, and the timing at which each mechanism is driven are discussed according to functions.

In any diagram, the symbol  indicates a mechanical path. If a signal name is given together with the symbol , the flow of a single electric signal is indicated, while the symbol  indicates the flow of multiple electric signals.

2. In any digital circuit, the level of an electric signal is indicated as follows: if high, using the letter H or without a slash (/); if low, using the letter L or with a slash (e.g., /SCNON).

If a signal is shown as being H or without a slash, the signal is true (generated) in the presence of a supply voltage level; it is false (not generated) in the absence of a voltage (i.e., GND level). The opposite is true of a signal shown as being L or preceded by a slash.

The Printer uses a microprocessor, but its mechanisms are omitted from discussions, as they cannot be checked in the field.

In addition, PCBs are not to be repaired in the field, and explanations of circuitry are limited to outlines using block diagrams. Explanations may cover either from sensors to inputs of major PCBs or from outputs of major PCBs to loads; or, they are limited to block diagrams prepared according to functions.

I. BASIC OPERATION	2-1	V. PICKUP/FEEDING SYSTEM	2-46
II. ENGINE CONTROL SYSTEM	2-7	VI. VIDEO CONTROL SYSTEM	2-59
III. LASER/SCANNER SYSTEM	2-30	VII. PAPER FEEDER	2-65
IV. IMAGE FORMATION SYSTEM	2-37		

I. BASIC OPERATION

A. Functional Construction

The Printer may be broadly divided into five functional blocks: engine control system, laser exposure system, image formation system, pickup/feeding system, and system control system.

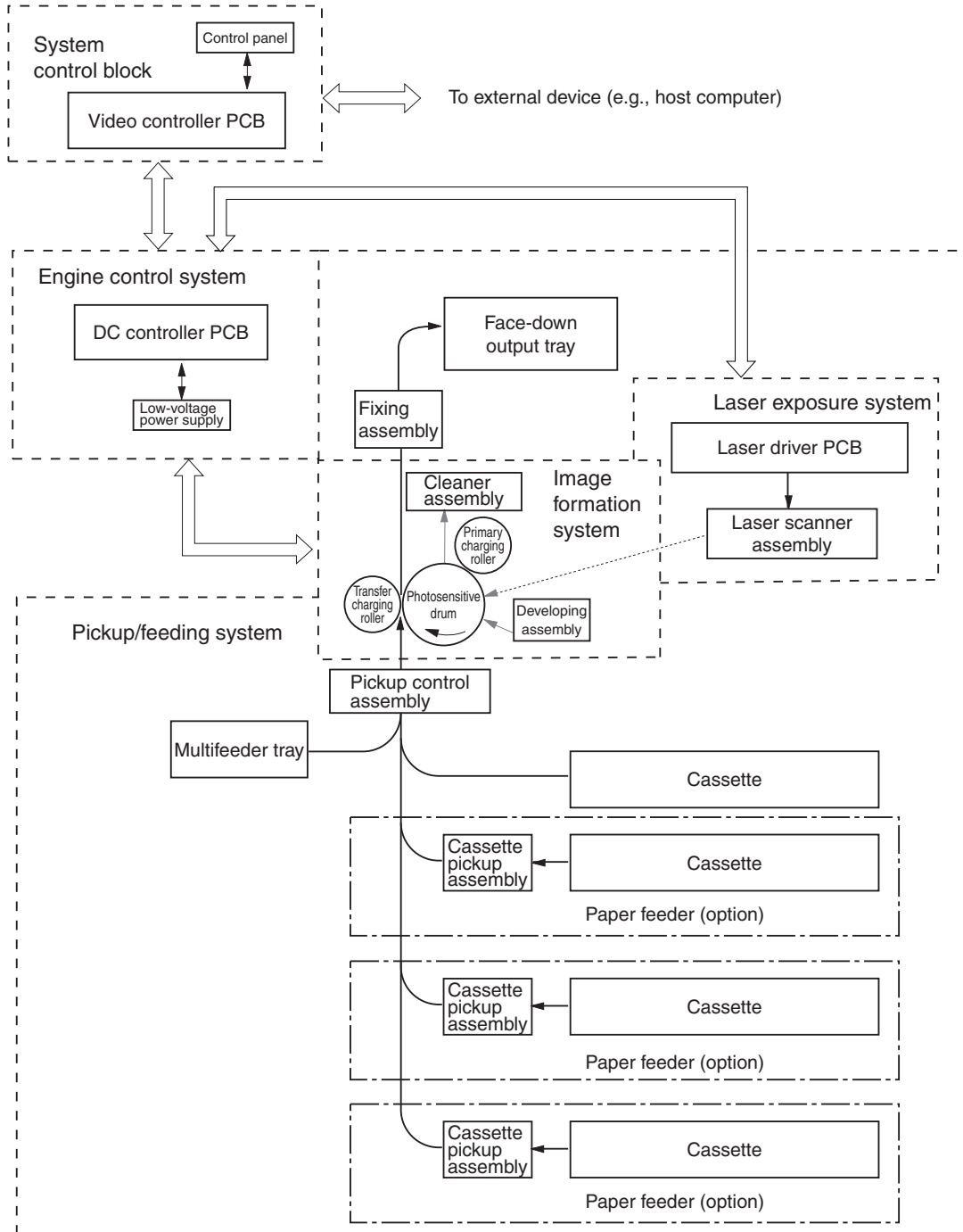

Figure 2-1-1

B. Sequence of Basic Operation

The sequence of the printer operation is controlled by the microprocessor found on the DC controller PCB. The conditions and the purposes of the sequence of each interval at power-on and during printing are as follows:

- **At Power-On**

Table 2-1-1

Interval		Purpose	Remarks
wait	WMUP (warm-up)	From when the power switch is turned on to when the surface temperature of the fixing roller reaches 140°C.	To heat the fixing roller and to put the Printer to warm-up rotation state.
	WMUPR (warm-up rotation)	From when warm-up ends to when the main motor is turned on and then off.	To make the surface temperature of the fixing roller even. Also, to rid the drum surface of potential and to clean the transfer charging roller.
STBY (standby)		From when the warm-up interval ends to when the /PRNT signal arrives from the video controller. Or, from when LSTR ends to when the /PRNT signal arrives from the video controller or the power switch is turned off.	To control the fixing roller to standby state, thereby keeping the Printer ready for printing. After the power switch is turned on, the Printer moves to standby state for the following conditions to reduce wait time: <ul style="list-style-type: none"> • 25 sec or more passes and, in addition, the temperature of the fixing assembly is 150°C or higher. • 27 sec or more passes and, in addition, the temperature of the fixing assembly is 145°C or higher.

• Basic Sequence of Operation at Power-On

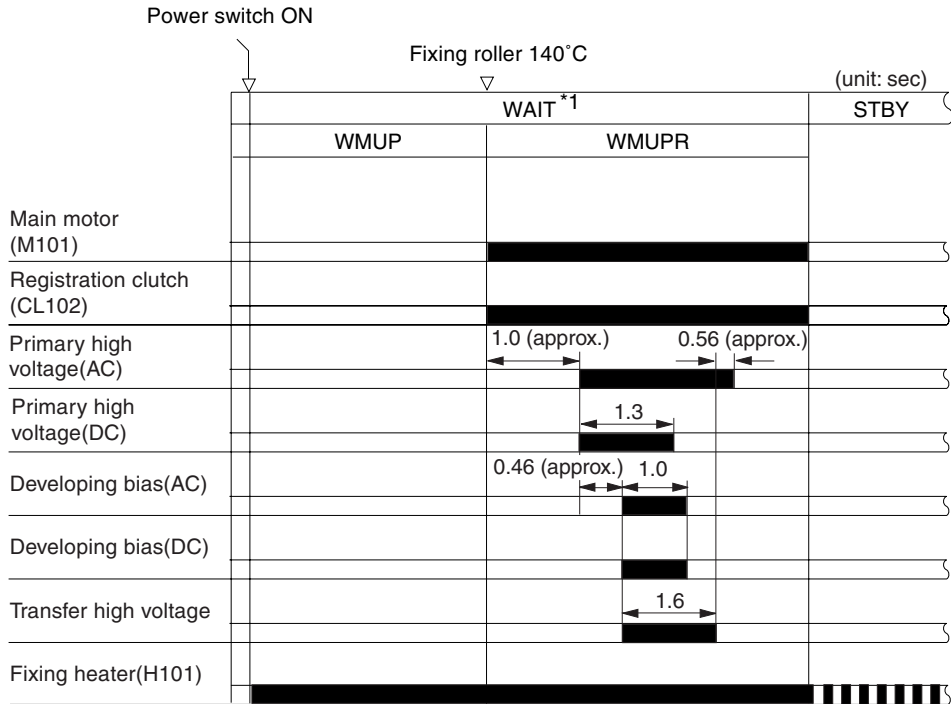

*1: WAIT End Conditions

25 sec or more passes after the start of supplying the fixing assembly with power and, in addition, the temperature of the fixing assembly is 150°C or higher.
 27 sec or more passes after the start of supplying the fixing assembly with power and, in addition, the temperature of the fixing assembly is 145°C or higher.

Figure 2-1-2

- **During Printing**

Table 2-1-2

	Interval	Purpose	Remarks
STBY (standby)	From when the warm-up rotation interval ends to when the /PRNT signal arrives from the video controller. Or, from when LSTR ends to when the /PRNT signal arrives from the video controller or when the power switch is turned off.	To control the fixing roller to standby state, thereby keeping the Printer ready for printing.	
INTR (initial rotation)	From when the /PRNT signal arrives from the video controller to when the DC controller generates the /TOP signal.	To make the sensitivity of the photosensitive drum stable by way of preparing for printing.	
print	From when the primary DC bias goes off to when the main motor stops.	To form an image on the photosensitive drum according to the /VDO signal and VDO signal from the video controller and then to transfer the toner image to paper.	
LSTR (last rotation)	From when the primary DC bias goes off to when the main motor stops.	To deliver the last sheet of paper. In addition, to rid the drum surface of potential and to clean the transfer charging roller.	The Printer enters the initial rotation interval as soon as the /PRNT signal arrives from the video controller.

• Basic Sequence of Operation During Printing (from printer cassette, A4)

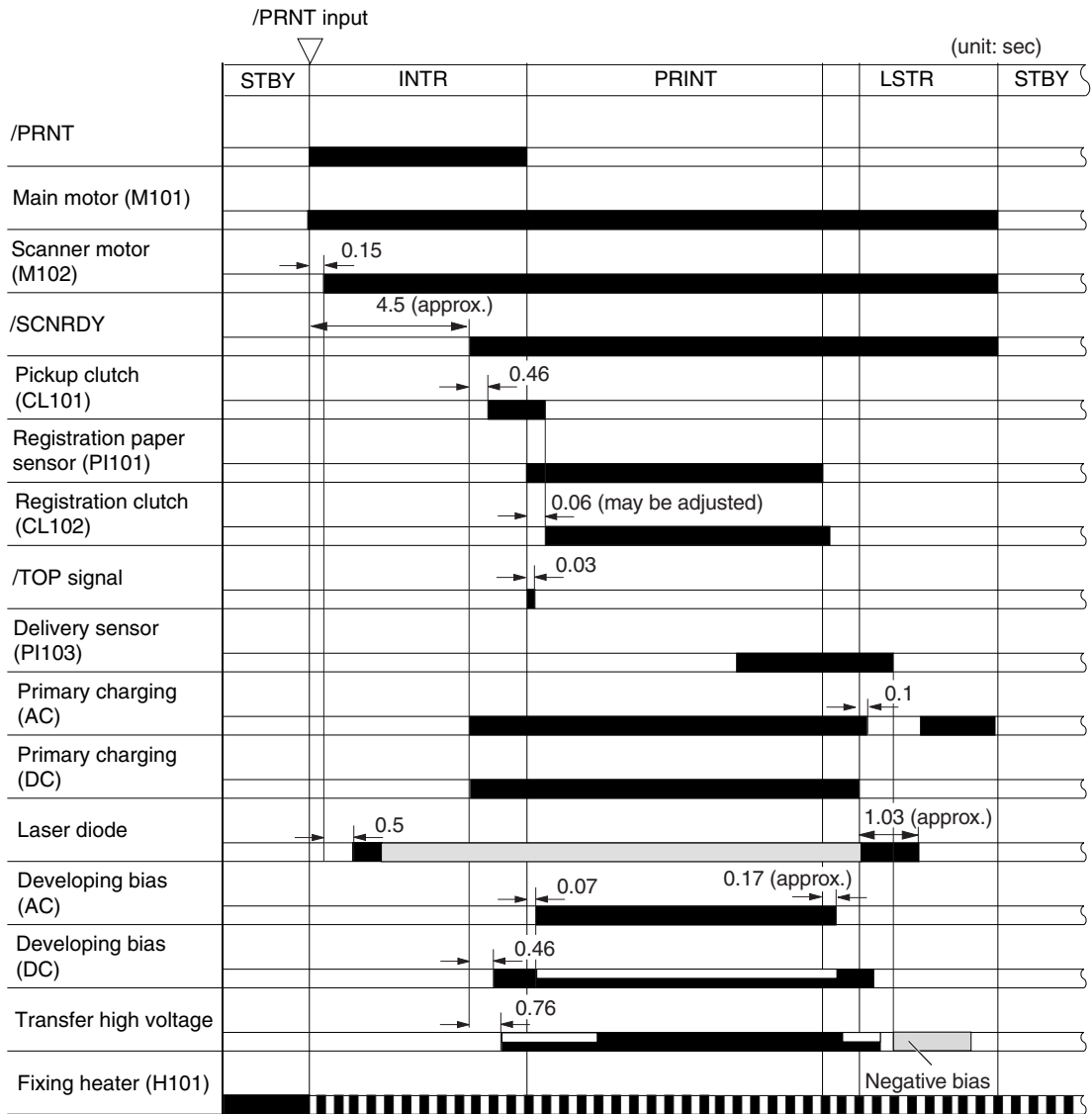

Figure 2-1-3

C. Power-On Sequence

The following shows the flow of operation from when the power switch is turned on to when the Printer enters warm-up state.

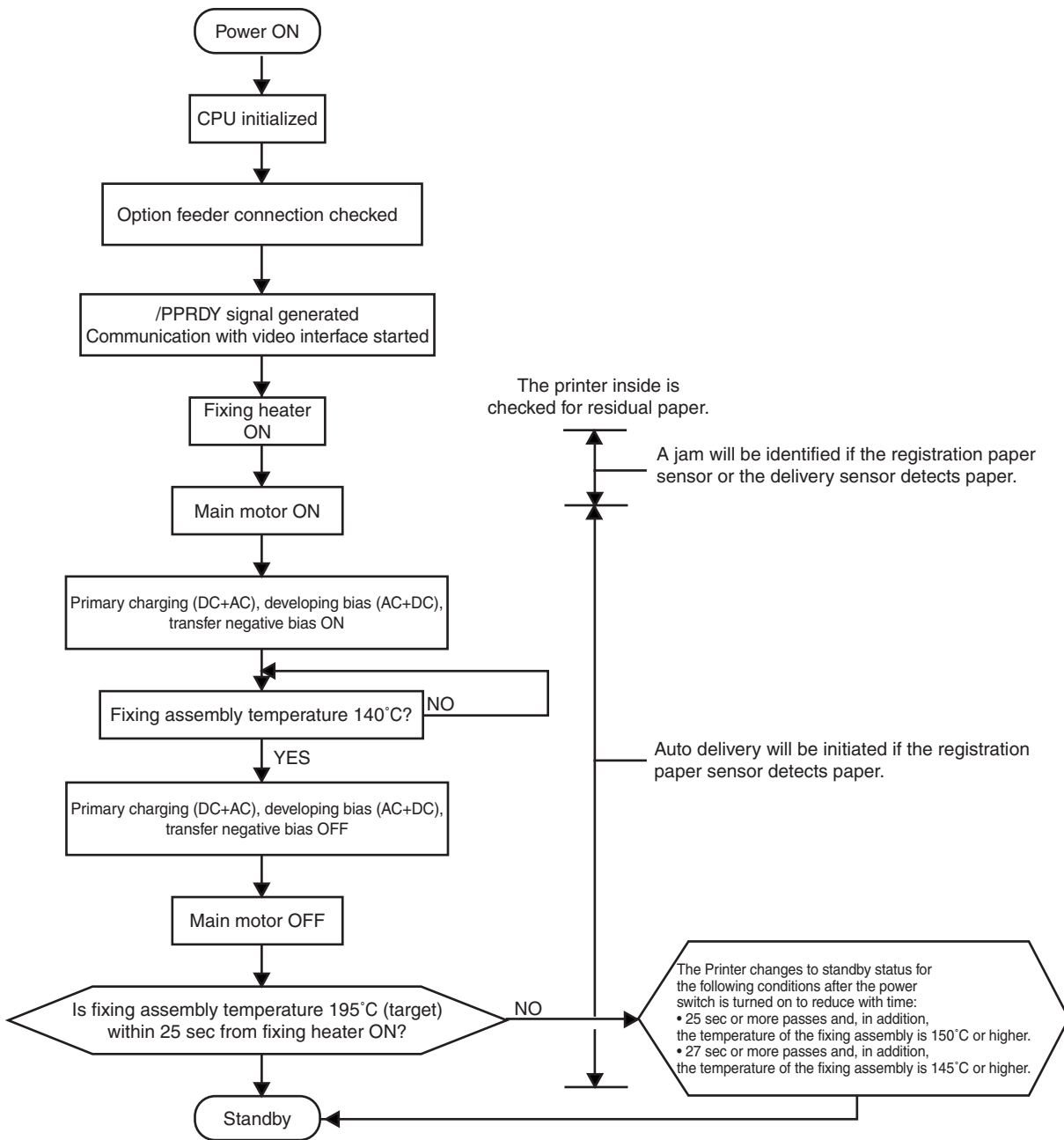

Figure 2-1-4

II. ENGINE CONTROL SYSTEM

A. Outline of the Electrical Circuitry

1. Outline

The sequence of operation of the Printer is controlled by the CPU found on the DC controller PCB. When the power switch is turned on and the Printer enters standby state, the CPU generates signals to drive such loads as laser diodes, motors, and solenoids in response to the print start command and image data from an external device. The following is a block diagram for the circuitry:

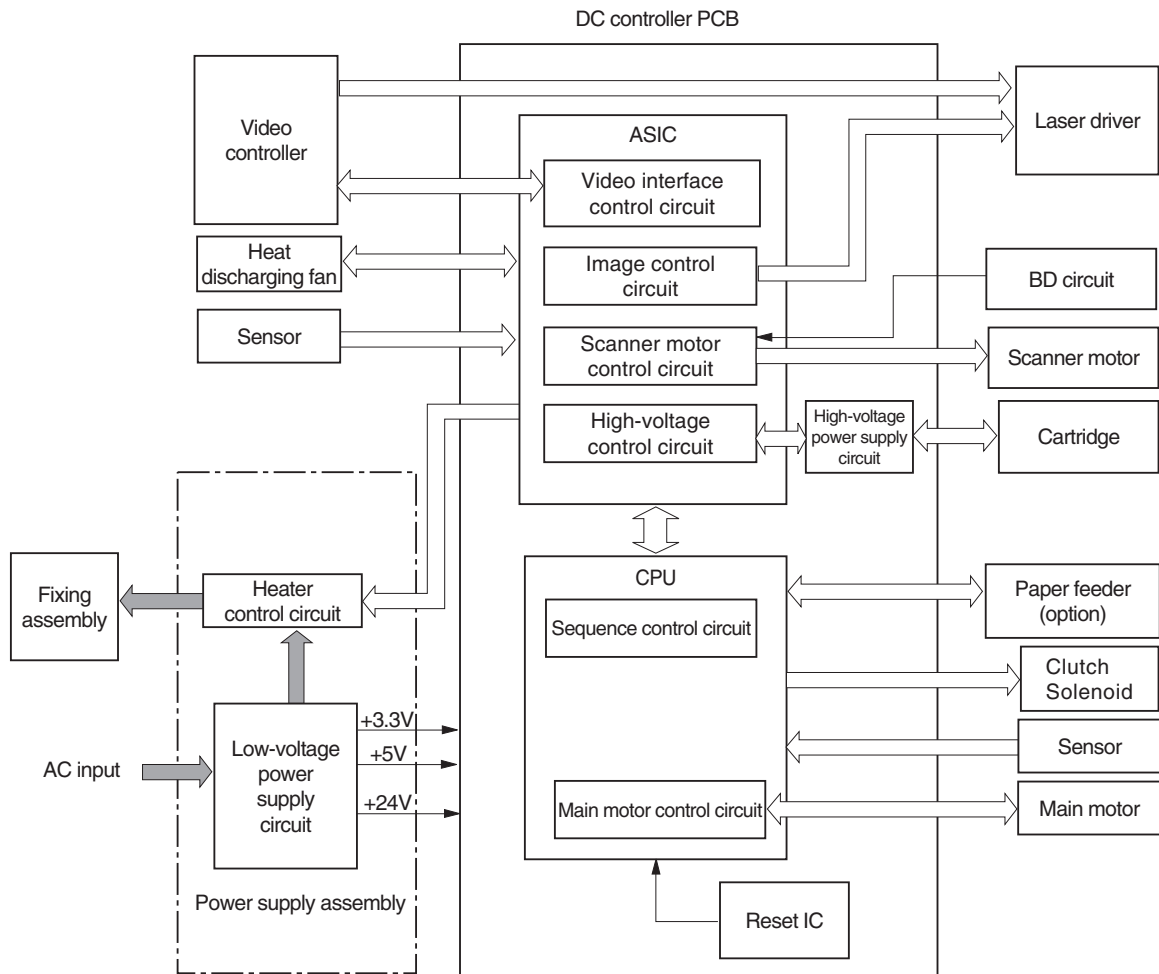

Figure 2-2-1

2. Operation within the block

a. CPU

The CPU is an 8-bit microprocessor. It is a single-chip type, possessing a built-in ROM and RAM; it performs the following operation of the Printer using ASIC according to the control program stored in ROM.

- 1) controlling the sequence of operation of the printer engine
- 2) controlling the registration sensor/delivery sensor
- 3) controlling the drive of the main motor/fan motor
- 4) controlling the cassette pickup clutch/registration clutch
- 5) controlling the multifeeder pickup solenoid
- 6) communicating with the paper feeder

b. ASIC

- 1) controlling the communication with the video controller PCB
- 2) controlling the high-voltage power supply circuit
- 3) controlling the laser/scanner
- 4) controlling the fixing heater
- 5) controlling the multifeeder paper sensor/paper size detecting switch

c. Reset IC

The reset IC monitors the +3.3V voltage and resets the CPU in a specific time if the power supply voltage reaches +2.7 V after the power is turned on or if it drops below +2.7 V while power is supplied.

d. Heater control circuit

For details, see C. 'Controlling the Fixing Mechanisms.'

e. High voltage power supply circuit

For details, see D. 'High-Voltage Power Supply Circuit.'

f. Low-voltage power supply circuit

For details, see E. 'Low-Voltage Power Supply Circuit.'

B. Inputs to and Outputs from the DC Controller

1. Inputs to the DC controller

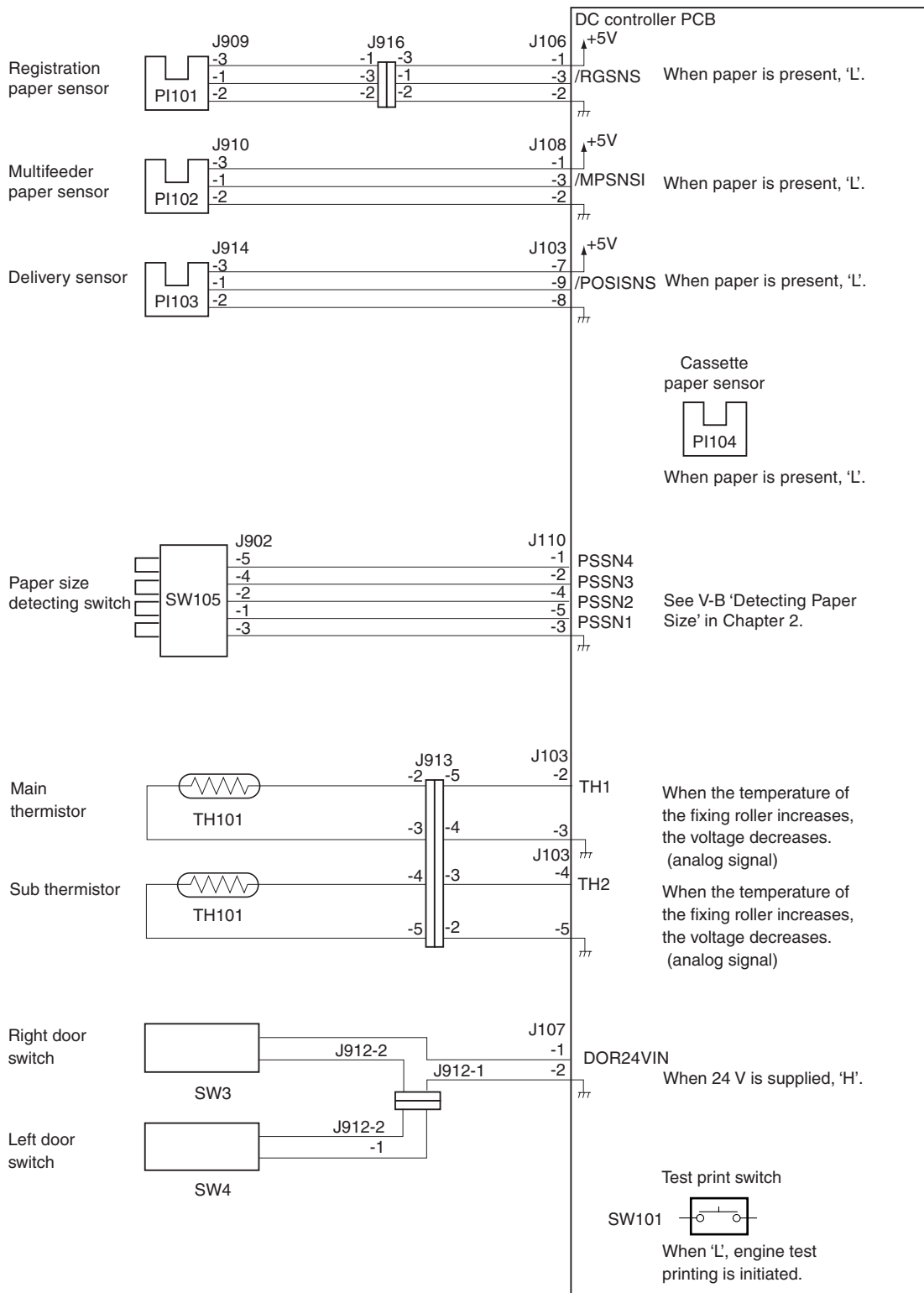

Figure 2-2-2

2. Outputs from the DC controller

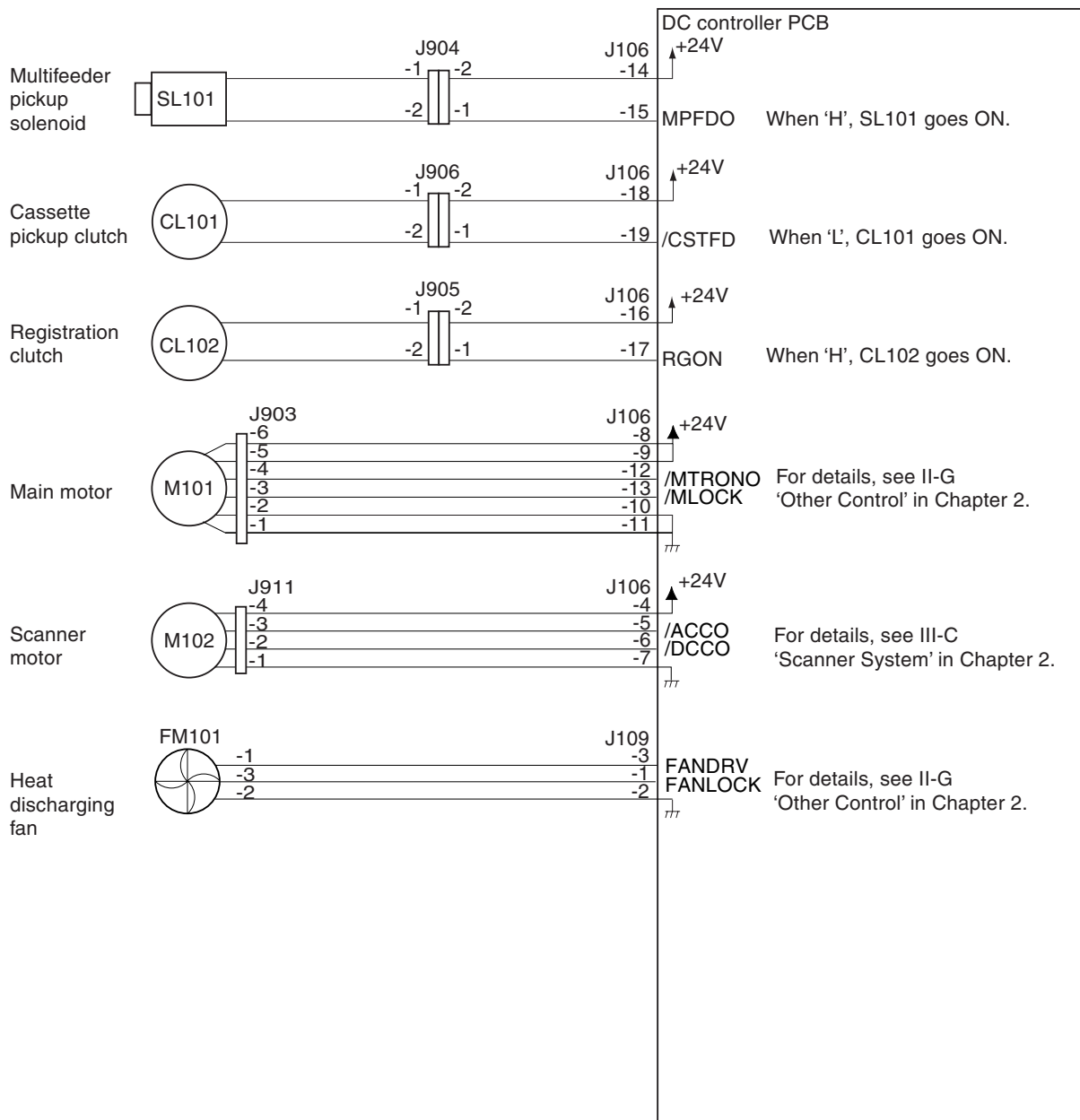

Figure 2-2-3

3. Inputs to and outputs from the DC controller

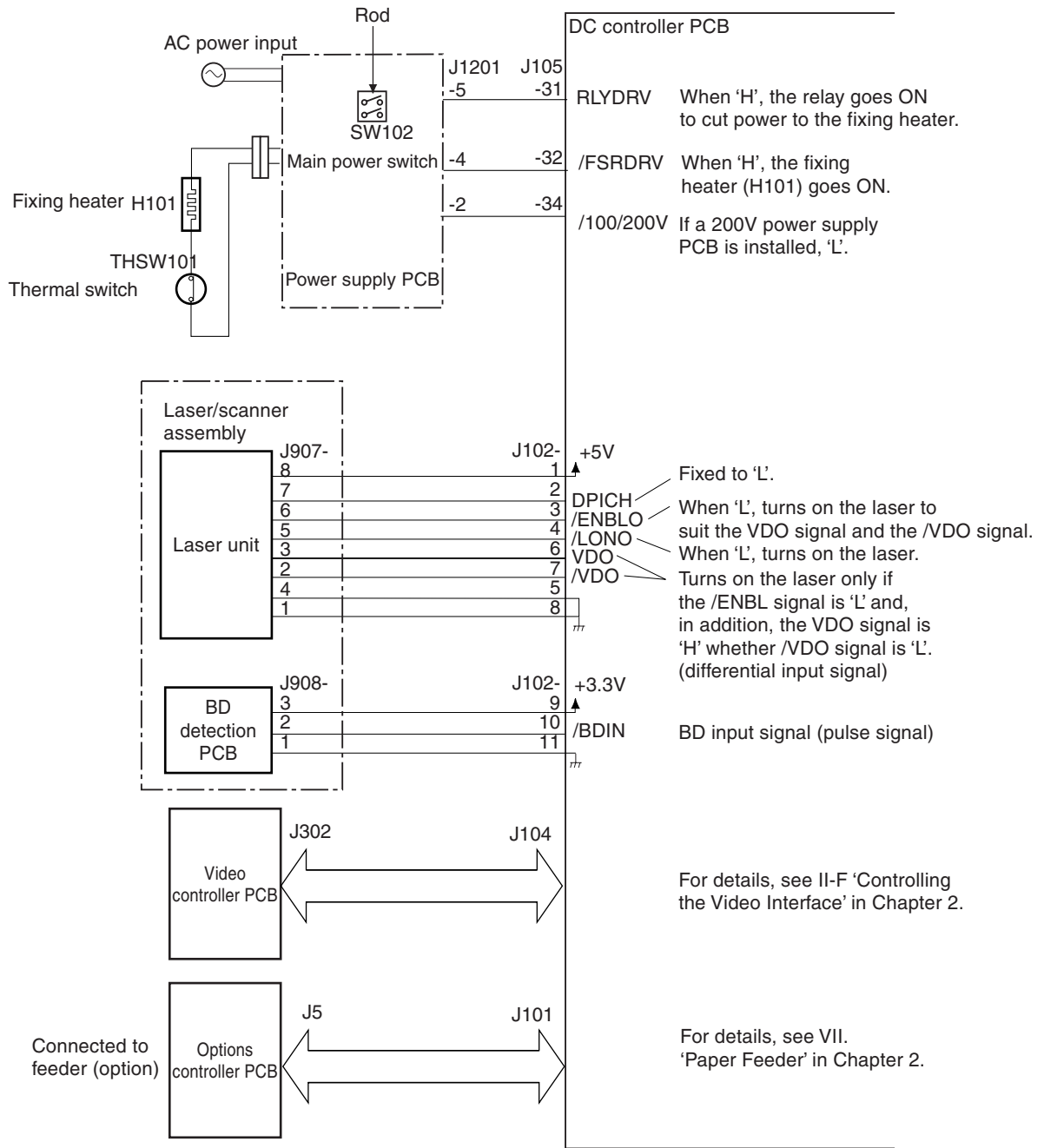

Figure 2-2-4

C. Controlling the Fixing Mechanisms

1. Outline

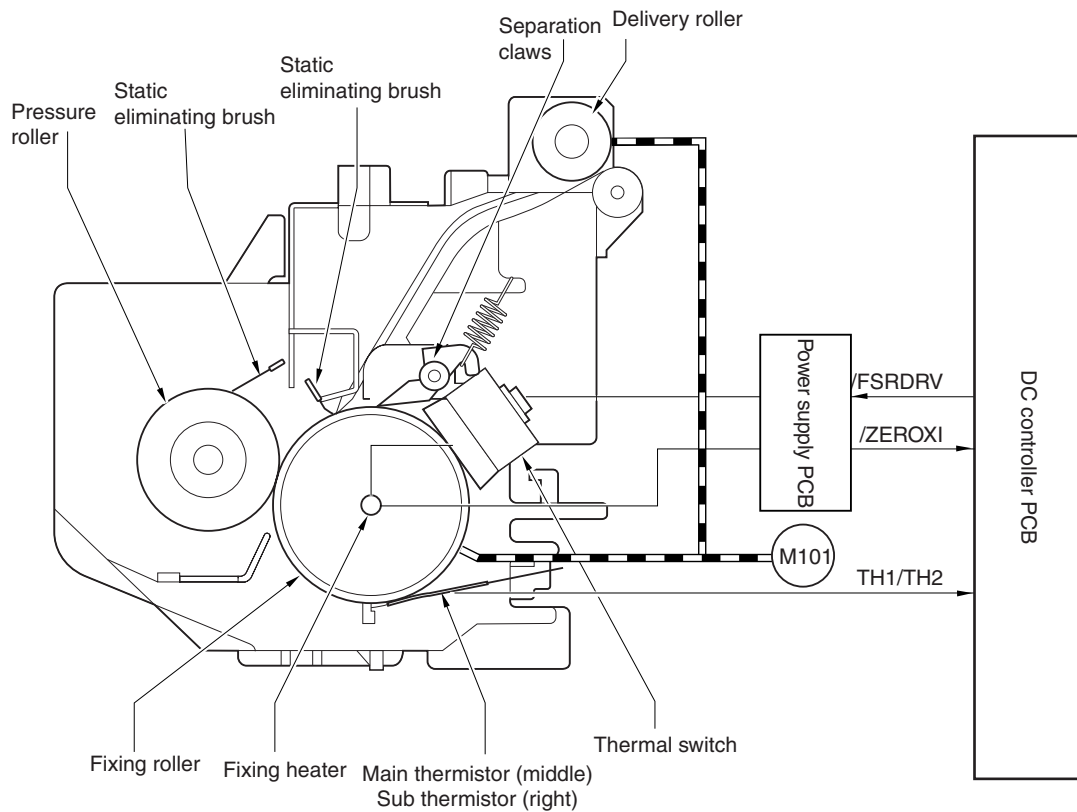

Figure 2-2-5

The fixing roller, pressure roller, and delivery roller of the fixing assembly are driven by the main motor (M101). The fixing roller is heated by a single fixing heater (H101; 800 W). The surface temperature of the fixing roller is monitored by the main thermistor and the sub thermistor; the main thermistor is used to check the middle of the fixing roller while the sub thermistor is used to check the right edge of the fixing roller.

When the surface temperature increases, the resistance of TH101 will decrease, causing the voltage of the main thermistor (TH1) and the sub thermistor signal (TH2) to decrease.

The DC controller PCB controls the fixing heater drive signal (/FSRDRV) based on the voltage level of the TH1 signal and the TH2 signal, thereby controlling the surface temperature of the fixing assembly to remain a specific level.

The FSRDRV signal is generated in relation to the zero-cross (/ZEROXI) signal from the zero-cross circuit found on the power supply PCB.

If the sub thermistor detects an increase in temperature at the end (thermistor reading of 210°C) as caused by the use of small paper in continuous printing, the Printer starts down sequence.

The Printer is equipped with sleep mode for energy conservation, and it turns off the fixing heater (H101) while it remains in sleep mode (power saving mode).

2. Controlling the fixing temperature

The fixing temperature is controlled in relation to the following:

- a. paper type
- b. power switch activation
- c. sleep mode (power saving mode)
- d. down sequence

a. Control by paper type

To ensure good fixing on rough paper and transparencies, the Printer's utility mode includes rough paper mode and transparency mode; for prevention of curling of paper, the Printer offers normal L mode, which uses a control temperature different from that used for plain paper.

Table 2-2-1

Mode	Control temperature during printing	Control temperature during standby	Remarks
Normal mode	175°C	173°C	
Rough paper mode	195°C	195°C	After receipt of /PRNT, the control temperature is held to 195°C and, at the same time, INTR is extended by 5 sec. Also, in continuous printing, the distance between sheets is increased.
Transparency mode	170°C	180°C	In continuous printing, the distance between sheets is increased.
Normal L mode	173°C	173°C	

- Note:**
- Normal mode is used when printing on plain paper (default).
 - Rough paper mode is used when printing on heavy paper or in a low temperature environment.
 - Transparency mode is used when printing on transparencies.
 - Normal L mode is used to prevent curling on plain paper L.

b. Control when turning on the power switch

(1) Conditions for ending the wait time

To reduce the wait time, the wait interval is ended when any of the following conditions exist, causing the Printer to move to standby state:

- 25 sec or more passes after the fixing heater (H101) is supplied with power and the fixing temperature reaches 150°C or higher.
- 27 sec or more passes after the fixing heater (H101) is supplied with power and the fixing temperature reaches 145°C or higher.

However, to ensure good fixing as soon as the power switch is turned on, the fixing heater is continuously kept ON even in standby state until the target temperature is reached.

(2) Controlling to the target temperature

To ensure good fixing as soon as the power switch is turned on, a target temperature is set in relation to the fixing temperature at power-on and the state of the Printer after power-on.

- **If the fixing temperature is less than 80°C when the power switch is turned on,**

When the /PRNT signal arrives in each mode, the target temperature is set higher than the control temperature. Printing is started when the target temperature is reached, and the target temperature is lowered in steps over time while continuous printing takes place, thereby using a control temperature specific to each mode.

If the /PRNT signal is absent, temperature control will be as in normal mode regardless of the selected mode.

- **If the fixing temperature is 80°C or higher when the power switch is turned on,**

When the /PRNT signal arrives in each mode, the control temperature is used as the target temperature. Printing is started when the target temperature is reached, and the target temperature is lowered in steps over time while continuous printing takes place, thereby using the control temperature specific to each mode.

If the /PRNT signal is absent, temperature control will be as in normal mode regardless of the selected mode.

c. Controlling in sleep mode (power saving mode)

The fixing heater (H101) remains OFF while the Printer is in sleep state. The target temperature at the end of sleep state is determined in relation to the fixing temperature and the state of the Printer, as in the case of temperature control at time of power-on.

Note: 1. Sleep mode (user menu) is set to 15 min at time of shipment from the factory.
2. Recovery control in response to the opening/closing of the front cover is the same as in sleep mode.

d. Down sequence

In continuous printing, the readings taken by the sub thermistor of the areas not in contact with paper can indicate overheating. To prevent overheating, the Printer increases the distance between sheets under the following condition (II-C-4-a. 'Thermistor (detecting overheating)'):

- Down sequence is started if the reading of the sub thermistor is 210°C or higher.
- Down sequence is ended at the end of continuous printing.

3. Fixing heater safety circuit

To prevent malfunction of the fixing heater, the Printer monitors the readings of the main thermistor and the sub thermistor at all times in relation to the ASIC and the high-temperature detection circuit found on the DC controller PCB.

In the event of an error, the Printer causes the relay drive signal (RLYDRV) to go Low, thereby turning off the fixing heater drive relay (RL1) found on the power supply PCB to cut the AC power to the fixing heater (H101).

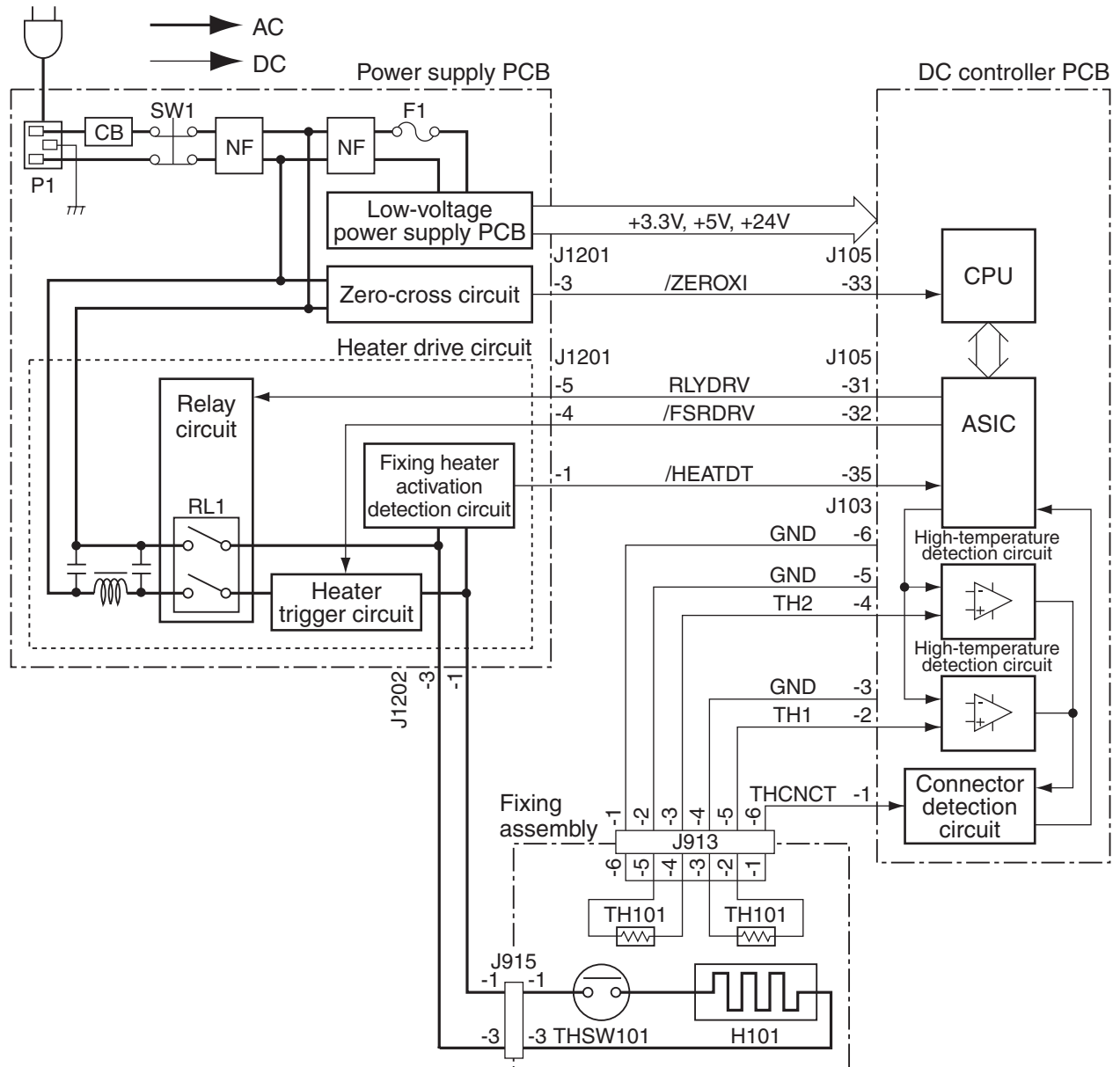

Figure 2-2-6

4. Protective functions

The printer is equipped with the following protective functions to prevent malfunction of the fixing heater:

a. Thermistor (detecting overheating)

The ASIC and the high-temperature detection circuit found on the DC controller PCB monitors the voltage readings of the main thermistor and the sub thermistor; if the main thermistor detects a voltage level which is equivalent of the following temperature, the CPU will identify the condition as being overheating:

- 220°C or higher (by main thermistor TH101)

b. Thermistor (detecting connector disconnection)

The connector disconnection detection circuit found on the DC controller PCB monitors the THCNT signal; if the THCNT signal goes Low, the CPU will identify the condition as indicating disconnection of the thermistor connector.

c. Thermistor (cutting the power for overheating)

If the internal temperature of the thermal switch (THSW101) exceeds about 230°C, thermal switch will go OFF, thereby cutting the power to the fixing heater.

d. Detecting the activation of the fixing heater

The fixing heater activation detection circuit found on the power supply PCB assumes that the /HEATDT signal is Low if the /FSRDRV signal is Low (fixing heater ON). If /HEATDT goes High while /FSRDRV signal is Low (fixing heater ON), the ASIC will identify the condition to be an error in the activation of the fixing heater (triac short circuit).

5. Detecting a fault in the fixing assembly

The CPU will identify a fault in the fixing assembly under any of the following conditions (a through e) and execute the following:

- 1) Causes the /FSRDRV signal to go High to cut the power to the fixing heater.
- 2) Causes the RLYDRV signal to go Low to turn off RL1 while at the same time communicating the presence of a fault to the video controller PCB, thereby indicating any of the following on the LCD in the control panel: 'E000', 'E001', 'E003', 'E808'.

Caution: If 'E000', 'E001', 'E003' or 'E808' is indicated, the information on the fault in the fixing assembly is retained in the NVRAM on the DC controller PCB even after the power switch has been turned off and then on. (Whether or not the code is indicated depends on the reading of the fixing roller temperature.) If the code is indicated, be sure to clear the fault information using service mode.
(See C. of VIII. in Chapter 1.)

a. Detecting a fault at power-up

- the main thermistor reading does not reach 60°C within 10 sec after it has exceeded 40°C
- the main thermistor reading does not reach 80°C within 10 sec after it has exceeded 60°C
- the main thermistor reading does not reach 100°C within 10 sec after it has exceeded 80°C
- the main thermistor reading does not reach 120°C within 10 sec after it has exceeded 100°C
- the main thermistor reading does not reach 140°C within 10 sec after it has exceeded 120°C
- the main thermistor reading does not reach 160°C within 10 sec after it has exceeded 140°C
- the main thermistor reading does not reach 180°C within 10 sec after it has exceeded 160°C
- the main thermistor reading does not reach 195°C within 10 sec after it has exceeded 180°C

b. Detecting an abnormally low temperature

- the main thermistor reading does not reach 40°C within 14 sec after the fixing heater has been turned on

c. Detecting an abnormally low temperature during temperature control

- the main thermistor reading drops below 100°C after the end of wait state
- the sub thermistor reading is 50°C or lower during standby

d. Detecting overheating

- the main thermistor reading is 220°C or higher

e. Detecting a fault in the drive circuit

- the /ZEROXI signal cycle of the power supply cannot be detected during initialization
- the /ZEROXI signal does not arrive for 3 sec continuously during temperature control
- a short circuit is detected in the triac by the ASIC

D. High-Voltage Power Supply Circuit
1. Outline

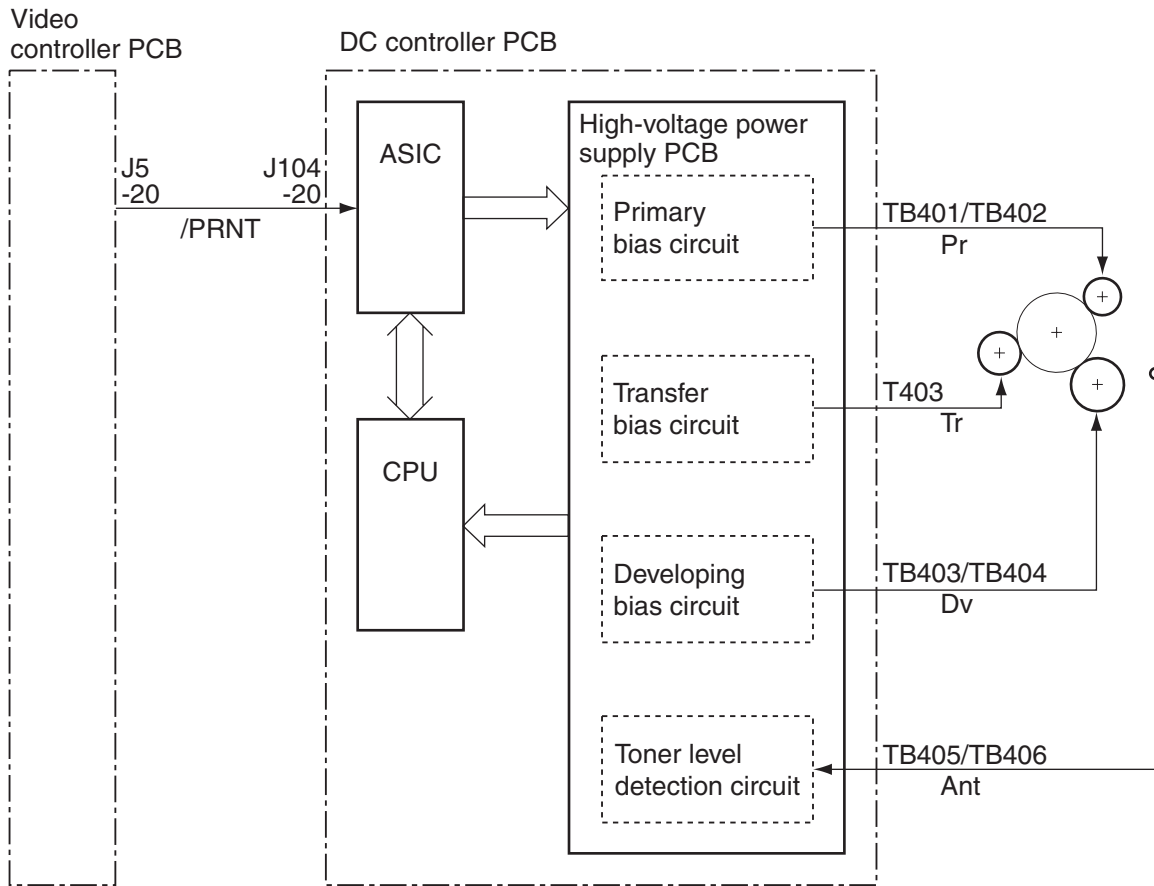

Figure 2-2-7

The high-voltage power supply circuit is mounted on the DC controller PCB, and is used to apply a voltage (generated by combining DC and AC voltages) to the primary charging roller and the developing cylinder in response to commands from the CPU and according to the print signal (/PRNT) from the video controller PCB; it applies a positive or negative DC voltage to the transfer charging roller.

It also varies the primary DC bias and the developing DC bias to adjust the image density based on the image density data from the video controller PCB.

• At power-on

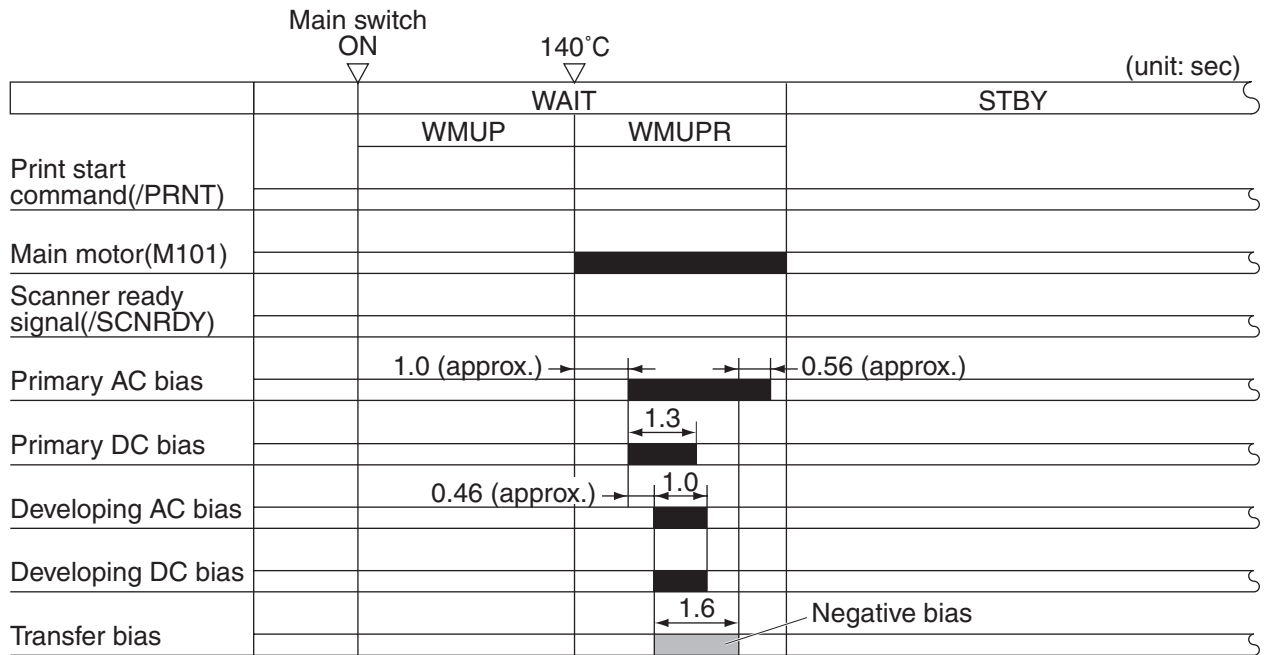

Figure 2-2-8

• During printing (A4, 2 pages, continuous)

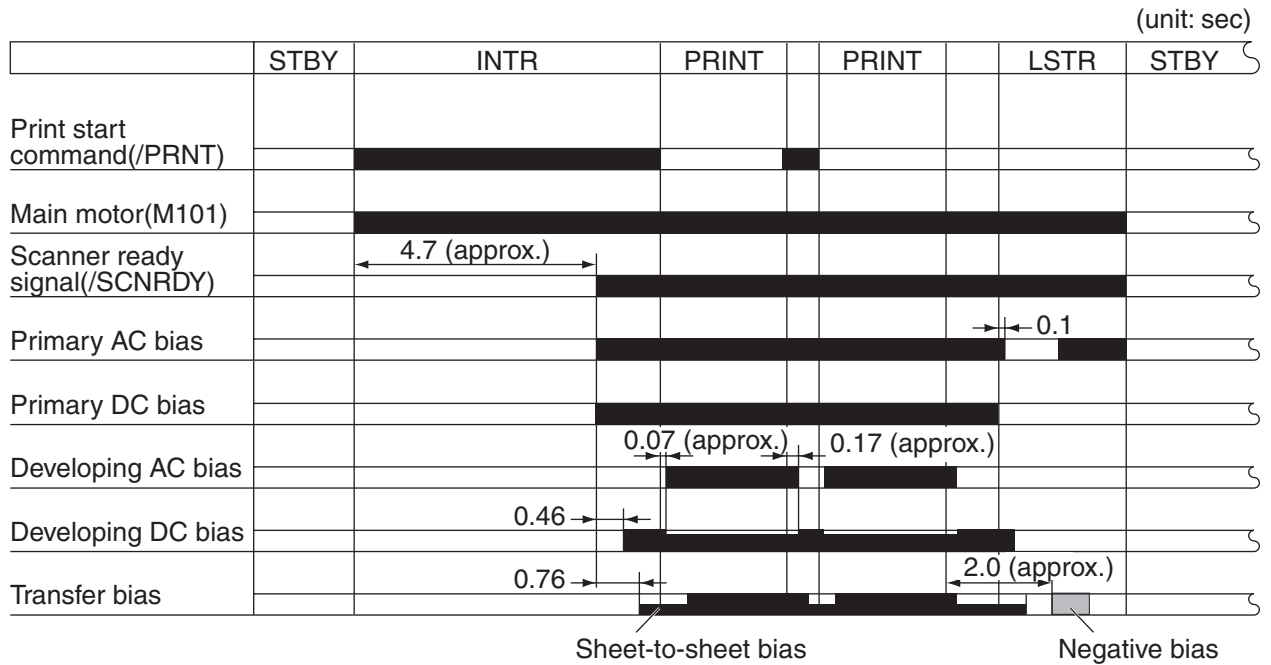

Figure 2-2-9

2. Operation
 a. Primary charging

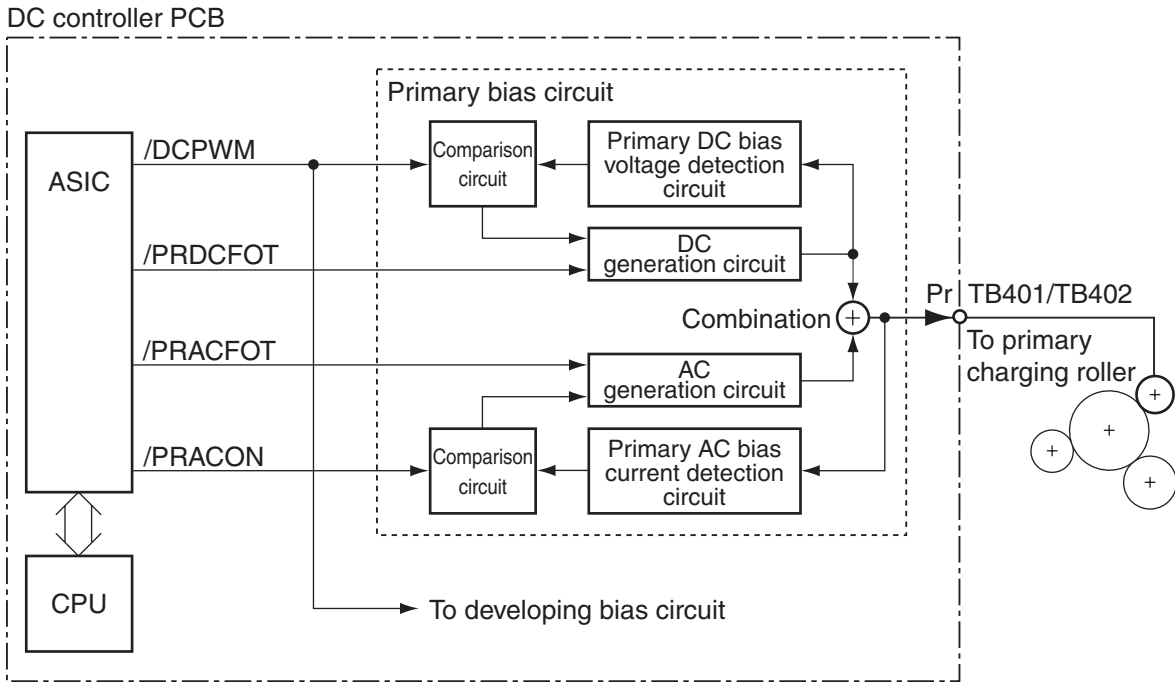

Figure 2-2-10

The ASIC generates the primary AC bias drive signal (/PRACFOT), the primary AC bias ON/OFF signal (/PRACON), the primary DC bias drive signal (/PRDCFOT), and the primary/developing DC bias output level signal (/DCPWM); it also applies a voltage which is a combination of a primary AC bias and a primary DC bias to the primary charging roller.

The primary AC bias is detected by the primary AC bias current detection circuit, and is fed back to the AC generation circuit by way of the comparison circuit, thereby controlling the current of the primary charging bias.

The primary DC bias is detected by the primary DC bias voltage detection circuit, and is fed back to the DC generation circuit by way of the comparison circuit, thereby controlling the voltage of the primary DC bias. The voltage of the primary DC bias is varied in conjunction with the voltage of the developing DC bias according to the image data from the video controller PCB.

b. Development

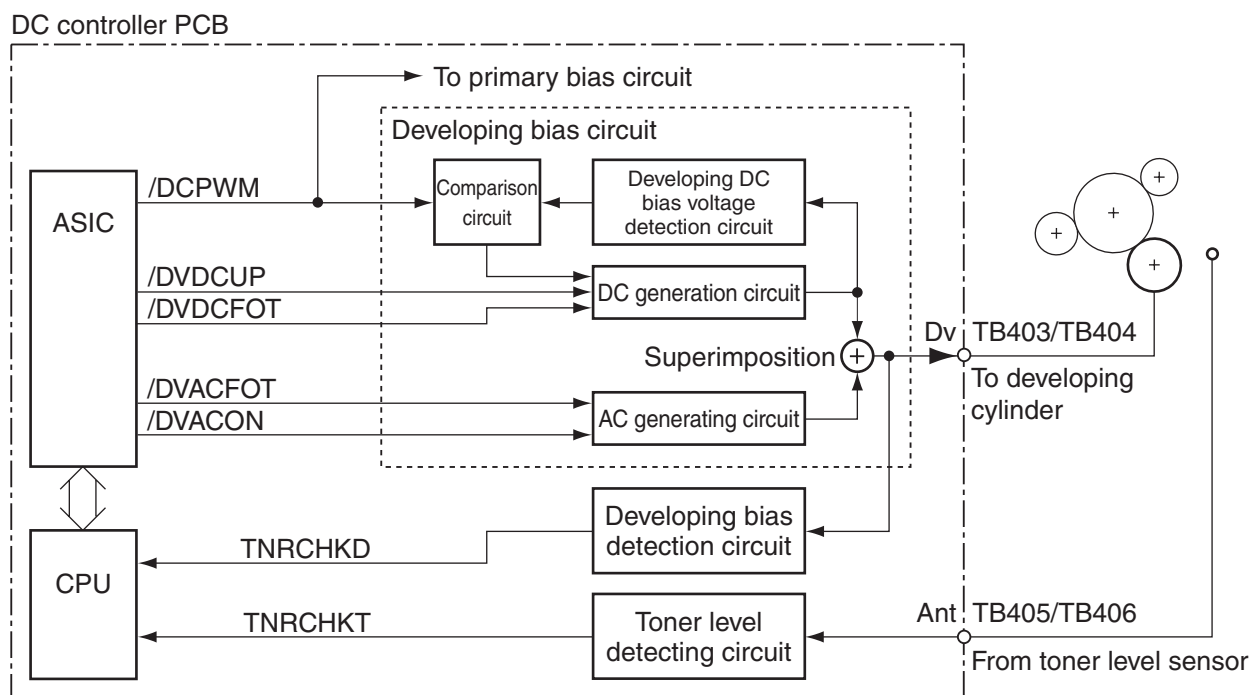

Figure 2-2-11

The ASIC generates the developing AC bias drive signal (/DVACFOT), developing AC bias ON/OFF signal (/DVACON), developing DC bias drive signal (/DVDCFOT), and primary /developing DC bias output level signal (/DCPWM), and applies a voltage which is a combination of a developing AC bias and a developing DC bias to the developing cylinder.

When not forming images, the developing DC bias output switch signal (/DVDCUP) is used to apply the developing DC bias (with a voltage higher than that used when forming an image) to prevent soiling of the pressure roller.

The developing DC bias is monitored by the developing DC bias voltage detection circuit, and is fed back to the DC generation circuit by way of the comparison circuit so that the Printer may control the voltage of the developing DC bias. The developing DC bias is varied in conjunction with the voltage of the primary DC bias according to the image density data from the video controller PCB.

c. Detecting the toner level and the presence/absence of a cartridge

A toner level sensor is mounted inside the cartridge.

The Printer collects readings (Ant) of the toner level sensor mounted inside the cartridge and the output (Dv) of the developing bias, and subjects them to A/D conversion.

The CPU checks the difference between the cartridge detection signal (TNRCHKD) and the toner detection signal (TNRCHKT) occurring after A/D conversion when the developing bias is applied to find out the level of toner and the presence/absence of a cartridge.

The presence/absence of a cartridge is checked only during a warm-up rotation interval. The level of toner is checked while the developing bias is applied during a warm-up interval and during an initial rotation interval. If the absence of toner is detected during control, retry control will be executed a maximum of three times. (Note 1)

If the absence of toner is detected for the three retry operations, the Printer will indicate the message 'READY TONER LOW' in its control panel.

- Note:**
1. If retry operation is executed three times as the result of toner level detection at power-on, about 40 sec of wait time will be required.
 2. As many as about 100 pages may be printed after the message 'READY TONER LOW' is indicated (i.e., about 60 g of toner remains).

d. Transfer

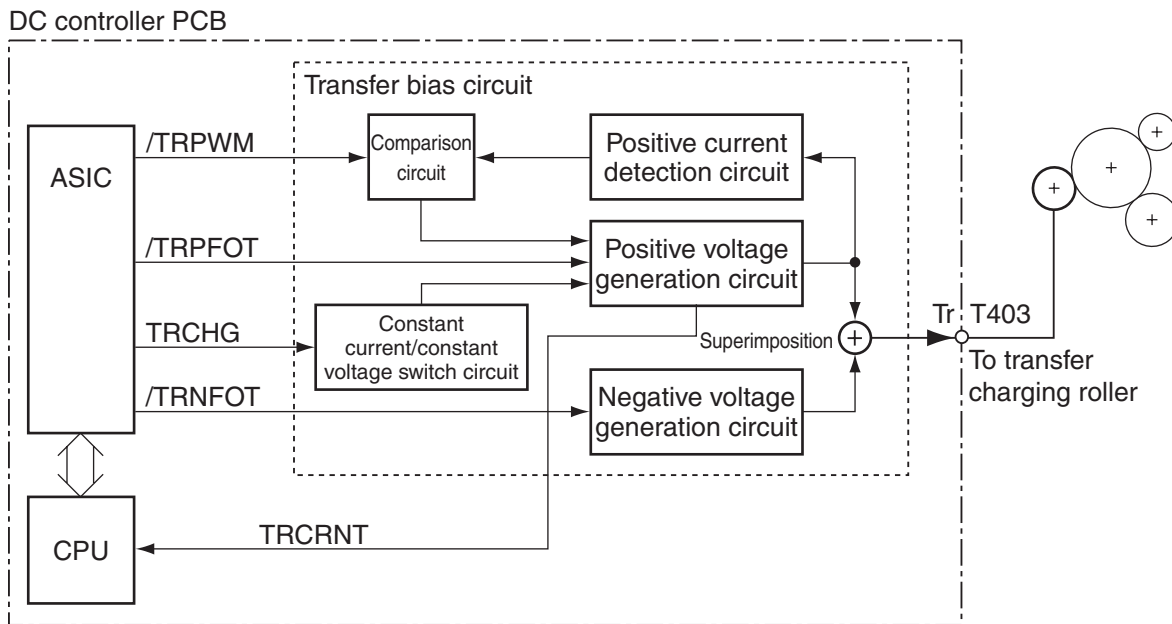

Figure 2-2-12

A negative bias, sheet-to-sheet bias, or positive bias is applied to the transfer charging roller to suit the ongoing sequence. The negative bias is applied at such times as needed to move the toner from the transfer charging roller to the photosensitive drum by way of cleaning the roller. The sheet-to-sheet bias is applied at such times as necessary, is of a voltage lower than that used for printing, and is used to prevent residual toner on the photosensitive drum from sticking to the transfer charging roller. The positive bias is controlled as necessary, is a positive voltage, and is used to transfer toner from the photosensitive drum to paper.

E. Low-Voltage Power Supply Circuit
1. Outline

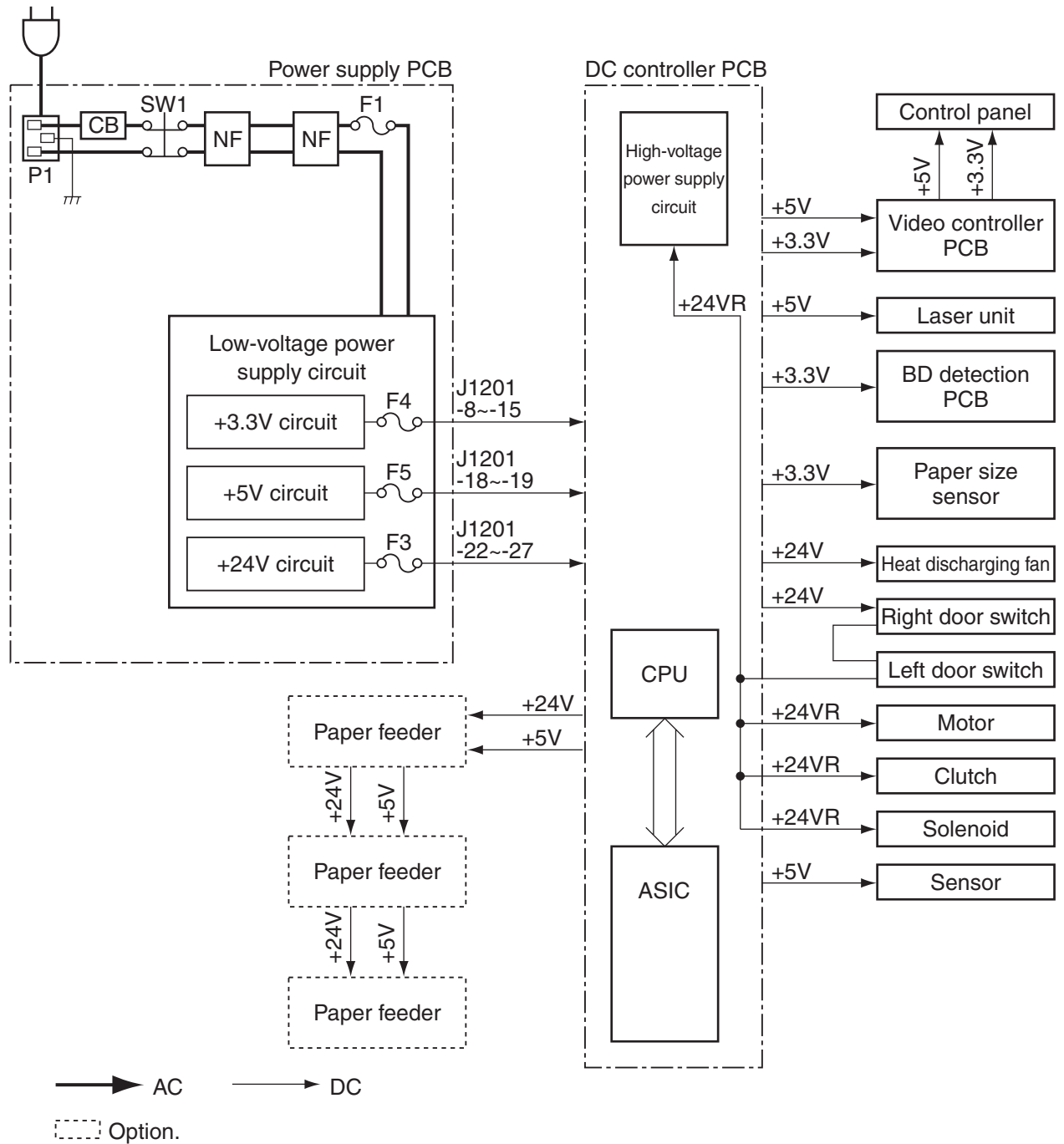

Figure 2-2-13

The AC power arriving at the low-voltage power supply circuit on the power supply PCB is converted into three power levels (+24 V, +5 V, +3.3 V), and is sent to the DC controller PCB.

The +24 V may be either of the following two: +24 V which is stopped when the right door switch (SW3) or the left door switch (SW4) is turned off (i.e., the front cover is opened), and +24 V which is supplied regardless of the state of these switches.

The range of voltage levels arriving at the power supply PCB, rated outputs, and tolerances are as follows:

- Input voltage level range: AC input $\pm 10\%$, 50/60 Hz $\pm 2\%$
- Rated output and tolerance: +3.4 V $\pm 3\%$; +5.1 V -4%, +3%; +24.0 V -5%, +10%

2. Protective mechanisms

The power supply PCB is equipped with overcurrent protective functions and over-voltage protective functions, which are used to protect the power circuit from damage by automatically cutting the output power in response to an overcurrent or an error voltage caused by a short-circuit or the like in any of the loads.

If the output power is cut, turn off the power switch, disconnect the power plug, remove the cause of activation, and leave the Printer alone for about 3 min or more before turning on the power once again, thereby resetting the protective circuit.

The power supply PCB is also equipped with four fuses, which will blow if overcurrent flows into the power line.

3. Sleep mode (power saving mode)

The Printer enters sleep mode in response to a command from the video controller PCB to save on its power consumption.

When a sleep mode command arrives from the video controller PCB, the CPU cuts power to the loads and sensors (+24 V, +5 V), causing the Printer to enter the following state:

- Fixing temperature: stop
- Fan: stop
- Motors/sensor: stop

The Printer returns to normal state when a command arrives from the video controller PCB to end sleep mode when the /PRNT signal occurs or the Online key is pressed. (Note)

Note: When returning from sleep mode to normal mode (standby), the Printer executes initial sequence (warm-up and warm-up rotation), requiring a maximum of about 30 sec for recovery.

F. Video Interface Control

1. Outline

The following explains the types of interface signals used between the DC controller circuit and the video controller circuit, and provides an outline of operation sequence executed using these interface signals.

a. System block diagram

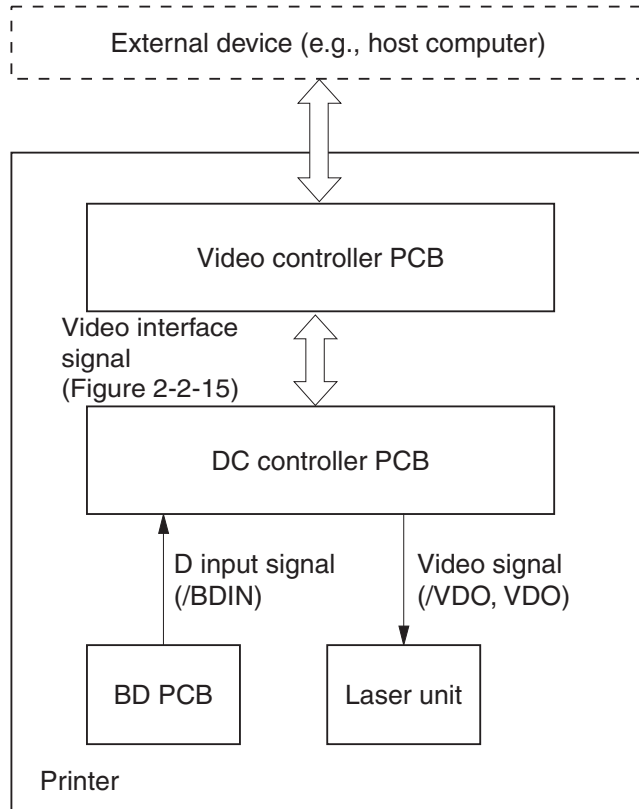

Figure 2-2-14

b. Video interface signals

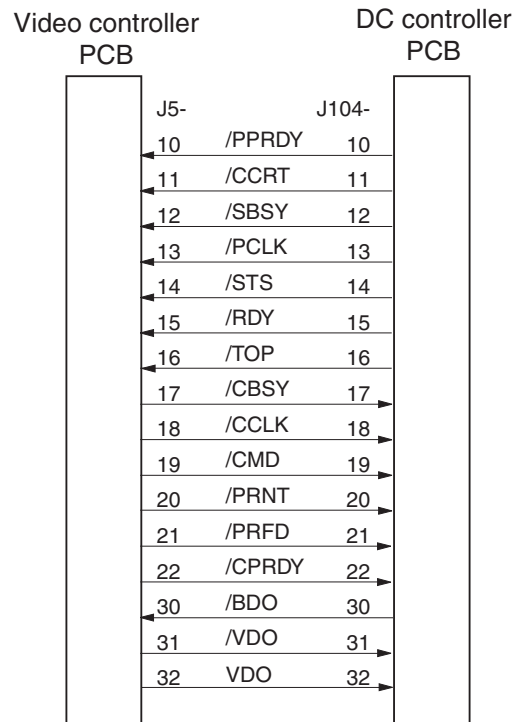

Figure 2-2-15

When the power switch is turned on, the Printer enters wait state (WAIT).

When WAIT ends and warm-up rotation ends, the DC controller sends the ready signal (/RDY) to the video controller, indicating that the Printer is ready for printing.

The video controller sends the print signal (/PRNT) to the controller when the /RDY signal goes Low and, in addition, data is ready for printing a single page.

When the /PRNT signal arrives, the DC controller starts the sequence for initial rotation (INTR).

When the sequence for initial rotation ends, the DC controller sends the vertical sync request signal (/TOP) to the video controller.

In response to the horizontal sync signal (/BDO) from the DC controller, the video controller sends video signals (/VDO, VDO) synchronized with the /BDO signal and the /TOP signal to the laser driver by the DC controller.

These video signals (/VDO, VDO) are sent to the laser driver as two low-voltage differential signals.

The laser driver uses these video signals (/VDO, VDO) to turn on or off the laser diode.

The latent image on the photosensitive drum is transferred to paper as part of electrophotographic processes, and the output is delivered face-down.

While a single page is being printed, the DC controller checks the presence of /PRNT signal from the video controller. If not, the Printer stops the print sequence, and starts last rotation (LSTR), at the end of which it enters standby state (STBY).

If the /PRNT signal is detected, the Printer continues the print sequence until the /PRNT signal stops, at which time it will execute last rotation and enter standby state.

G. Other Control

1. Controlling the main motor

The following shows the circuit used to control the main motor:

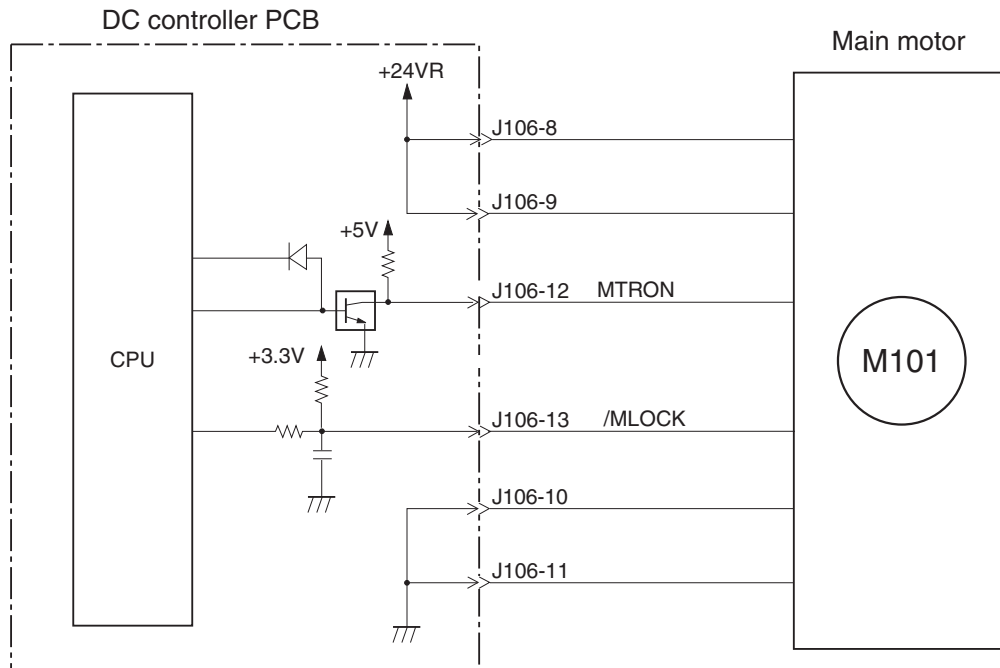

Figure 2-2-16

The main motor is a 3-phase DC brushless motor with a built-in Hall element, and is mounted to the motor drive PCB.

The CPU causes the main motor drive signal (MTRON) to go High to rotate the main motor. When the main motor starts to rotate and reaches a specific revolution, it causes the main motor rotation detection signal (/MLOCK) to go Low.

The CPU will identify a fault in the main motor under any of the following conditions, communicating to the video controller and indicating 'E011' on the LCD of the control panel:

1. At the start of warm-up rotation (WMUPR), the /MLOCK signal does not go High within 2 sec.
2. 1.25 sec after the main motor is started, the /MLOCK signal is continuously High for 0.1 sec or more.
3. 2 sec after the main motor is started, the /MLOCK signal is continuously Low for 0.1 sec or more.

2. Controlling the fan motor

The Printer is equipped with a single fan used to discharge heat from inside the machine. The heat discharging fan (FM101) is controlled by the following circuit and at such times as indicated:

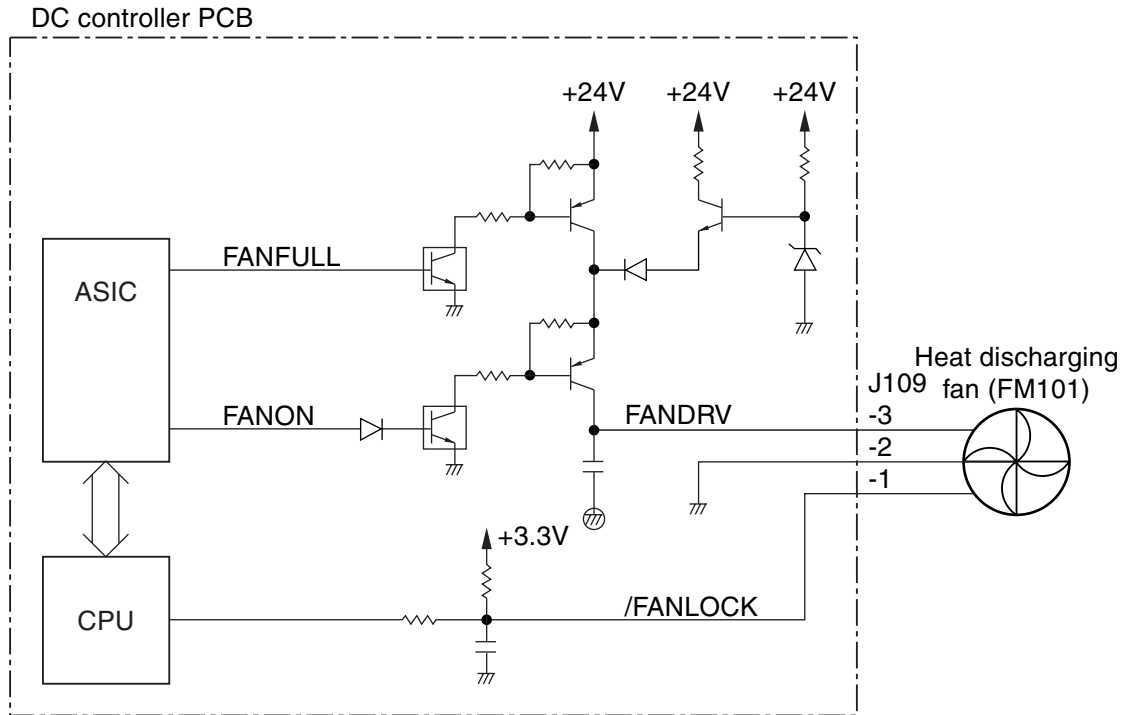

figure 2-2-17

- A4, 2 Pages, Continuous

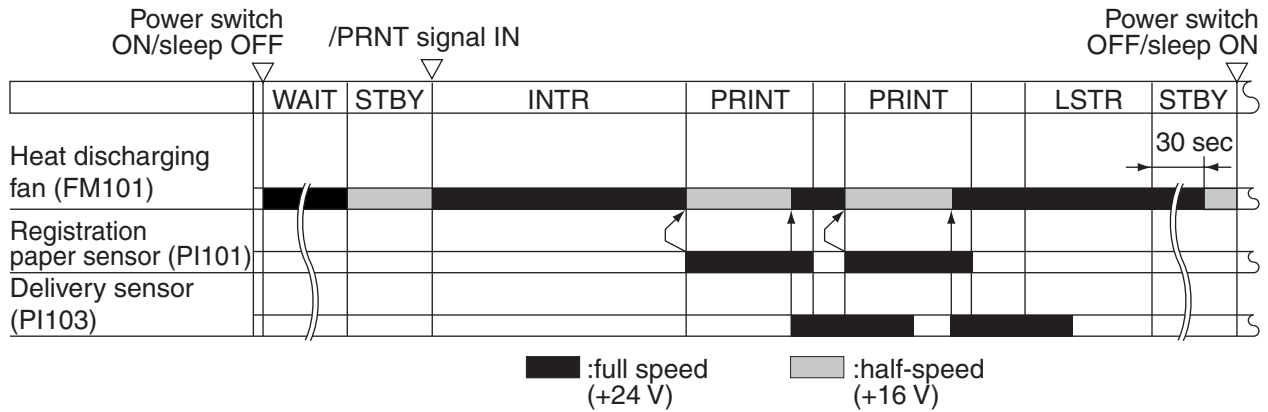

Figure 2-2-18

When the power switch is turned on or when sleep state is ended, the fan ON signal (FANON) goes High and the fan full-speed rotation signal (FANFULL) goes High; the Printer supplies the fan drive voltage (FANDRV; about 24 V) to rotate the heat discharging fan at full speed. The Printer also rotates the heat discharging fan at full speed for 30 sec after the end of last rotation (LSTR) and between sheets.

While printing takes place or while in standby, the Printer causes the fan full-speed rotation signal (FANFULL) to go Low, and supplies the fan drive voltage (FANDRV; about 16 V) to rotate the discharging fan at half speed.

The CPU monitors the fan lock detection signal (/FANLOCK) at all times while the heat discharging fan is rotating; if the /FANLOCK signal is Low for a specific period of time or longer, the CPU will identify the condition as indicating a fault in the heat discharging fan, and will communicate the fact to the video controller and indicate 'E805' on the LCD in the control panel.

Table 2-2-5

Signal	Stop	Half-speed rotation	Full-speed rotation
Fan ON signal (FNAON)	0	1	1
Fan full-speed rotation signal (FANFULL)	0	0	1

III. LASER/SCANNER SYSTEM

A. Outline

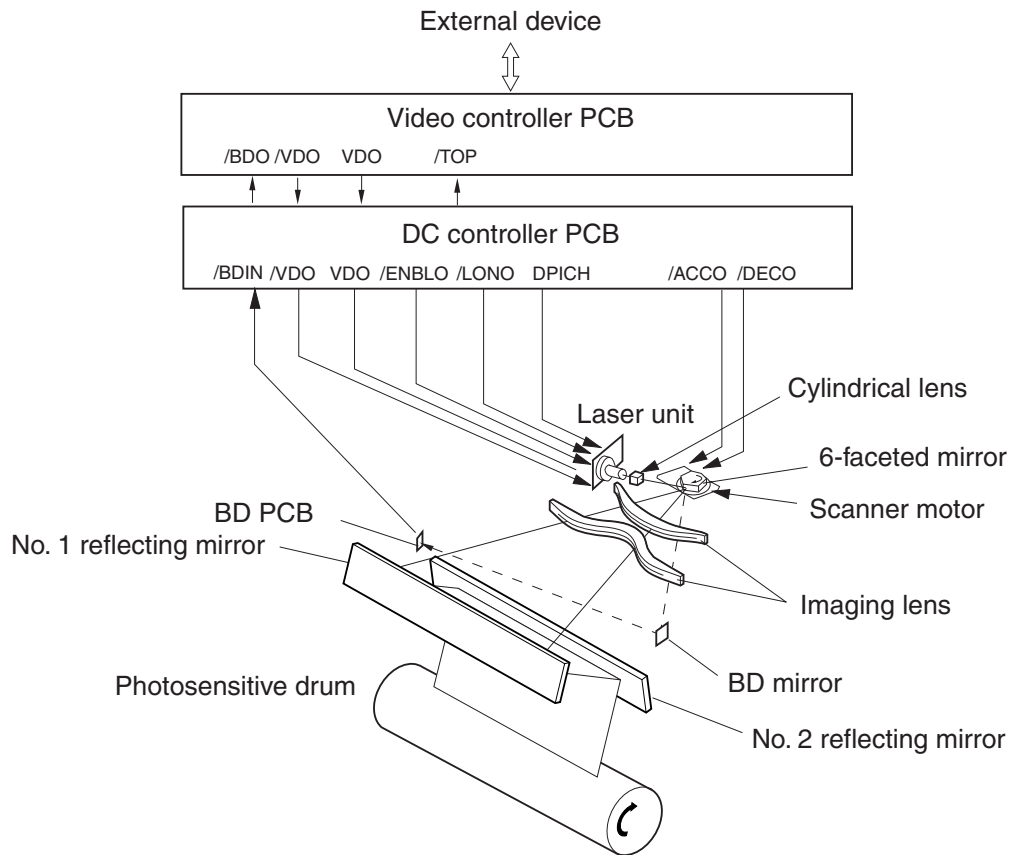

Figure 2-3-1

The video signals (/VDO, VDO) from the video controller are sent to the laser driver of the laser/scanner assembly by way of the DC controller.

If the image formation enable signal (/ENBLO) from the DC controller is 'L', the laser driver turns on/off the laser diode according to the video signals (/VDO, VDO) to generate a modulated laser beam.

The modulated laser beam is turned into a parallel beam by the work of the collimator lens and the cylindrical lens, and is directed to the 6-faceted mirror, which is rotating at a specific speed.

The laser beam reflected by the 6-faceted mirror is guided to the imaging lens and the reflecting mirror mounted in front of the 6-faceted mirror, ultimately reaching the photosensitive drum.

When the 6-faceted mirror rotates at a specific speed, the laser beam on the photosensitive drum accordingly scans the drum surface.

As the photosensitive drum rotates at a specific speed and, in addition, when the laser beam scans its surface at a specific speed, an image emerges on the drum surface.

B. Laser Control Circuit

1. Outline

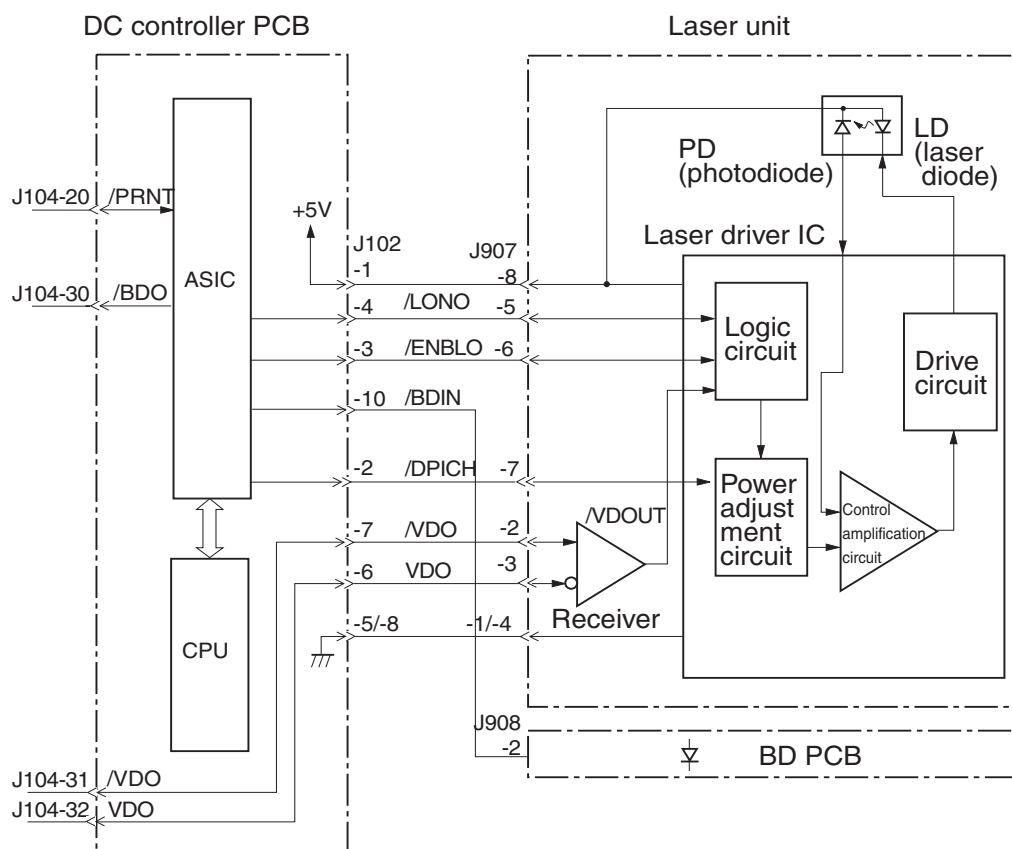

Figure 2-3-2

The laser control circuit operates in response to the video signals (/VDO, VDO) from the video controller to turn on/off the laser diode (LD) at a specific intensity.

The /VDO and VDO signals from the video controller are low-amplification differential signals with suppressed radiating noise, and they are sent to the receiver in the laser unit as they are. The receiver serves to demodulate the low-voltage differential signals and to forward them to the logic circuit of the laser driver IC in the form of the video out signal (/VDOUT).

When the image formation enable signal (/ENBLO) from the ASIC is 'L', the laser unit turns on/off the laser diode in keeping with the /VDOUT signal.

2. Controlling the automatic emission of the laser diode

The automatic emission mechanism (APC) of the laser diode is controlled by the laser driver IC, ensuring that the laser diode emits light of a specific intensity.

When the laser forced emission signal (/LONO) goes 'L' or the image formation enable signal (/ENBLO) and the /VOUT signal go 'L', the laser diode is turned on in keeping with the reference voltage of the laser driver PCB.

The photodiode of the laser diode receives the laser light, and feeds it back to the control amplification circuit of the laser driver IC for comparison against the current level determined by the power adjustment circuit, thereby controlling the laser current flowing to the laser diode.

The machine uses an APC method in which its laser driver detects and controls, for each dot, the intensity of light at all times as long as the laser diode remains ON.

3. Controlling the horizontal synchronization

The ASIC generates the un-blanking signal inside it using the BD input signal (/BDIN) coming from the BD PCB mounted to the laser/scanner assembly.

The ASIC causes the laser forced emission signal (/LONO) to go 'L' during the un-blanking period, and the laser driver turns on the laser diode when the /LONO signal is 'L'.

A small fixed mirror (BD mirror) is mounted in the optical path where the laser beam starts a scan, and it is used to reflect the laser beam turned on by the /LONO signal and to detect it to the BD PCB inside the laser/scanner assembly.

The BD PCB detects the laser beam, and generates the BD input signal (/BDIN), and sends the output to the ASIC, which generates the horizontal sync signal (/BDO) based on the /BDIN signal for use by the video controller.

4. Controlling the emission of the laser diode

In keeping with the paper size information from the CPU, the ASIC generates the image formation enable signal (/ENABLO), and sends it to the logic circuit of the laser driver IC. The /VDOUT signal is masked by the /ENABLO signal in the logic circuit so that the length of time during which the laser diode emits light is controlled.

The paper size information is sent to the CPU in the form of the paper size selection command from the video controller in the case of the multifeeder or from the cassette size detection switch in the case of the cassette.

From the contents of the paper size information, the ASIC sends readings on leading edge erase/trailing edge erase and left/right image mask settings to the ASIC.

In response, the ASIC generates the image leading edge erase/trailing edge erase (TOPE) and left/right image mask signal (MSK); TOPE and MSK are used within the ASIC, and are not sent outside it.

To prevent writing by the laser beam outside the non-image area except during the un-blanking period), it causes the image formation enable signal (/ENBLO) to go 'L' while the TOPE signal and the MSK signal remain 'L'.

The laser driver turns on the laser diode when the /ENBLO signal is 'L' and, in addition, the /VDOUT signal is 'L'.

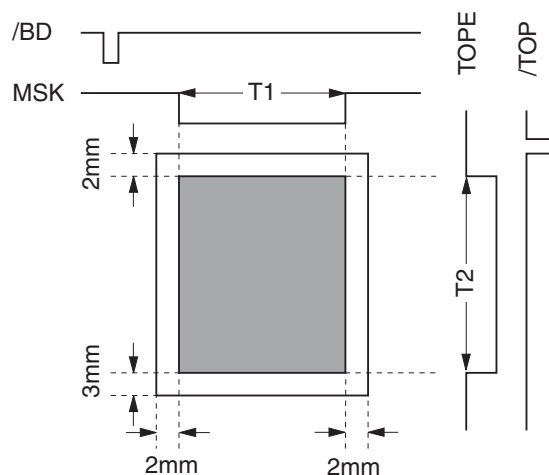

Figure 2-3-3

- Note:**
1. The shading indicates the area in which writing by the laser beam is possible.
 2. T1 and T2 lengths of time vary according to paper size.

If no specific paper is identified by the paper size selection command coming from the video controller when the multifeeder tray is used, the printer will have no means of knowing the paper width (T1), automatically identifying the width to be 293 mm (which is the result of subtraction of 2 mm (left and right each) from the width assigned to the universal size paper cassette (maximum width allowed by the machine: 297 mm)).

C. Scanner System

1. Controlling the scanner motor

The following is a diagram of the scanner motor control circuit:

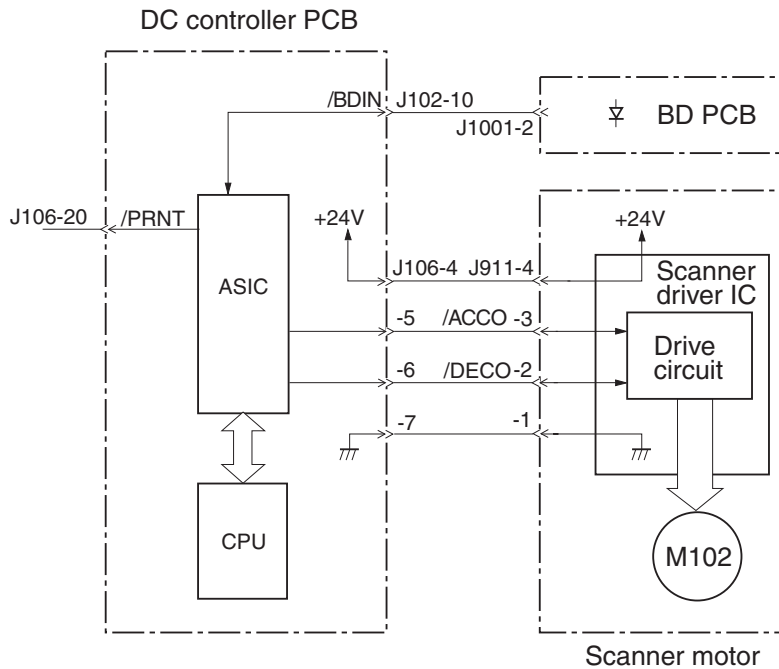

Figure 2-3-4

The scanner motor is a 3-phase, 8-pole DC brushless motor with a built-in Hall element, and it is built as one with the driver circuit of the scanner motor.

When the ASIC receives the /PRINT signal from the video controller, it causes the scanner motor acceleration signal (/ACCO) to go 'L' in 0.15 sec. When the /ACCO signal goes 'L', the scanner driver IC rotates the scanner motor, and increases the speed of its rotation while the /ACCO signal remains 'L'.

While the scanner motor is rotating, the ASIC forces the laser ON, causing the BD PCB to send the /BDIN signal.

The ASIC compares the cycle of the /BDIN signal and the target cycle inside, and continues to control the rotation of the scanner by controlling the /ACCO signal until the rotation reaches a specific speed.

To stop the scanner, the scanner motor deceleration signal (/DECO) is caused to go 'L', thereby slowing down the rotation of the scanner until it comes to a stop.

The CPU monitors the /BDIN signal coming from the BD PCB to find out whether the scanner motor is rotating at a specific speed of rotation.

The CPU will identify any of the following conditions to be a scanner unit fault, and will communicate the fact to the video controller and indicate 'E110' on the LCD in the control panel.

1. The /BDIN signal is absent for 10 msec continuously when the scanner motor is started up or turned off.
2. The /BDIN signal is absent within 0.5 sec after the laser is tuned on when the scanner motor is started up.
3. The rotation of the scanner motor fails to reach 97% of the target rotation 7 sec after the scanner is started up.
4. The speed of the scanner motor is higher than the target speed for at any print within 20 sec after the motor is slowed down, as found to be too fast at time of start-up.
5. The cycle of the /BDIN signal deviates more than $\pm 2\%$ for a cumulative period of 10 mm (equivalent of print length) when image masking is under way or image masking is turned off while the motor is rotating at a constant speed.
6. The cycle of the /BDIN signal deviates by more than $\pm 2\%$ when image masking is under way while the motor is rotating at a constant speed.

2. Scanner pre-rotation

To ensure that the rotation of the scanner motor stabilizes fast at time of start-up, the machine rotates the scanner motor by sending the scanner pre-rotation command about 4.25 sec (varies depending on the image data reception time) in advance of the pickup command (/PRNT) sent by the video controller to the ASIC, ultimately ensuring the correct positioning of the image leading edge.

The following diagrams show the timing of operation used for delivery (A4, horizontal); the timing, however, varies depending on the timing of previous delivery and the printer settings:

Scanner Pre-Rotation ON

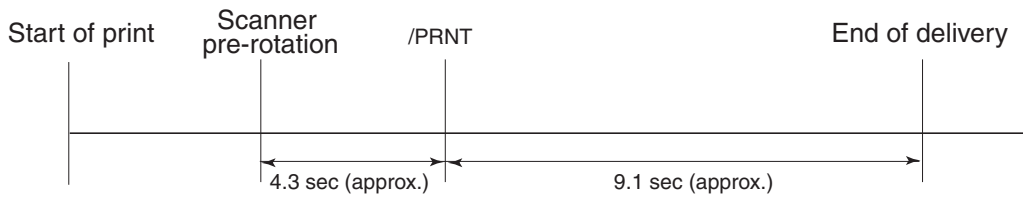

Scanner Pre-Rotation OFF

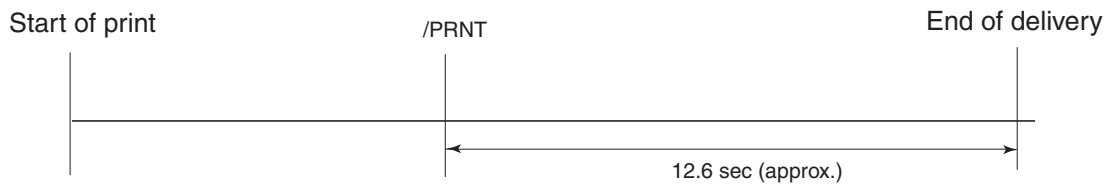

Figure 2-3-5

The machine issues the scanner pre-rotation command for the following condition:

- There is no previous image data and, in addition, no paper is being delivered and no page is being delivered.

IV. IMAGE FORMATION SYSTEM

A. Outline

The image formation system is the core of the Printer, and consists mainly of a cartridge and a fixing assembly.

When the video controller PCB sends the print signal (/PRNT) to the DC controller PCB, the DC controller PCB drives the main motor (M101) to start rotating the photosensitive drum, developing cylinder, primary charging roller, and transfer charging roller.

Thereafter, the primary charging roller charges the surface of the photosensitive drum to a uniform, negative potential; a laser beam modulated according to video signals (/VDO, VDO) is then directed to the surface of the Photosensitive drum to form a latent image.

The latent image is then turned into a visible image on the developing cylinder using toner; the resulting visible image is then transferred to paper by the transfer charging roller.

The surface of the photosensitive drum is cleaned by the cleaning blade, which removes residual toner; it is then charged to a uniform potential by the primary charging roller to be ready for a new image.

The cartridge of the Printer is equipped with a toner level sensor used to check the level of toner and the presence/absence of the cartridge.

When the toner inside the cartridge drops below a specific level or the cartridge is not fitted to the Printer, the fact will be communicated to the video controller PCB.

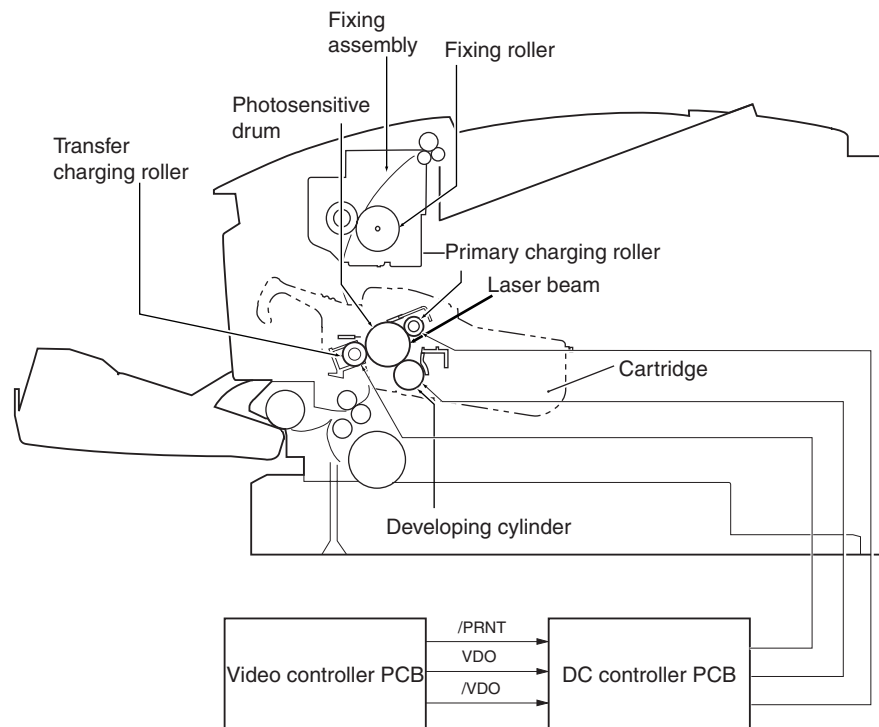

Figure 2-4-1

B. Printing Process

As shown in the diagram, the principal area of the image formation system is found inside the cartridge:

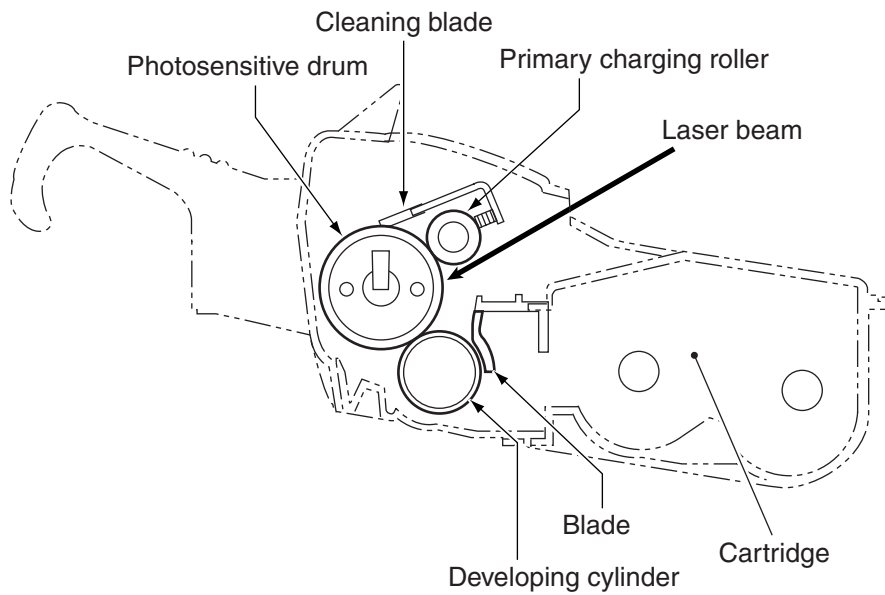

Figure 2-4-2

The Printer uses a 2-layer seamless drum; the outer coating is a photo conducting laser made of optical photoconduction (OPC) material, while the inner coating is an aluminum substrate.

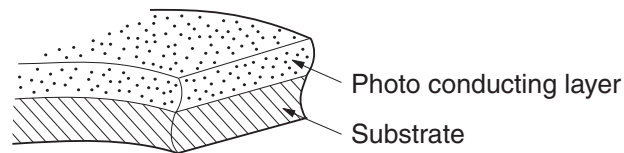

Figure 2-4-3

The printing process broadly consists of the following 5 blocks (7 steps):

(1) Latent static Image Formation Block

- Step 1: primary charging (-)
- Step 2: laser beam exposure

(2) Development Block

- Step 3: development

(3) Transfer Block

- Step 4: transfer (+)
- Step 5: separation (grounding)

(4) Fixing Block

- Step 6: fixing

(5) Drum Cleaning Block

- Step 7; drum cleaning

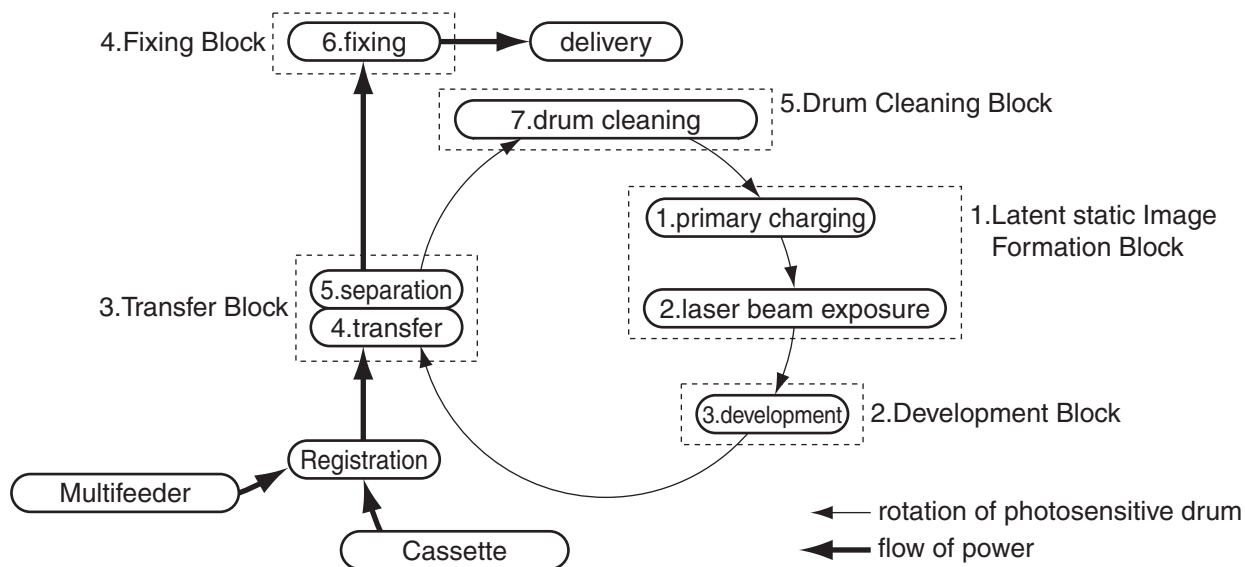

Figure 2-4-4

1. Latent static image formation block

This block consists of 2 steps, and is used to form a latent static image on the photosensitive drum.

At the end of the last step of this block, the area of the surface of the photosensitive drum not exposed by the laser beam (dark area) will retain negative charges, while the area on the surface of the photosensitive drum exposed by the laser beam (light area) will be free of negative charges.

The drum image formed by negative charges is not visible to the human eye, and is therefore called a 'latent static image.'

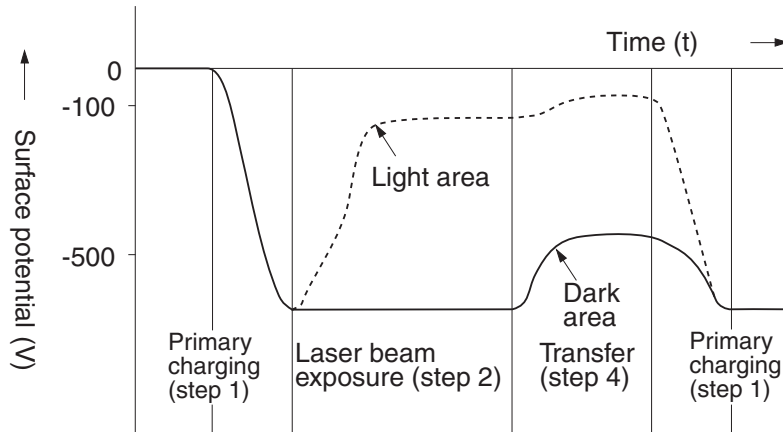

Figure 2-4-5

Step 1: primary charging

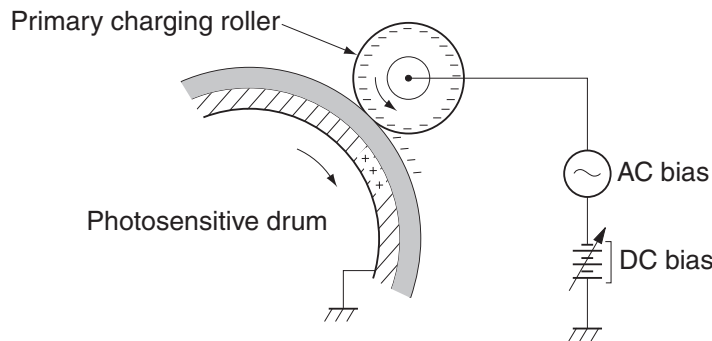
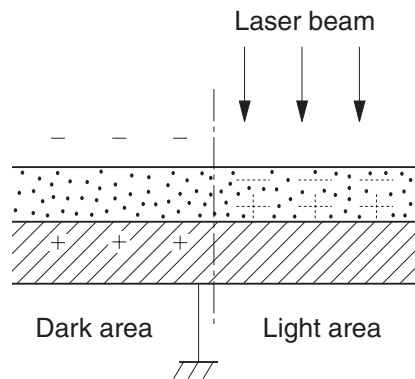

Figure 2-4-6

To prepare for the formation of a latent image, the surface of the photosensitive drum is charged to a uniform, negative potential.

The Printer uses a method of primary charging in which charges are applied directly to the surface of the photosensitive drum.

The primary charging roller is made of conducting rubber. To ensure that the surface potential occurring on the photosensitive drum is uniform, an AC bias is applied to the primary charging roller in addition to an DC bias. The DC bias is controlled so that it varies in keeping with the developing DC bias.

Step 2: laser beam exposure**Figure 2-4-7**

When the laser beam is run across the photosensitive drum, the charges in the light area become neutralized, forming a latent static image.

2. Developing block

In this block, toner is deposited to cover the latent static image on the surface of the photosensitive drum, thus turning it into a visible image.

The Printer uses a toner projection development method, and its toner is a 1-component type.

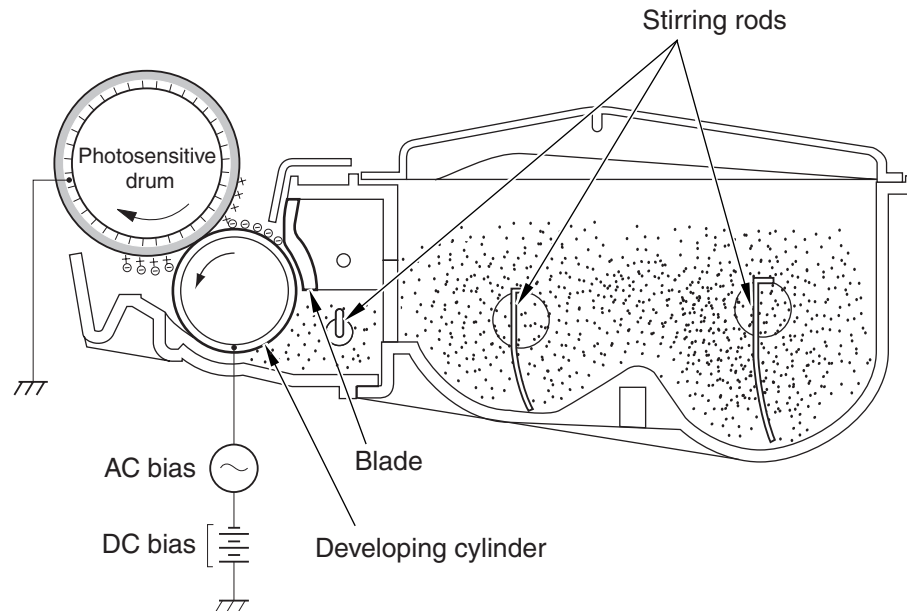
Step 3: development**Figure 2-4-8**

Note: The light area of the surface of the photosensitive drum actually carries a negative potential, but the diagram expresses it as carrying a positive potential. The fact indicates that the potential of the photosensitive drum is higher than that of the cylinder when the latter is used as the point of reference.

As can be learned from the diagram, the developing assembly consists of a fixed magnet, a developing cylinder that rotates around the magnet, and a rubber blade.

The developer is called toner, and the Printer uses a 1-component type; it is composed of magnetite and resins, and is retained on the cylinder by a magnetic force. The toner has insulating characteristics, and is charged to a negative potential by friction against the rotation cylinder.

The area of the photosensitive drum exposed by the laser beam has a potential higher than that of the toner negatively charged on the cylinder. When the area comes closer to the toner layer (possessing a negative potential) on the cylinder, the difference in potential between the surface of the photosensitive drum and the cylinder will cause the toner to jump to and stick to the surface of the photosensitive drum. This is referred to as 'toner projection,' and is used to turn the latent static image on the surface of the photosensitive drum into a visible image.

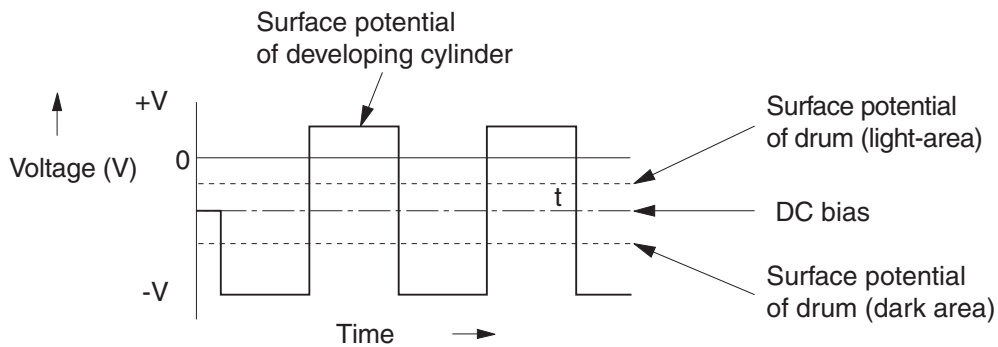

Figure 2-4-9

To facilitate the projection of toner to the photosensitive drum and also to enhance the contrast in output images, an AC bias is applied to the developing cylinder.

The median voltage of the AC bias (1600 Vp-p) varies in relation to the voltage of the DC bias. Varying the DC bias, the difference in potential between the cylinder and the photosensitive drum is adjusted to control the density of printed images (as in response to commands from an external device).

The Printer is also equipped with a stirring mechanism to ensure smooth supply of toner from the toner case to the cylinder.

3. Transfer block

This block is used to transfer the toner image on the surface of the photosensitive drum to paper.

Step 4: transfer

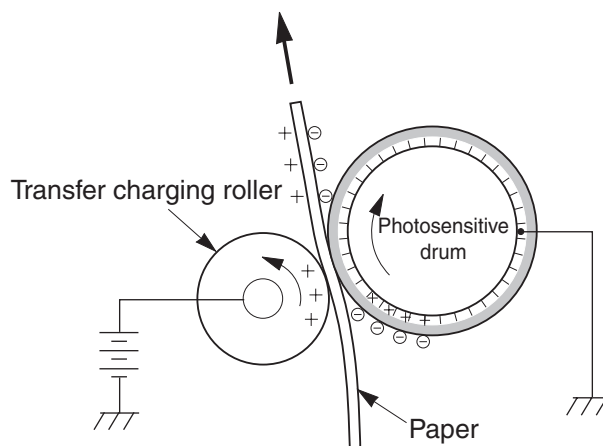

Figure 2-4-10

Positive charges are applied to the back of paper to draw toner to the face of the paper from the photosensitive drum. A roller transfer method is used, which allows smooth movement of paper and reduction of generated ozone.

Step 5: separation

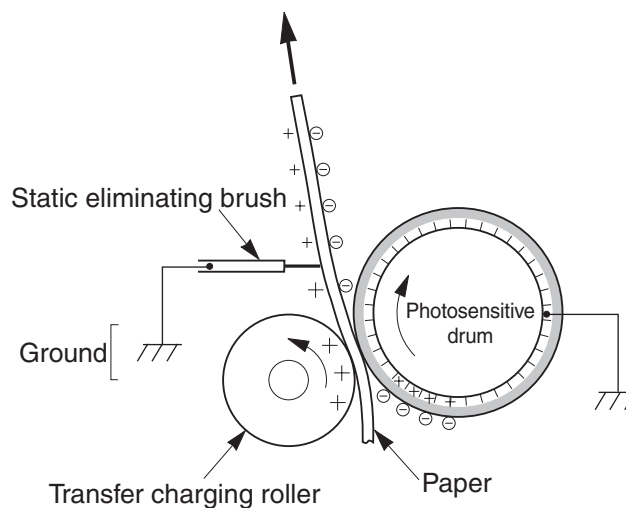

Figure 2-4-11

The rigidity of paper is used to separate paper from the photosensitive drum.

The static eliminating brush is used to prevent the toner image from flying astray in dots when paper is separated (by separation static charges); i.e., the static eliminating brush attenuates the charges on the back of the paper.

4. Fixing block

The toner on the paper from the transfer block is retained on the paper by the work of static charges, and can move astray in response to the lightest impact (as when touched by the hand).

The toner and the paper are thus subjected to pressure and heat, thereby fusing the toner with the fibers of the paper and, ultimately, making the image permanent.

Step 6: fixing

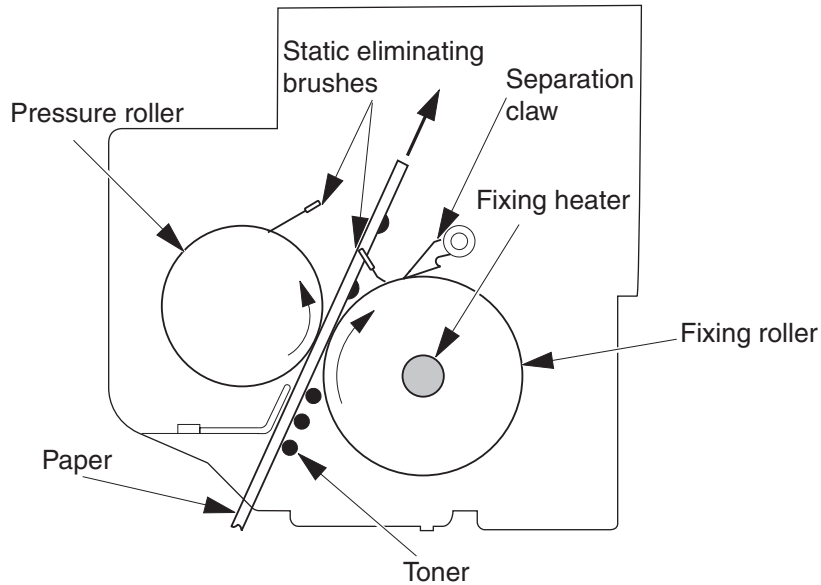

Figure 2-4-12

The surface of the fixing roller is coated with fluorine, and the static brush is grounded to prevent offset. The separation claws are used to ensure full separation of paper.

5. Drum cleaning block

In the transfer step, not all toner on the photosensitive drum is transferred to the paper, with some being left behind.

The drum cleaning block is used to clean the surface of the photosensitive drum, thereby ensuring the reproduction of sharp images for the next run.

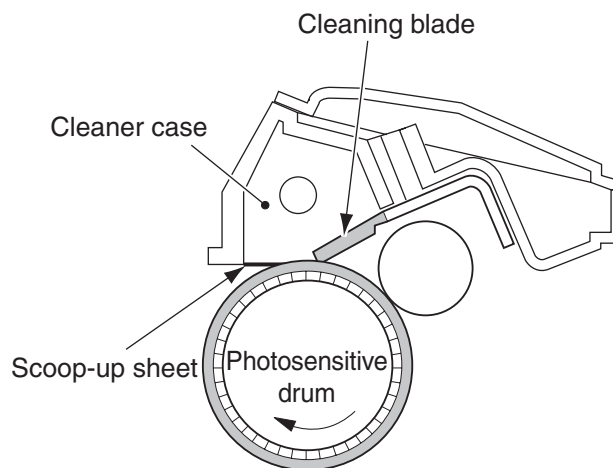

Figure 2-4-13

In preparation for the next run, the cleaning blade is used to scrape off the toner remaining on the surface of the photosensitive drum for cleaning. The scraped toner is then collected inside the cleaner case of the cartridge.

V. PICKUP/FEEDING SYSTEM

A. Outline

The presence/absence of paper in the multifeeder tray is detected by the multifeeder tray paper sensor (PI102), and the presence/absence of paper in the cassette is detected by the cassette paper sensor (PI104).

The size of paper inside the cassette set in the Printer and the presence/absence of the cassette are checked by the paper size detecting switch (SW105) inside the Printer.

When the cassette is used as the source of paper, the cassette pickup clutch (CL101) goes on while the main motor is rotating, causing the cassette pickup roller to rotate to feed a sheet of paper.

When the multifeeder tray is used, the multifeeder pickup solenoid (SL101) goes on while the main motor is rotating, causing the manual feed pickup roller to rotate to feed a single sheet of paper.

When the paper moves past the registration paper sensor (PI101) and reaches the registration roller, it is stopped and is made to arch on its leading edge, thus ridding itself of any skew. Thereafter, the registration clutch (CL102) goes on to move the paper farther.

A specific period of time after the registration paper sensor (PI101) goes on (as set by the leading edge registration adjusting volume VR101 on the DC controller), the vertical sync signal (/TOP) is sent by the DC controller to the video controller.

A specific period of time after the video controller receives the /TOP signal, video signals (/VDO, VDO) are sent, and the leading edge of the paper is matched against the leading edge of the image on the surface of the photosensitive drum. Thereafter, the paper is moved through the transfer, separation, and fixing blocks for face-down delivery.

The paper path is equipped with 2 photointerrupters (PI101, PI103) to monitor the arrival or passage of paper. If the paper fails to reach or move past either of these sensors within a specific period of time, the microprocessor (CPU) on the DC controller will identify the condition as indicating a jam, and will inform the video controller of the presence of a jam.

The following diagram shows the arrangement of the rollers and the sensors used in the pickup/feeding system:

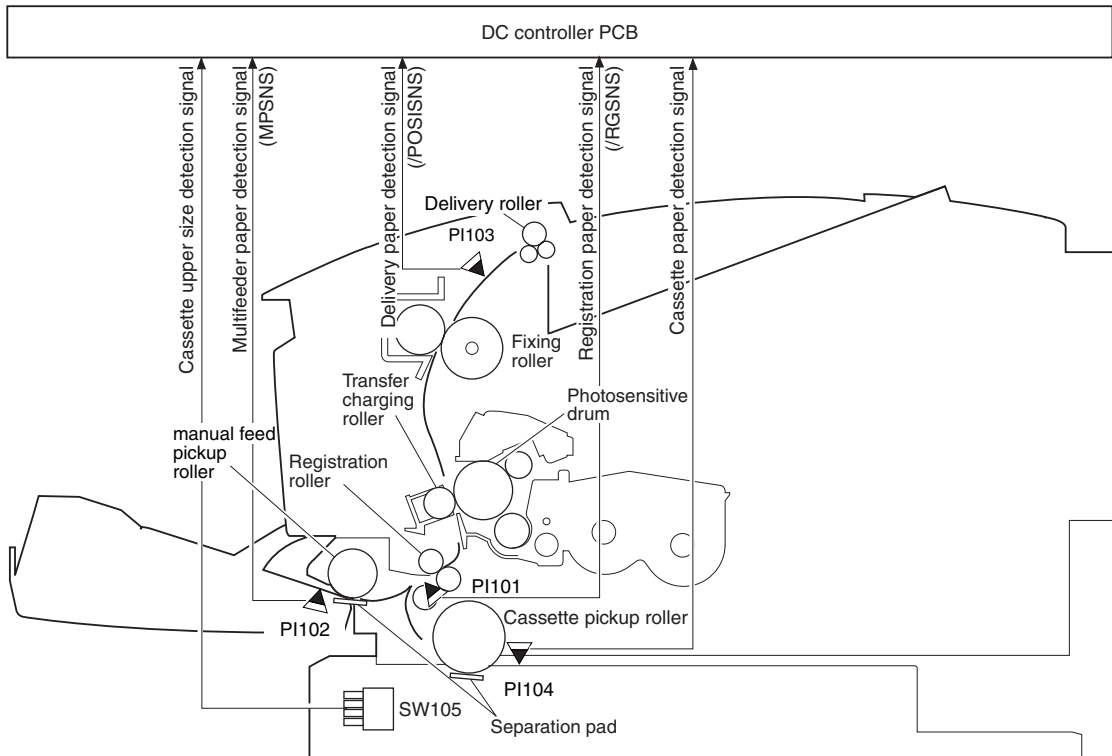

Figure 2-5-1

- PI101: registration paper sensors
- PI102: multifeeder paper sensor
- PI103: delivery sensor
- PI104: cassette paper sensor
- SW105:cassette paper size detecting switch

The following diagram gives an outline of operation:

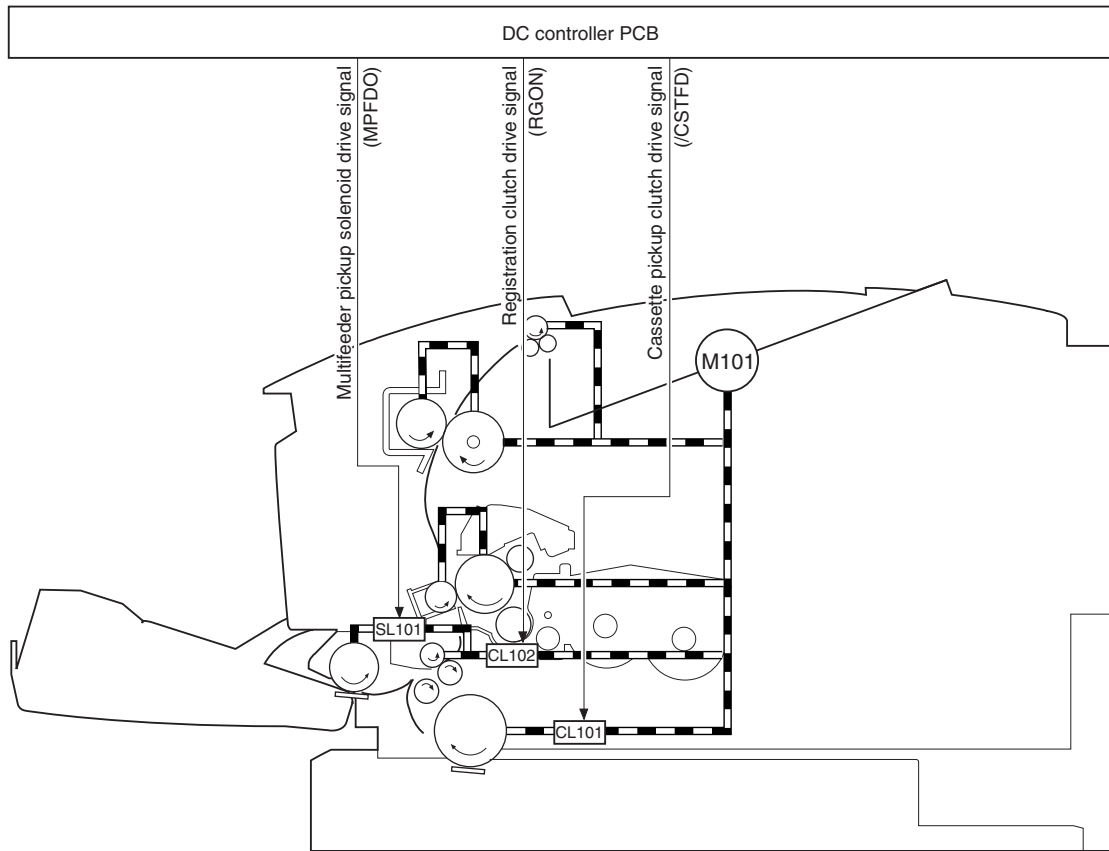

Figure 2-5-2

- SL101: multifeeder pickup solenoid
- CL101: multifeeder pickup clutch
- CL102: registration clutch
- M101: main motor

B. Detecting the Paper Size

1. Detecting the size of paper in the cassette

When the cassette is set in the Printer, specific switches are turned on: combinations of the states of the following switches are used by the CPU to detect the size of paper inside the cassette or the presence/absence of the cassette:

Table 2-5-1

Paper size	Paper size detecting switch			
	PSSN4 (leftmost)	PSSN3 (middle left)	PSSN2 (middle right)	PSSN1 (rightmost)
A3	ON	OFF	OFF	OFF
A4R	OFF	OFF	ON	ON
A4	OFF	OFF	OFF	ON
A5	OFF	ON	ON	ON
B4	OFF	ON	ON	OFF
B5	ON	ON	OFF	OFF
11 x 17	OFF	ON	OFF	ON
LGL	ON	OFF	ON	ON
LTR	ON	ON	OFF	ON
EXEC	ON	OFF	ON	OFF
No cassette	Other than above			

To prevent a mistake in the selection of a paper size by the user, the Printer is designed to measure the time between when the registration paper sensor (PI101) detects the leading edge of paper and when the trailing edge of the paper leaves it. If the measurement does not correspond to the paper size found based on a combination of the states of the switches indicated in the table or if it is different from the length selected by the video controller for the paper placed in the multifeder tray by ± 10 mm, the CPU will identify a size mismatch condition and communicate the fact to the video controller.

2. Detecting the size of the paper in the multifeder tray

As in the case of the cassette, the multifeder tray uses the registration paper sensor (PI101) to find out the size of paper. However, a mismatch in size cannot be detected for A4R (vertical)/LTR-R (vertical) or B5/Executive-R (vertical) because of limited paper length.

When Universal is selected for the size, detection for a mismatch in size will not be executed.

C. Using the Cassette

1. Outline

When the video controller sends the /PRNT signal to the Printer, the CPU rotates the main motor (M101); in about 0.15 sec, it turns on the pickup clutch (CL101) to transmit the rotation of the main motor to rotate the cassette pickup roller.

A single sheet of paper is then fed inside by the rotation of the cassette pickup roller. The paper moves past the registration paper sensor (PI101) to reach the registration roller. At this time, the registration roller is not rotating so that the paper stops, and arches along its leading edge for correction of any skew. The pickup clutch (CL101) is turned off as soon as the paper arches to stop the rotation of the cassette pickup roller. At the same time, the registration clutch (CL102) is turned on to move the paper once again for the transfer, separation, and fixing blocks.

• **Paper Path for Cassette Pickup**

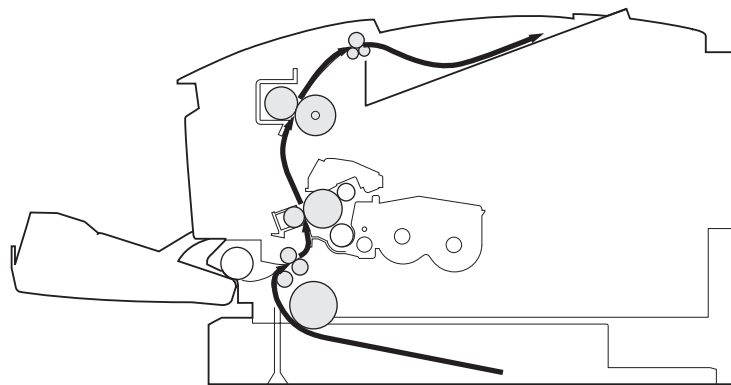

Figure 2-5-3

• **Basic Sequence of Operation for Cassette Pickup**

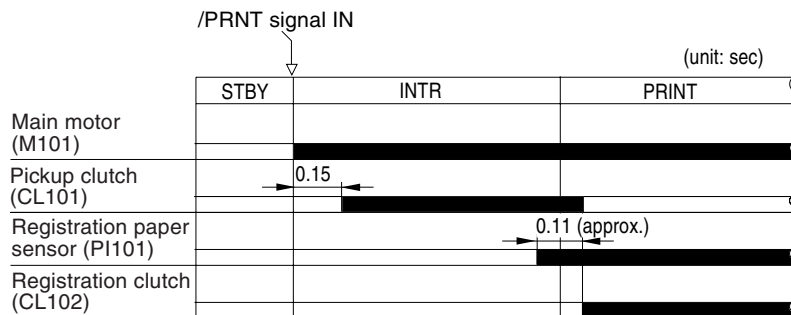

Figure 2-5-4

2. Retry control

When the cassette is used as the source of paper, the cassette pickup roller is kept in contact with the stack of paper at all times. As such, the Printer does not perform pickup retry control, but prevents the occurrence of pickup delay jams by delaying the timing at which the pickup clutch (CL101) is turned on.

D. Using the Multifeeder

1. Outline

The presence/absence of paper in the multifeeder tray is detected by the multifeeder paper sensor (PI102).

When the /PRNT signal arrives from the video controller, the CPU rotates the main motor (M101) and the scanner motor (M102), and then turns on the multifeeder solenoid (SL101) as soon as the Printer is ready for printing.

As a result, the cam starts to rotate and the holding plate (on which paper is laid) starts to move up to put the paper in contact with the multifeeder pickup roller. At the same time, the manual feed pickup roller makes a single rotation, thus feeding a single sheet of paper from the multifeeder.

The paper then moves past the registration paper sensor (PI101) and reaches the registration roller. At this time, the registration roller is not rotating, and the paper stops to arch along its leading edge, thus removing any skew. The CPU turns on the registration clutch (CL102) as soon as the paper arches so that the paper moves farther for the transfer, separation, and fixing blocks for face-down delivery.

- **Paper Path for Multifeeder Tray Pickup**

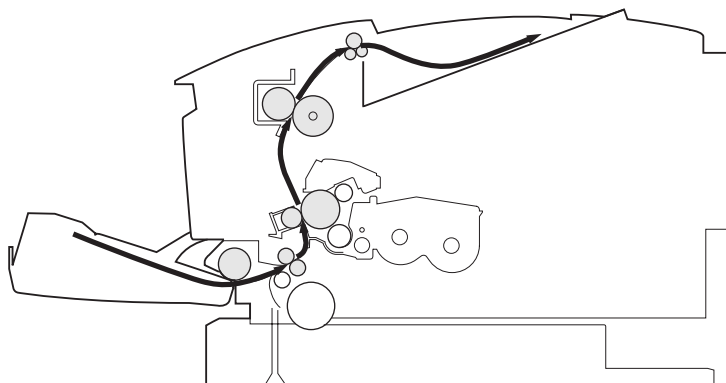

Figure 2-5-5

• **Multifeeder Tray Pickup Operation**

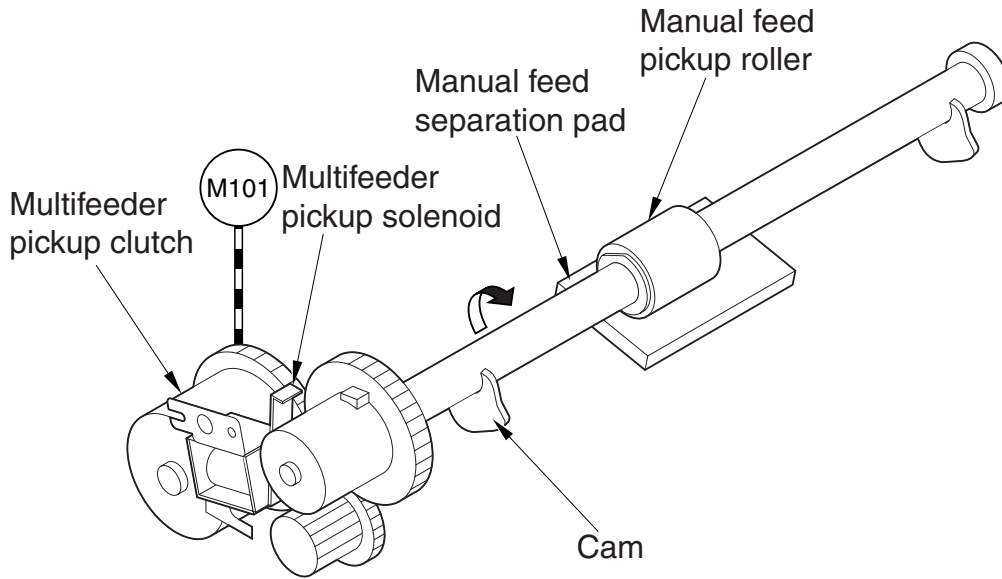

Figure 2-5-6

• **Basic Sequence of Operation for Multifeeder Tray Pickup**

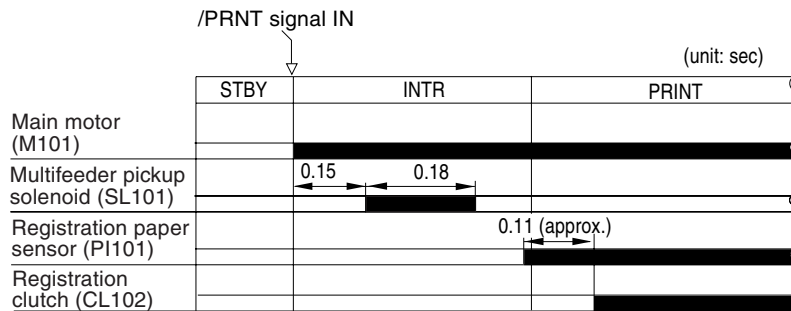

Figure 2-5-7

2. Retry control

The Printer executes pickup retry control if paper fails to reach the registration paper sensor (PI101) in about 0.88 sec after the multifeeder pickup solenoid (SL101) goes on because of wear on the roller or a pickup fault.

The multifeeder pickup solenoid (SL101) goes on pick up retry control for a second time.

The retry sequence is as follows:

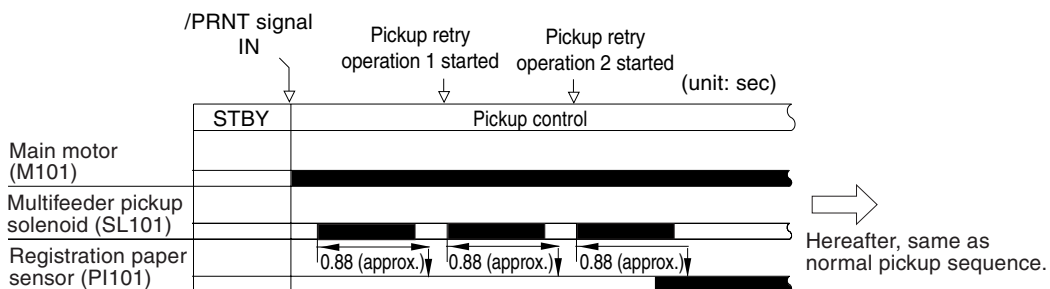

Figure 2-5-8

E. Fixing/Delivery Assembly

The pressure roller and the delivery roller of the fixing assembly are driven by the main motor (M101).

The paper separated from the photosensitive drum is moved to the inside of the fixing assembly, and the toner is fused to its fibers by the work of the fixing roller; the paper is then moved outside the fixing assembly.

The paper is detected by the delivery sensor (PI103), and is then delivered (face-down).

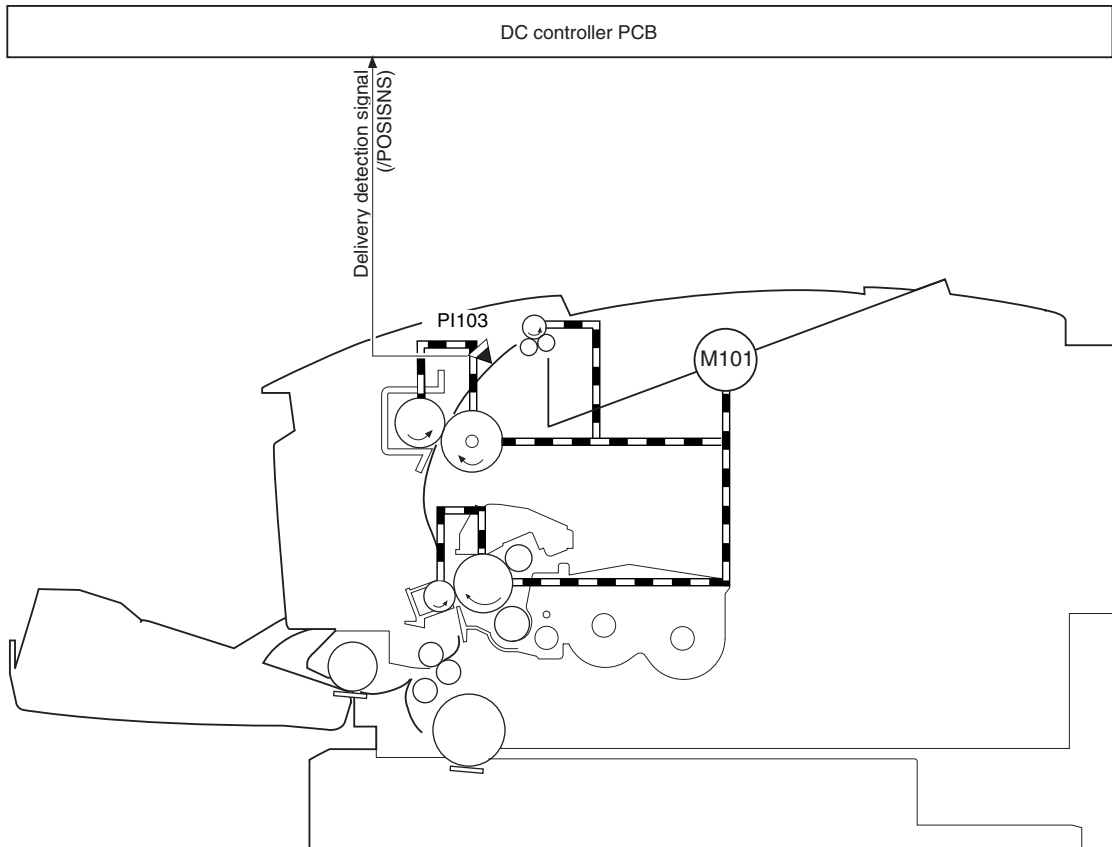

Figure 2-5-9

F. Detecting Jams

1. Outline

The following paper sensor are used to monitor the movement of paper inside the Printer:

- Registration paper sensor (PI101)
- Delivery sensor (PI103)

The presence of a jam is checked at such times as instructed by the program stored in advance in the CPU in relation to the presence/absence of paper at a specific sensor. When the CPU detects a jam, it will stop printing operation and communicate the presence of a jam to the video controller.

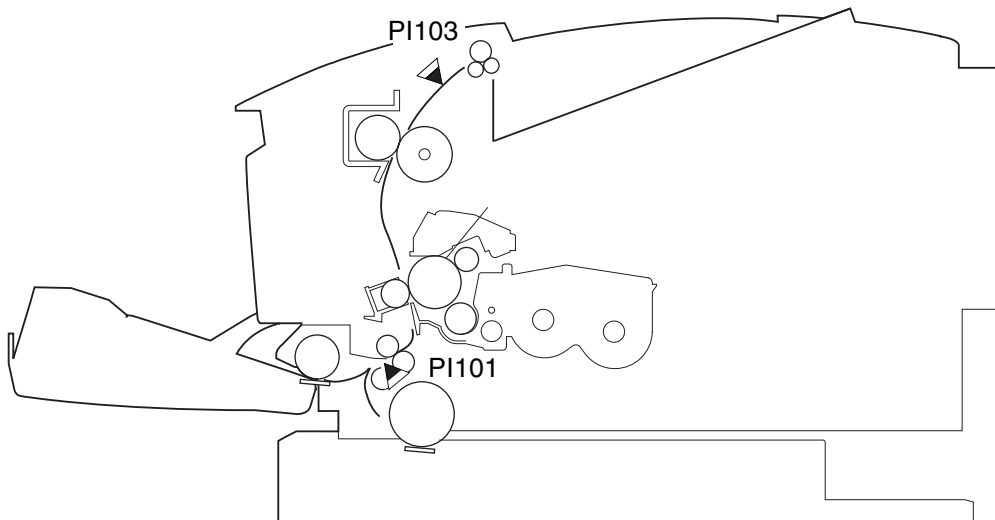

Figure 2-5-10

2. Pickup jams

a. Pickup delay jam

When the cassette is used as the source of paper, a jam will be identified if the registration paper sensor (PI101) does not detect the leading edge of paper within a specific period of time after the start of pickup. Inside the cassette, the cassette pickup roller remains in contact with the paper at all times; for this reason, pickup retry control will not be executed, but a longer jam detection margin is used.

When the multifeder tray is used as the source of paper, pickup retry control will be executed twice (max.) if the registration paper sensor (PI101) does not detect the leading edge of paper within a specific period of time after the start of pickup.

If the registration paper sensor (PI101) still does not detect the leading edge of paper, the condition will be identified as a jam, and a message to this effect will be indicated on the LCD in the control panel.

- Sequence for a Pickup Delay Jam (cassette)

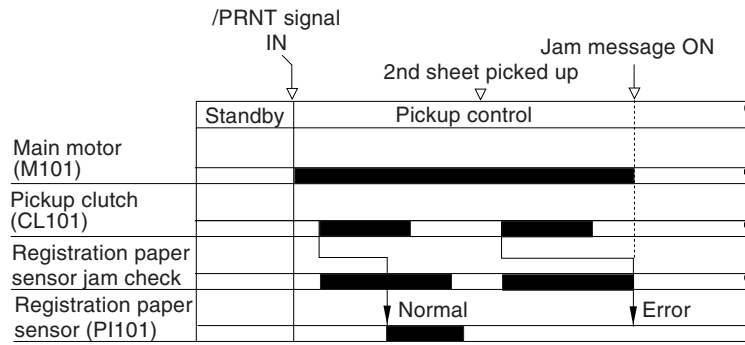

Figure 2-5-11

- Sequence for a Pickup Delay Jam (multifeeder tray)

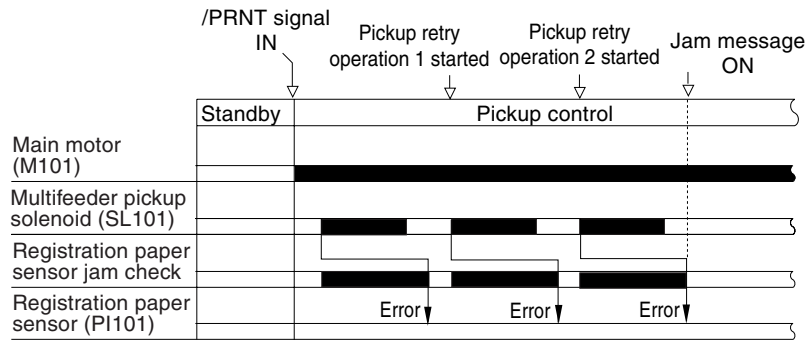

Figure 2-5-12

b. Stationary jam

A jam will be detected if the registration paper sensor (PI101) detects the absence of paper (trailing edge of the previous sheet) by the time the leading edge of paper reaches the registration paper sensor.

In the case of the last sheet when printing a single page or in continuous mode, if the registration paper sensor (PI101) does not detect the trailing edge of paper within a specific period of time after the registration clutch (CL102) is turned on, the CPU will identify the condition as a jam; it will then stop printing operation and indicate the presence of a jam to the video controller.

• **Sequence for a Registration Stationary Jam**

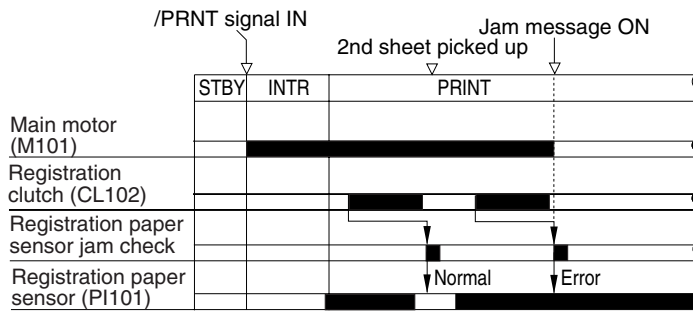

Figure 2-5-13

• **Sequence for a Registration Sensor Pickup Stationary Jam (last sheet)**
Normal

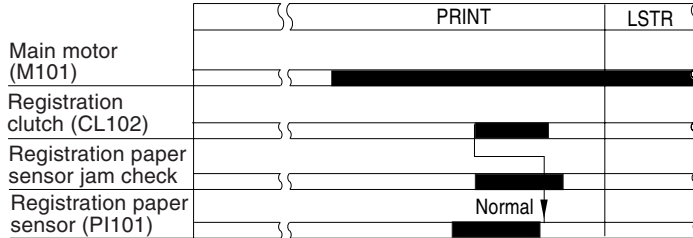

Figure 2-5-14

Error

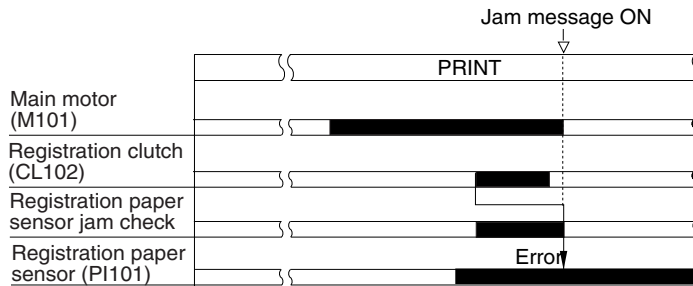

Figure 2-5-15

3. Delivery jams

a. Delivery assembly delay jam

A delivery leading edge delay jam or the fixing assembly wrap jam will be identified by the DC controller as a delivery assembly delay jam.

When the CPU on the DC controller detects the presence of a jam, it will stop printing operation and indicates the fact to the video controller.

- **Delivery Leading Edge Delay Jam**

The delivery sensor (PI103) does not detect the leading edge of paper within a specific period of time after the registration roller starts to rotate to move paper.

- **Fixing Assembly Wrap Jam**

The delivery sensor detects the absence of paper before a specific period of time has passed after it detects the leading edge of paper moved by the registration roller.

However, if the paper is 98 mm or less in length, the detection of a fixing assembly wrap jam will not be executed.

- **Sequence for a Delivery Sensor Leading Edge Delay Jam**

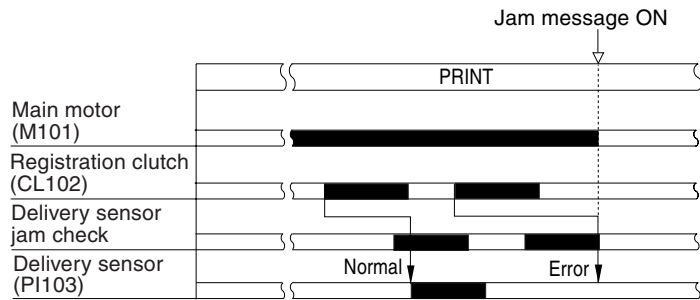

Figure 2-5-16

- **Sequence for a Fixing Assembly Wrap Jam**

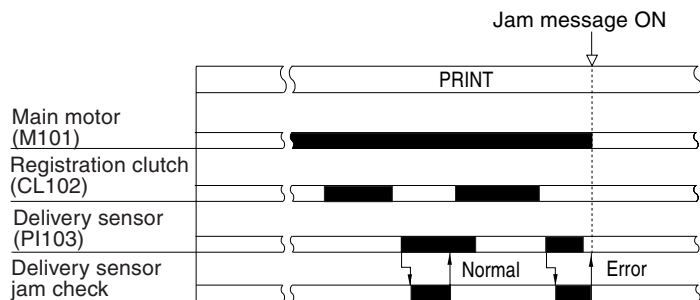

Figure 2-5-17

b. Delivery assembly stationary jam

A delivery trailing edge delivery jam or a delivery stationary jam is identified by the DC controller as a delivery assembly stationary jam.

When the CPU on the DC controller PCB detects a jam, it will stop printing operation and indicates the fact to the video controller.

- **Delivery Trailing Edge Delay Jam**

The delivery sensor (PI103) does not detect the absence of paper within a specific period of time after the registration paper sensor goes off.

- **Delivery Sensor (PI103) Stationary Jam**

When printing is started from standby, the delivery sensor (PI103) does not detect the absence of paper with a specific period of time after it detects the leading edge of paper.

- **Sequence for a Delivery Trailing Edge Delay Jam**

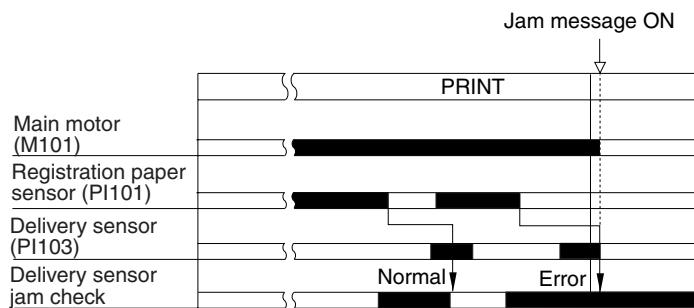

Figure 2-5-18

- **Sequence for a Delivery Stationery Jam**

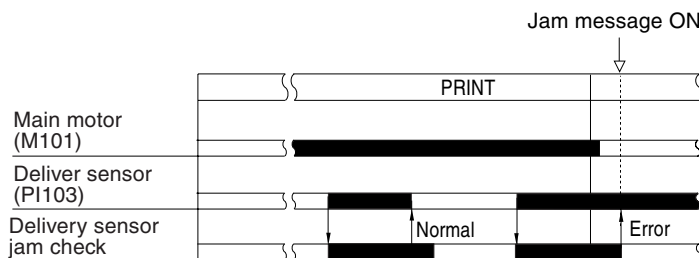

Figure 2-5-19

4. Other jams

a. Residual jam

If the delivery sensor (PI103) detects the presence of paper within 1.4 sec after the start of initial rotation (INTR), or if the registration sensor (PI102) detects the presence of paper at the start of initial rotation (INTR), the DC controller will identify the condition as a residual jam.

When the CPU on the DC controller PCB detects a jam, it will stop printing operation and indicate the presence of a jam to the video controller.

b. Front cover open jam

If the front cover is opened while paper is in the paper path, the DC controller will identify the condition as a front cover open jam.

When the CPU on the DC controller PCB identifies a jam, it will stop the printing operation and indicate the presence of a jam to the video controller.

VI. VIDEO CONTROL SYSTEM

A. Outline of the Electrical Curcuitry

1. Outline

This circuit is designed to receive print data consisting of code data or image data from an external device (e.g., host computer) through an interface cable.

The circuit processes the print data it has received based on the instructions from the control panel for conversion into dot data.

The resulting dot data is then converted into video signals, which are sent to the DC controller for control of the laser diode.

The arrangement used in the circuit is shown in Figure 2-6-1, and its block diagram is given as Figure 2-6-2.

2. Outline of the operation of each block

a. CPU

The CPU is a 64-bit RISC microprocessor. It has a circuit construction suited to the control of an LBP, and controls the operation of the Printer according to the program stored in ROM. Its main functions are as follows:

1. controlling the SDRAM
2. controlling the ROM
3. controlling the video controller interface, HDD interface, and expansion interface
4. communicating with the engine
5. controlling the IEEE 1284 parallel port interface
6. controlling the compression/expansion of image data

b. ASIC

The ASIC is used to control the operation of the video controller circuit according to the control program stored in ROM. Its main functions are as follows:

1. controlling of image smoothing operation
2. controlling the EEPROM
3. controlling the option panel interface

c. DRAM

The DRAM possesses 4 M of memory, and stores the following data items:

1. print data from external devices (reception buffer)
2. pattern data resulting from conversion of code data or image data
3. fonts processed by the video controller

A slot for expansion is also provided, enabling expansion to as much as 72 MB by fitting an expansion RAM DIMM (32 M or 64 M) into the slot found on the video controller PCB.

d. Built-In Program ROM

The built-in program ROM possesses 8 MB of memory, and stores data for operation sequence control by the video controller circuit and residual fonts.

e. Expansion ROM DIMM (J1, J2, J3)

The expansion ROM DIMM may be enhanced by a ROM DIMM for upgrading, Font ROM DIMM as an option, and Flash ROM DIMM; as many as 3 pieces may be installed, and any slot may be used for installation.

f. EEPROM (IC4, IC5)

It possesses 32K bits of memory, and it allows erasing and writing of data. It is used to retain data (various settings; printing environment, number of pages) after power is turned off.

g. Program ROM version up

When installing a ROM DIMM for version up to the slot (J1/J2/J3), the functions of the mounted built-in program ROM will be stopped and its contents will be replaced by the contents held in the newly installed ROM DIMM. (You need not remove the built-in program ROM.)

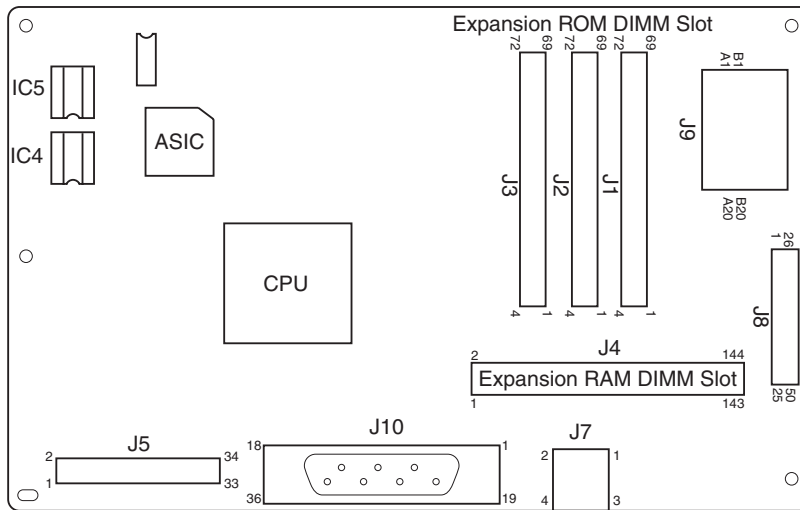

Figure 2-6-1

The following is a block diagram of the video controller circuit:

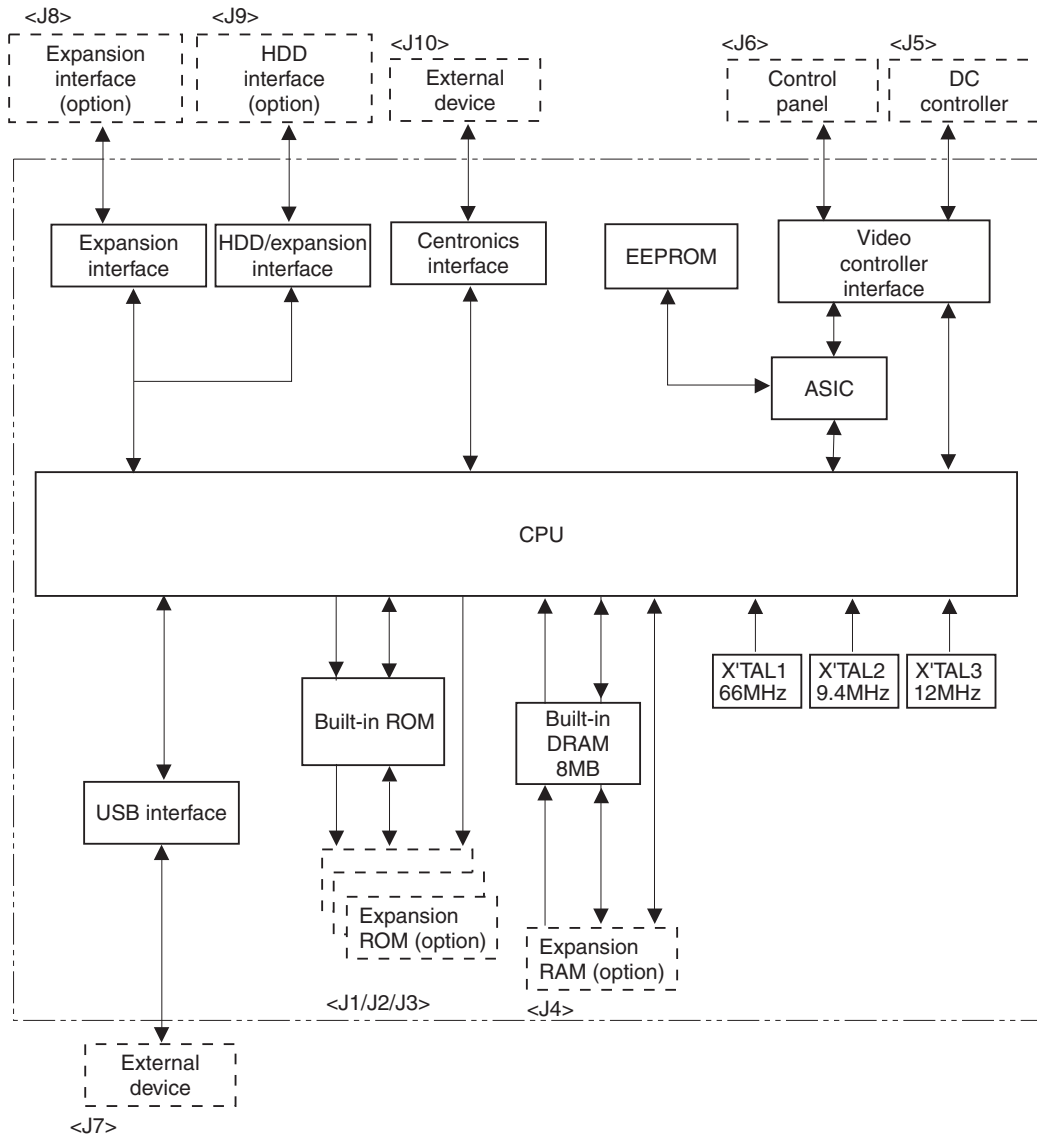

Figure 2-6-2

B. Operation Panel

1. Outline

The operation panel has one LCD with 16 characters by 2 lines, six switches, and four LEDs.

The operation panel is connected with the video controller PCB and has the following functions.

- a. Displays status and error message on the LCD.
- b. Displays condition of the operation on the LED.
- c. Changes menu to activate and the set values with the switches.

2. Operation

The LCD and LEDs on the operation panel are controlled by the signal output from the video controller. Any signals indicated by the switches on the operation panel are input to the video controller.

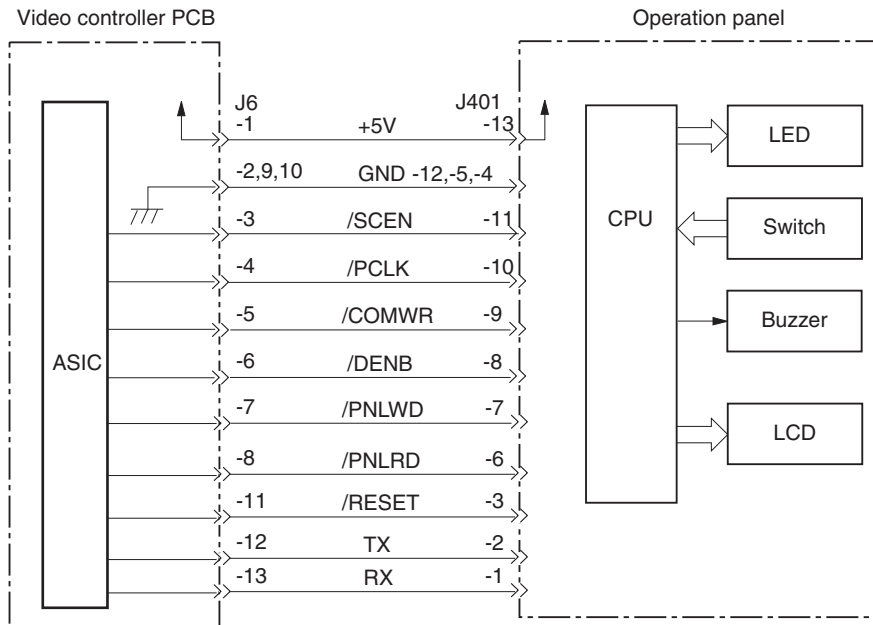

Figure 2-6-3

C. Self Test

The printer has the function to check the condition of the video controller by executing the self diagnosis program of the video controller. This is called 'self-test' Self-test has two kinds of test; power ON self test and power ON key sequence.

1. Power ON self test

The power ON self test is executed following the procedures stated below every time the printer is switched ON.

- 1) Tests the DRAM on the video controller. The error message is displayed on the LCD if any error occurred.
- 2) Tests all program ROM, font ROM, and option ROM. The error message is displayed on the LCD if any error occurred.
- 3) Tests inside of the CPU. The error message is displayed on the LCD if any error occurred.
- 4) Ends the self-test. The error is displayed on the operation panel if it is notified from the engine controller.
- 5) After the completion of the self-test, the 'READY' message is displayed on the operation panel, then PCL demo-page is printed automatically.

2. Power ON key sequence

By pressing the specified keys simultaneously when turning the power ON, the specific function can be executed.

a. Check sum functions

Turn the power ON while pressing the GO and Shift keys simultaneously (PPG Check Sum: ROM bank 0) or GO and Value keys simultaneously (PS Check Sum: ROM bank 1).

The printer performs the check sum on the requested ROM bank with this function. The calculated Check Sum is displayed on the LCD.

b. Factory reset function (A4/LTR)

To reset the paper size default to A4, turn the power ON while pressing the Menu, Item, and Value keys simultaneously.

To reset the paper size default to Letter, turn the power ON while pressing the Item, Value, and Enter keys simultaneously.

The printer sets the default to the selected paper size (A4/LTR) with the function, resets it to zero, if the page count is less than fifty counts.

c. Panel check function

The printer executes the operation panel diagnosis and the test sequence with the panel check function. The Function has following sequences.

- 1) The printer is powered ON with Go and Enter keys both pressed, causing the 'PANEL CHECK' message to be displayed on the LCD.
- 2) Steps 3 through 8 below may be invoked in any order and/or multiple times.
- 3) If the Go key is pressed, the OnLine LED is lit and the 'OPERATION CHECK' message is displayed.
Releasing the key clears the LED and the message.
- 4) If the Shift key is pressed, the Job LED is lit and the 'OPERATION CHECK' message is displayed.
Releasing the key clears the LED and the message.
- 5) If the Menu key is pressed, the Alarm LED is lit and the 'OPERATION CHECK' message is displayed. Releasing the key clears the LED and the message.
- 6) If the Item key is pressed, all the LEDs are lit and the left half of the LCD (8 columns/both rows) is illuminated. Releasing the key clears the LEDs and the display.

- 7) If the Value key is pressed, all the LEDs are lit and the right half of the LCD (8 columns/both rows) is illuminated. Releasing the key clears the LEDs and the display.
- 8) If the Enter key is pressed, all the LEDs are lit and all the columns of the LCD are illuminated (i.e. all the columns are blacked). Releasing the key clears the LEDs and the display.
- 9) When all the keys have been tested, 'PANEL CHECK DONE' message is displayed and all the LEDs are kept blinking. This state persists until the printer is turned OFF.

d. Update flash

Turn the power ON while pressing the Menu and Item keys simultaneously. This function provides a Flash Menu for managing and downloading firmware images.

Not that the function requires an expansion RAM DIMM as the total amount of RAM memory must be 8 Mbytes or more. If the Flash Menu is implemented with 4 Mbytes of memory (default value), the 'THE NOT ENOUGH DRAM TO PROCEED' message will be displayed.

e. Unformatted hard disk drive and flash rom dimm

1. During Power on if the Hard Disk Drive is read and writeable and does not have a High Level format the panel will display the following messages:
'+FORMAT DISK'
'-IGNORE FORMAT'
2. During Power on if the Add-on Flash Rom Dimm is not formatted the panel will display the following messages:
'+FORMAT FLASH'
'-IGNORE FLASH'

f. Service menu

The Service Menu is a hidden menu and contains the following sub menus;

1. ERR/JAM LOG MENU
2. FORMAT MENU
3. NVRAM MENU
4. PASSWORD MENU

The Service Menu is entered at power up by a sequence of two key presses. Each key press is a combination of 2 keys.

1. Press the 'Go' and 'Menu' key together and hold until the LCD displays WARMING UP.
2. Press the 'Menu', 'Value' and 'Enter' keys together and hold until SERVICE MENU is displayed, which should take about one second.
3. The service menu will become operational when the LCD changes to SERVICE MENU.
(See to VIII-C SERVICE MENU in Chapter 1)

VII. PAPER FEEDER

A. Outline

A paper feeder is used to pick up paper from any of the cassettes set inside, forwarding it to its host printer. As many as three paper feeders may be connected to the Printer: the first paper feeder will be referred to as PF1, while the second and third paper feeders are respectively referred to as PF2 and PF3.

The sequence of operation of a paper feeder is controlled by the paper feeder controller PCB, which is an 8-bit microprocessor. In addition to controlling the sequence of operation, the paper feeder controller PCB also controls communication with the (serial) DC controller PCB of the Printer.

The paper feeder controller PCB drives the motors and clutches in response to the various commands from the DC controller PCB, while keeping the Printer informed of what takes place in the paper feeder.

Figure 2-7-2 shows the flow of signals between paper feeder and Printer. The paper feeder is supplied by the host with +24 VDC and +5 VDC.

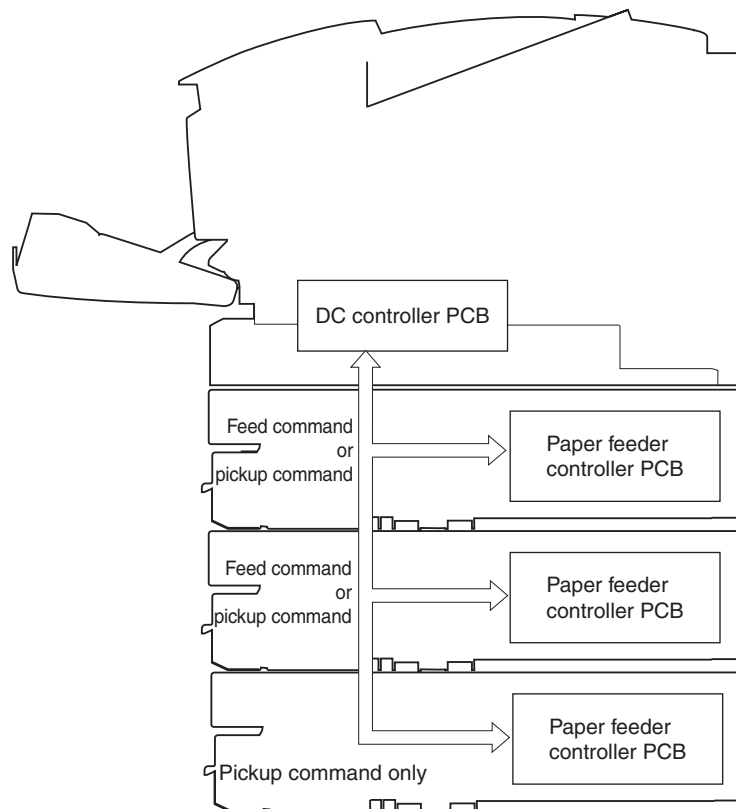

Figure 2-7-1

B. Inputs to and Outputs from the Paper Feeder Controller

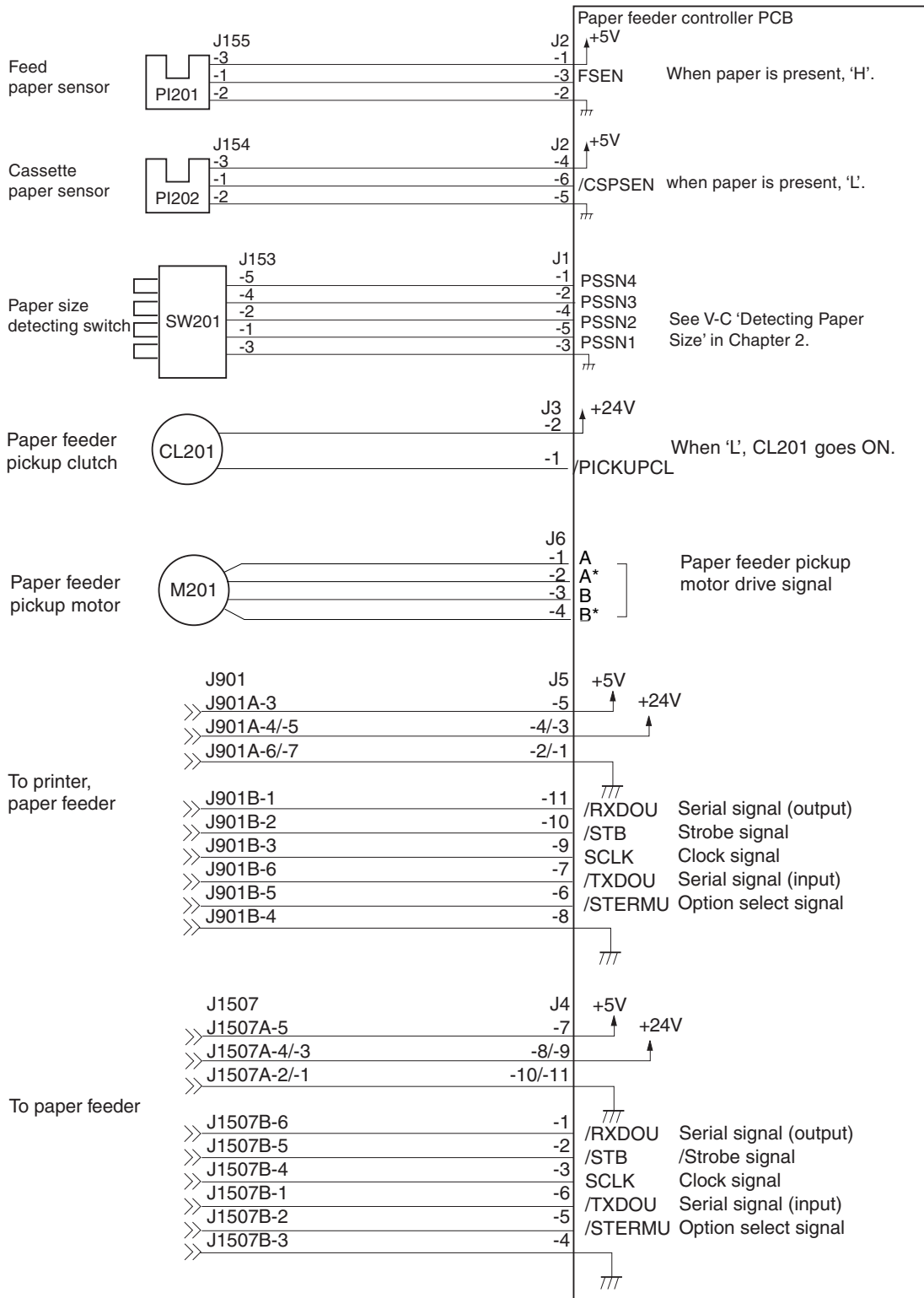

Figure 2-7-2

C. Pickup/Feeding Operation

1. Outline

The paper feeder pickup motor is a stepping motor, and its speed is controlled by the paper feeder controller PCB.

The paper feeder controller executes pickup operation or feeding operation in response to the pickup command or the feed command from the DC controller of the Printer.

In response to the pickup command, the paper feeder controller PCB drives the paper feeder pickup motor (M201) at high speed. The paper feeder pickup clutch (CL201) goes on at the same time, causing the paper feeder pick up roller to rotate to pick up paper from inside the cassette of the paper feeder.

The cassette separation pad makes sure that only a single sheet of paper is picked up, and the paper is moved by the feeding roller to the Printer or the next paper feeder in the paper path.

A specific period of time thereafter, the paper feeder controller PCB switches the speed of the paper feeder pickup motor so that it is the same as that of the Printer. The feeding roller as a result will start to rotate at the same speed as the Printer to move the paper.

If pickup occurs from the bottommost paper feeder as when multiple paper feeders are installed, the top paper feeder will be part of the paper path, requiring its feeding roller to rotate.

When the feed command is revised, the paper feeder controller PCB rotates the paper feeder pick up motor at high speed so that the feeding roller rotates to move the paper to the Printer. A specific period of time thereafter, the paper feeder controller PCB switches the speed of the paper feeder pickup motor to the speed of the Printer so that the feeding roller will start to rotate at the speed of the Printer to move the paper.

The paper path is equipped with a single photointerrupter used to monitor the arrival or passage of paper.

If paper fails to reach the sensor within a specific period of time or fails to move past it, the microprocessor (CPU) on the DC controller PCB of the Printer will identify the condition as indicating the presence of a jam, and will communicate the fact to the video controller.

The size of the cassette or the presence/absence of the cassette is detected as in the case of the Printer itself. (See V-B 'Detecting the Paper Size' in Chapter 2.)

The position of each cassette, on the other hand, is identified with reference to the machine inside communication signal (/TXDOU) and the options select signal (/STERMU), which are the input signals from the Printer's DC controller.

The Printer's DC controller sends the inside machine communication signal (/RXDOU) to find out the position of cassettes in relation to the number of options select signal (/STERMU), which is an output signal from the paper feeder controller PCB.

The following is an outline diagram of the drive mechanism:

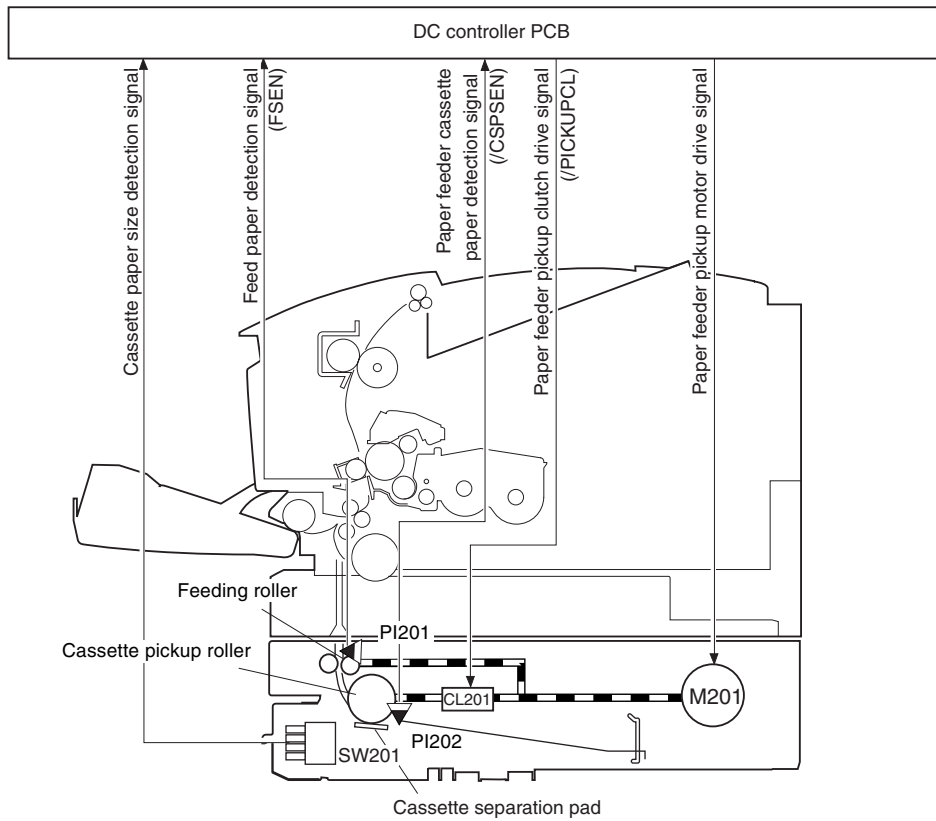

Figure 2-7-3

- PI201: paper feeder feed paper sensor
- PI202: paper feeder cassette paper sensor
- CL201: paper feeder pickup clutch
- M201: paper feeder pickup motor
- SW201: paper size detecting switch

Basic Sequence of Operation

- 3 paper feeders, pickup from bottommost; A4

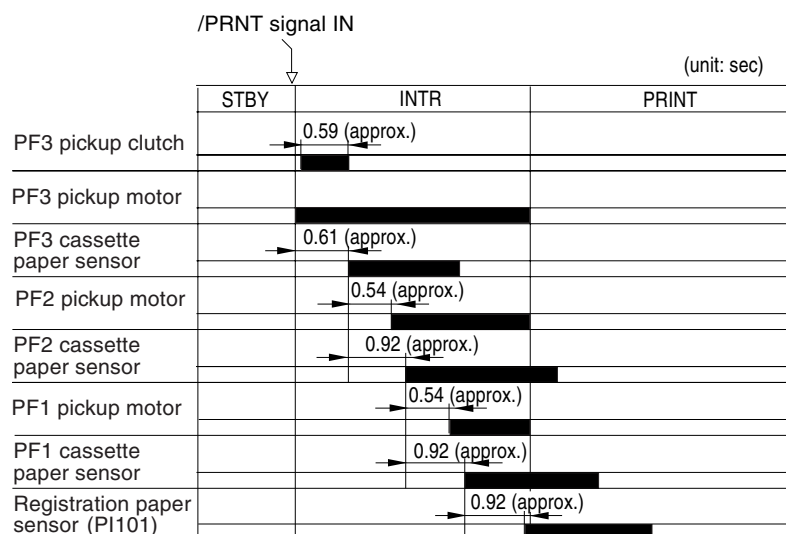

Figure 2-7-4

- 3 paper feeder, pickup from bottommost; A3

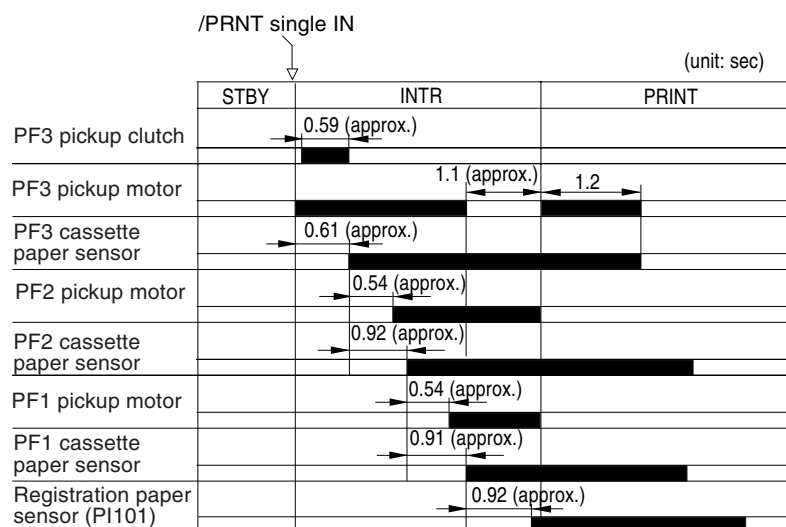

Figure 2-7-5

Note: If three paper feeders are used and, in addition, the bottommost is used for large-side paper, the leading edge of paper will not be able to leave the PF3 feeding roller after registration, possibly resulting in a registration stationary jam. To prevent this, the PF3 pickup motor is driven for 1.2 sec while moving the paper after registration to rotate the PF3 feeding roller.

D. Detecting Jams

The feed paper sensor (PI201) is used to check the presence/absence of paper and to find out if paper is moving correctly. It checks for a jam in terms of the presence/absence of paper over it at such times as programmed in advance. When the CPU detects a jam, it will stop printing operation and indicate the fact to the DC controller.

1. Pickup delay jam

The video controller will identify a feed sensor pickup delay jam or a registration sensor pickup delay jam as a pickup delay jam.

• **Feed Paper Sensor Pickup Delay Jam**

The feed paper sensor (PI201) does not detect the leading edge of paper within a specific period of time after the feeding roller starts to rotate to move paper.

• **Registration Paper Sensor Pickup Delay Jam**

The registration paper sensor (PI101) does not detect the leading edge of paper within a specific period of time after the feed sensor detects the leading edge of paper.

• **Feed Sensor Pickup Delay Jam**

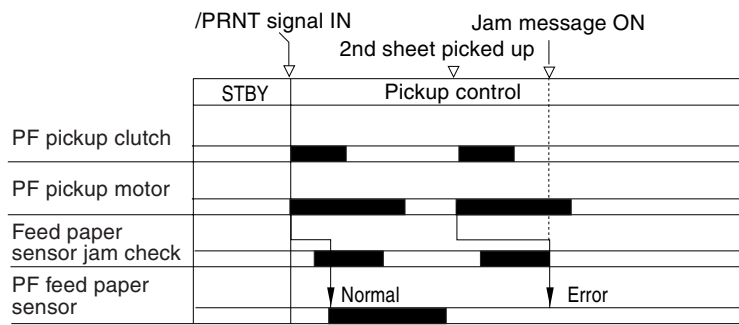

Figure 2-7-6

• **Registration Sensor Pickup Delay Jam**

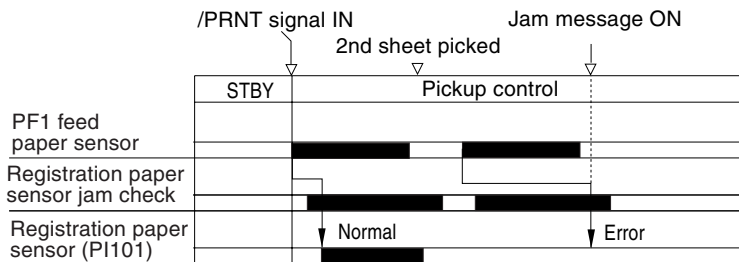

Figure 2-7-7

CHAPTER 3

MECHANICAL SYSTEM

To disassemble/assemble the Printer, following the instructions given in this chapter. The service person is expected to identify the cause of a fault by referring to the descriptions in Chapter 4 'Troubleshooting,' and then to replace appropriate parts according to the instructions given while heeding the following:

1. Before disassembling/assembling or moving the Printer, take out the toner cartridge if necessary. If removed, it must always be kept in a protective bag or covered with paper to protect the photosensitive drum from the effects of light (if for a short time).
2. **▲** Disconnect the power plug for disassembly/assembly work.
3. Unless otherwise noted, reverse the steps used to disassemble when assembling the Printer.
4. Identify the screws by type (length, diameter) and location.
5. As a rule, do not operate the Printer with any of its parts removed.
6. When handling a PCB, be sure to touch a metal area of the Printer to be free of static charges, thereby preventing damage to the PCB.
7. Do not touch the rubber portion of the pickup roller or the transfer charging roller with bare hands.
8. Take full care when disconnecting the flat cable. When connecting it, be sure to keep it straight, never fitting it at an angle.

I. EXTERNALS AND CONTROLS	3-1	VI. CHARGING/DEVELOPING/ CLEANING MECHANISMS	3-26
II. PCBS	3-8	VII. FIXING SYSTEM	3-27
III. DRIVE MECHANISMS	3-15	VIII. PAPER FEEDER	3-34
IV. FEEDING MECHANISMS	3-17		
V. EXPOSURE MECHANISMS.....	3-25		

I. EXTERNALS AND CONTROLS

A. External Covers

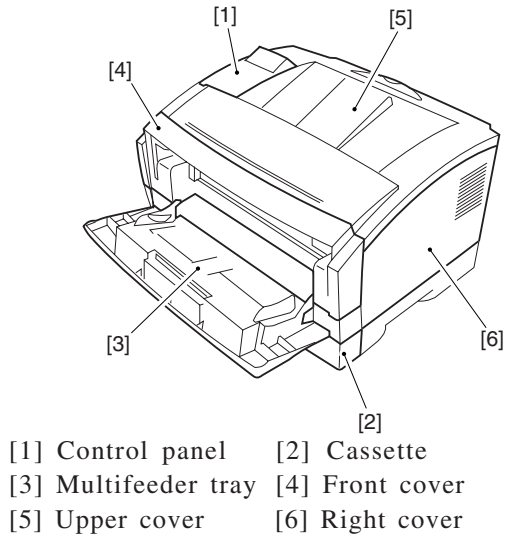

Figure 3-1-1

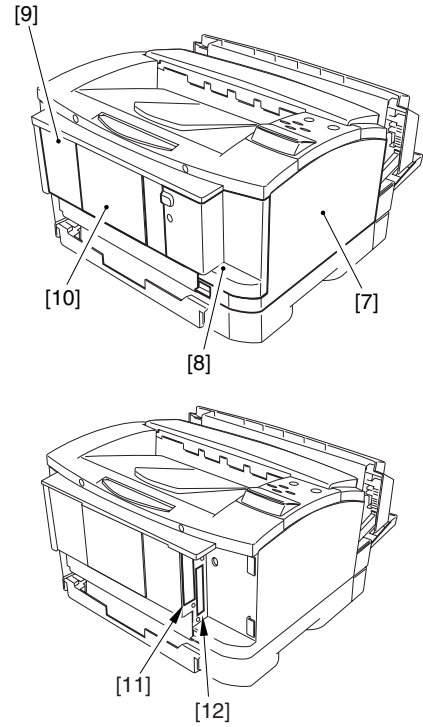

Figure 3-1-2

Remove the covers as shown when cleaning, inspecting, or repairing the inside of the Printer.

Those covers that may be detached by mere removal of mounting screws are omitted from the instructions.

1. Removing the upper cover and the control panel

- 1) Remove the expansion board slot cover.
- 2) Remove the 2 screws [1], and slide out the upper cover [2] halfway.

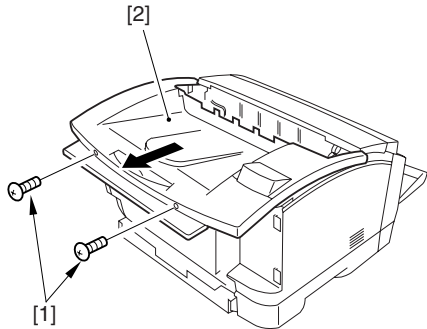

Figure 3-1-3

- 3) Remove the control panel harness [3], and detach the upper cover assembly [4].

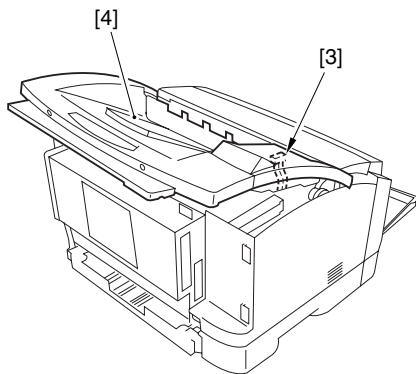

Figure 3-1-4

- 4) Remove the 2 claws [5], and detach the control panel [6].

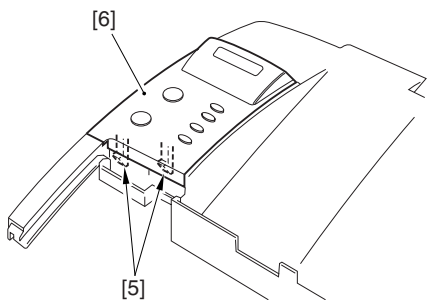

Figure 3-1-5

2. Mounting the upper cover and the control panel

- 1) Mount the upper cover [2] with 2 screws [1].

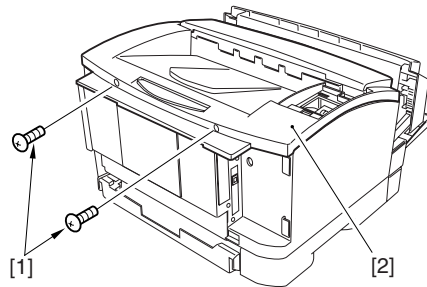

Figure 3-1-6

Caution: After mounting the upper cover, check to make sure that the control panel harness [3] is secured by the harness stop [4].

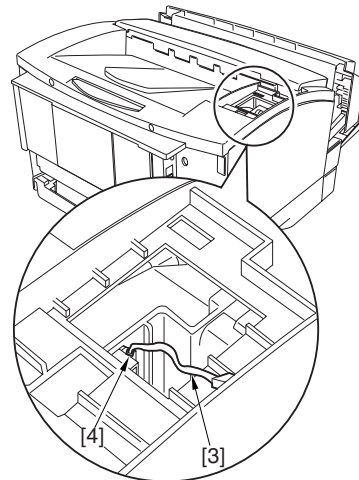

Figure 3-1-7

- 2) Connect the connector [5] to the control panel, and mount the control panel [6] to the upper cover [7].

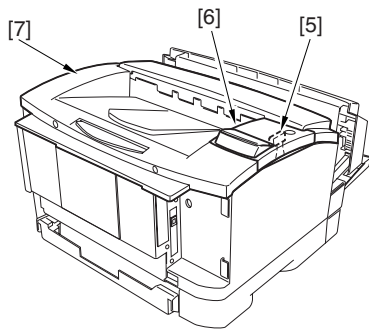

Figure 3-1-8

- 3) Mount the extension slot cover.

3. Removing the front cover

Caution: If you must work for 5 min or more, be sure to slide out the cartridge and keep it in a protective bag.

- 1) Open the multifeder tray.
- 2) Shift the open/close levers [1] found on both side of the front cover to the front, and slide out the front cover [2].

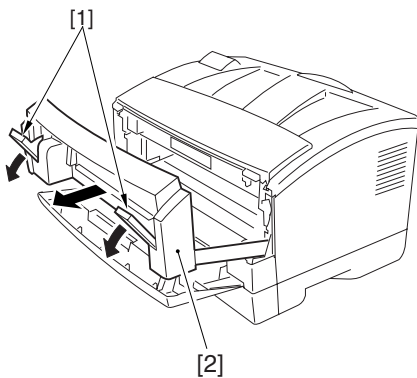

Figure 3-1-9

- 3) Lift the front cover [3] slightly to detach.

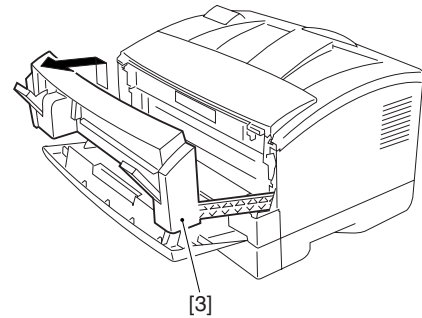

Figure 3-1-10

4. Remove the left cover

Caution: If a hard disk (option) is installed, be sure to remove it in advance. (See II-B-6 'Removing the Hard Disk (option).')

- 1) Remove the upper cover.
- 2) Slide out the front cover slightly.
- 3) Remove the screw [1], and detach the left cover [2].

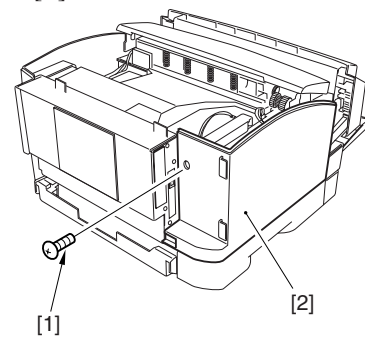

Figure 3-1-11

5. Removing the right cover

- 1) Remove the upper cover.
- 2) Slide out the front cover slightly.
- 3) Remove the screw [1], and detach the right cover [2].

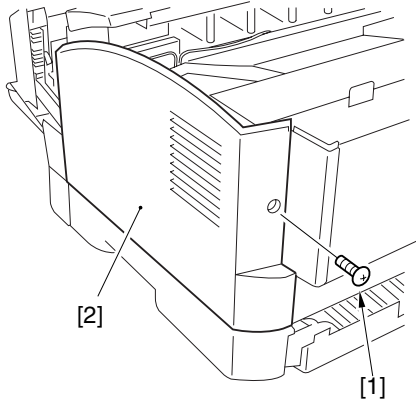

Figure 3-1-12

6. Removing the rear cover

- 1) Remove the upper cover, left cover, and right cover.
- 2) Remove the 9 screws [1], and detach the rear cover [2].

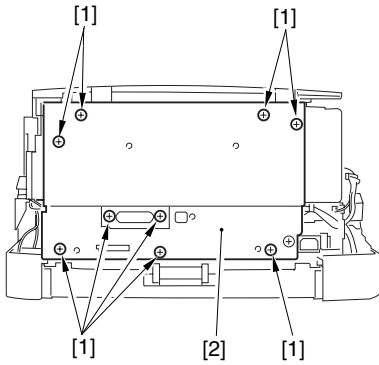

Figure 3-1-13

B. Heat Discharging Fan

1. Removing the heat discharging fan

- 1) Remove the video controller PCB. (See II-B-1 'Removing the Video Controller PCB unit.')
- 2) Disconnect the connector J109 [1] from the DC controller PCB, and free the harness from the harness guide.

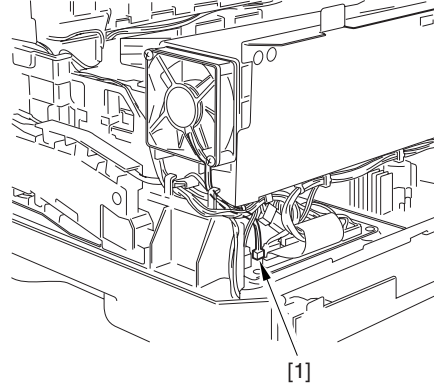

Figure 3-1-14

- 3) Remove the 2 screws [2], and detach the heat discharging fan [3].

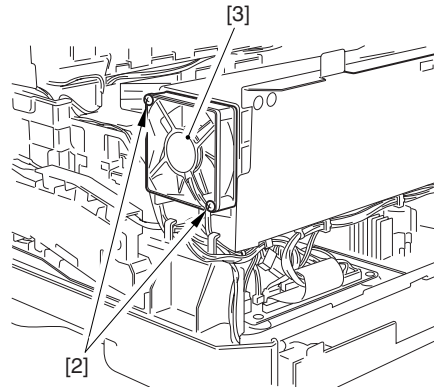

Figure 3-1-15

Caution: When mounting the heat discharging fan, be sure to pay attention to the direction of air current.

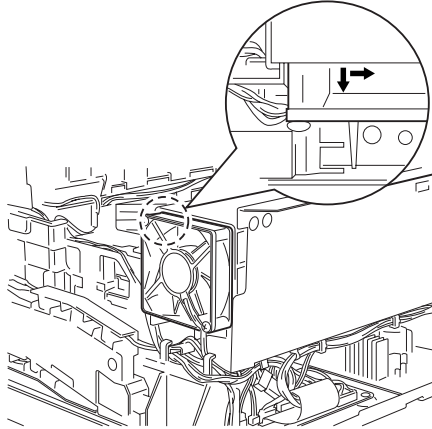

Figure 3-1-16

C. Door Switch Assembly

1. Remove the left door switch

- 1) Remove the video controller PCB. (See II-B-1 'Removing the Video Controller PCB unit.')
- 2) Disconnect the connector [1], and free the harness from the harness guide.

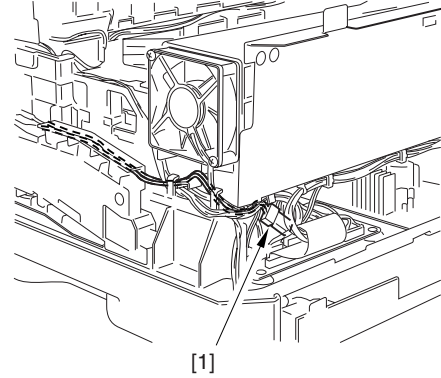

Figure 3-1-17

- 3) Remove the claw [2], and detach the left door switch [3].

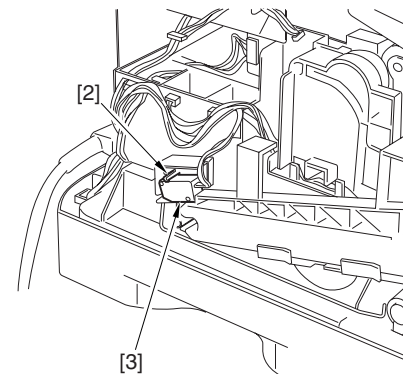

Figure 3-1-18

2. Removing the right door switch

- 1) Remove the video controller PCB. (See VII-B-1 'Removing the Video Controller PCB unit.')
- 2) Remove the drive assembly. (See III-B-1 'Removing the Drive Assembly.')
- 3) Remove the screw [1], and remove the grounding plate [2].

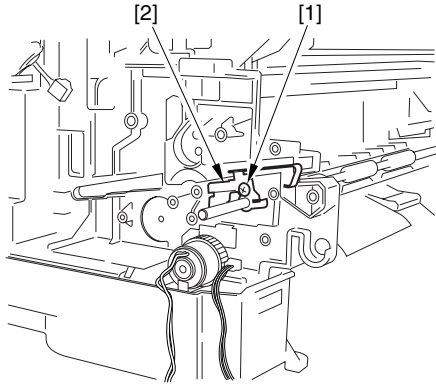

Figure 3-1-19

- 4) Disconnect the connector [3], and free the harness [4] from the harness guide.

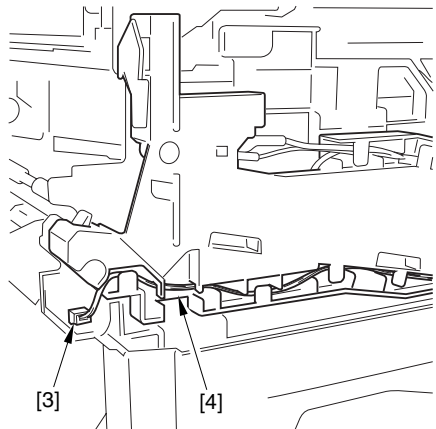

Figure 3-1-20

- 5) Remove the 3 screws [5], and open the right rail [6] slightly.

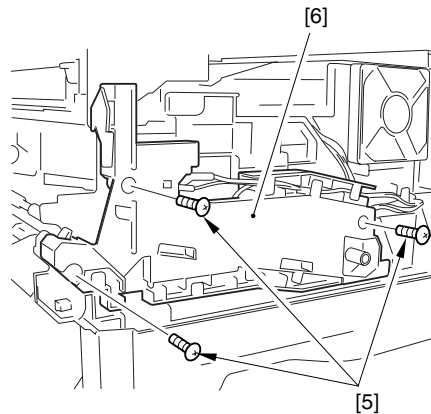

Figure 3-1-21

- 6) Remove the screw [7], and detach the grounding plate [8].
- 7) Free the grounding harness [9] from the harness guide.

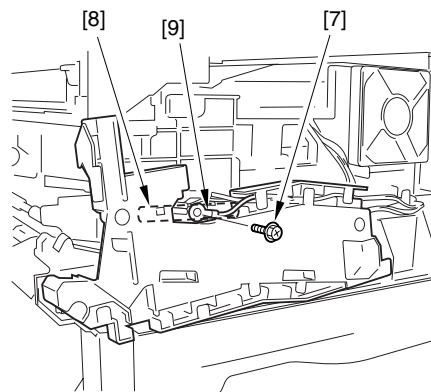

Figure 3-1-22

- 8) Disconnect the relay connector [10], and free the harness from the harness guide.

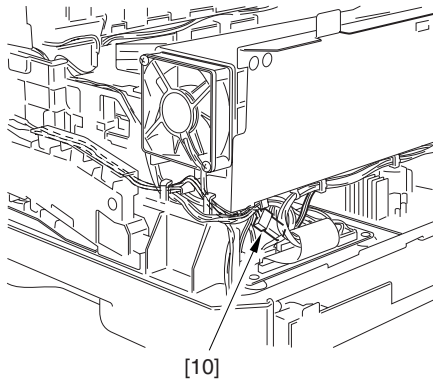

Figure 3-1-23

- 9) Remove the claw [11], and detach the right door switch [12].

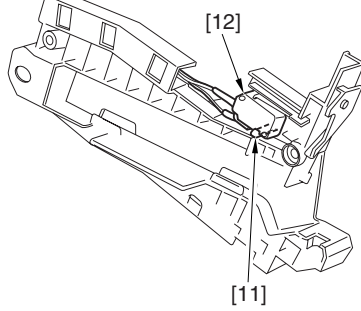
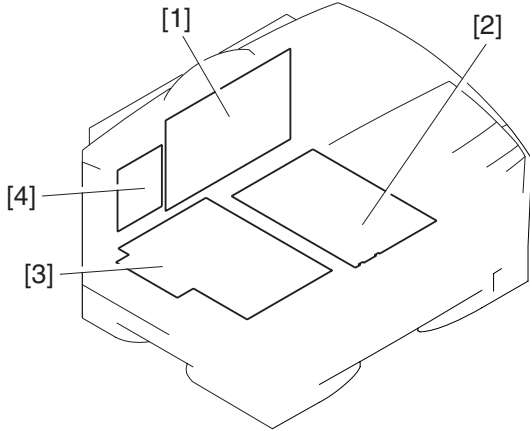

Figure 3-1-24

II. PCBS

A. Arrangement of the PCBs



- [1] Video controller PCB
- [2] DC controller PCB
- [3] Power supply PCB
- [4] Built-in print server (option)

Figure 3-2-1

B. Video Controller PCB

1. Removing the video controller PCB unit

If a standard network or option network board is connected, be sure to remove it before starting the following steps:

- 1) Remove the rear cover. (See I-A-6 'Removing the Rear Cover.')
- 2) Remove the connector cover [1].
- 3) Disconnect the connector [2] and the flexible cable [3] from the back of the PCB.

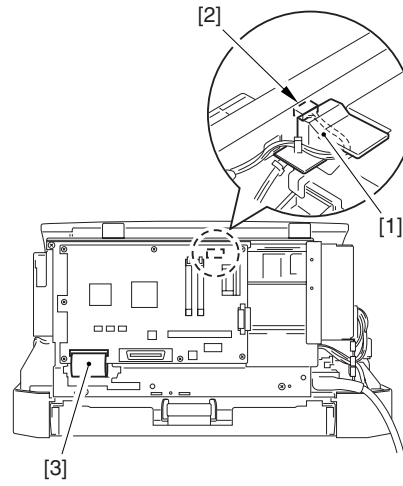

Figure 3-2-2

- 4) Remove the 4 screws [4], and detach the video controller PCB unit [5].

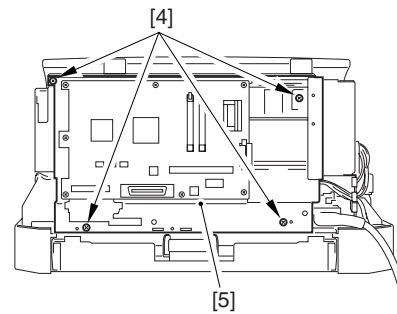

Figure 3-2-3

2. Removing the video controller PCB

- 1) Remove the rear cover. (See I-A-6 'Removing the Rear Cover.')
- 2) Remove the connector cover [1].
- 3) Disconnect the connector [2] and the flexible cable [3] from the back of the PCB.

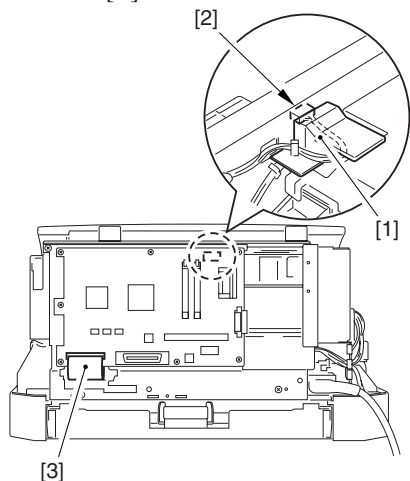

Figure 3-2-4

- 4) Remove the 7 screws [4], and detach the video controller PCB [5].

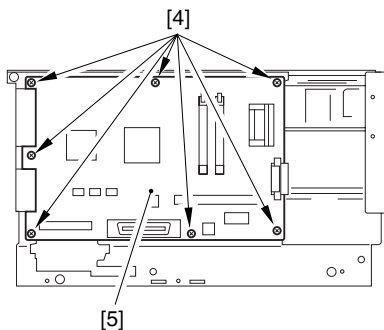

Figure 3-2-5

Caution: If the video controller PCB must be replaced, be sure to transfer the following from the old to new PCB:

1. Option RAM DIMM/ROM DIMM
2. EEP-ROM (2 pc.; IC4, IC5)

- 5) If the video controller PCB is replaced the old to the new PCB, execute the copy operation of counter at values service menu. (See VII-C Copying the Counter Readings in Chapter 4)

3. Remove the RAM DIMM/ROM DIMM (option)

The RAM/ROM is found as follows:

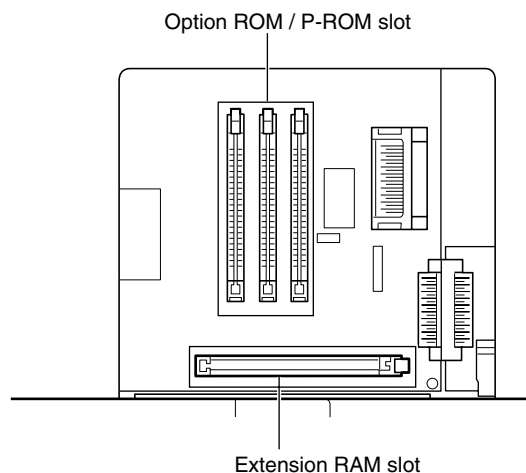

Figure 3-2-6

- 1) Taking care not to touch the elements, push down the socket lever [1]; then, remove the RAM DIMM [2] or the ROM DIMM [3].

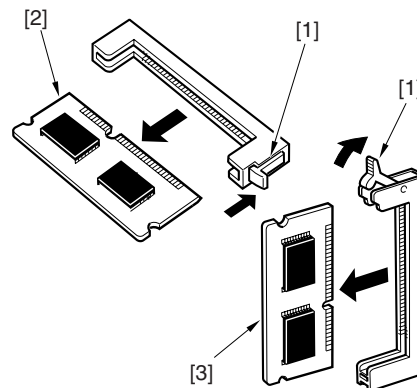
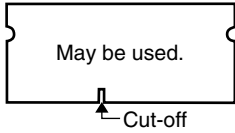

Figure 3-2-7

4. Mounting the RAM DIMM (option)

Caution: The RAM DIMM must be one specifically designed for the Printer. The location of the cut-off differs between regular RAM DIMMs and one designed for the Printer.

SDRAM DIMM (3.3 V) for Printer



RAM DIMM (3.3 V, 5 V) for others

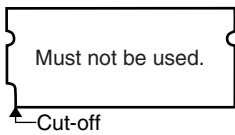

Figure 3-2-8

- 1) Holding it so that the cut-off [1] faces downward, insert the RAM DIMM [2] along the guide groove.

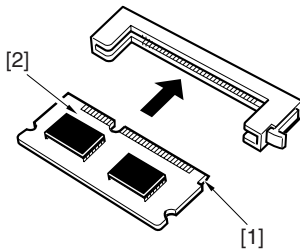

Figure 3-2-9

- 2) Check to make sure that the lever [3] is at the same position as the slot [4].

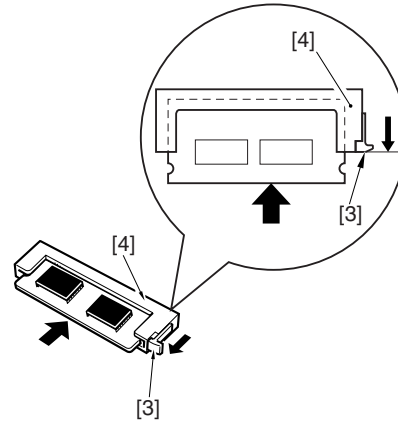
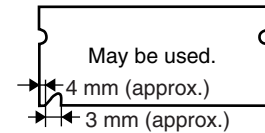

Figure 3-2-10

5. Mounting the ROM DIMM (option)

Caution: The ROM DIMM must be one specifically designed for the Printer. It differs from common ROM DIMMs as follows:

ROM DIMM (3.3 V) for Printer



ROM DIMM (3.3 V) for others

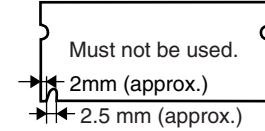

ROM DIMM (5 V) for others

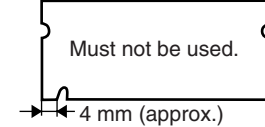

Figure 3-2-11

- 1) Push down the ROM slot lever [1].

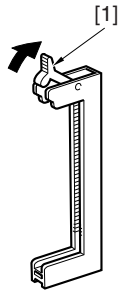

Figure 3-2-12

- 2) Holding it so that the cut-off [2] is as shown, insert the ROM DIMM [3] along the guide groove.

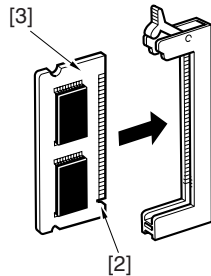

Figure 3-2-13

- 3) Check to make sure that the protrusion [4] of the lever is hooked on the groove.

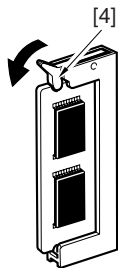

Figure 3-2-14

6. Removing the hard disk (option)

- 1) Remove the extension board slot cover and the slot cover.
- 2) Remove the 2 screws [1], and detach the hard disk [2].

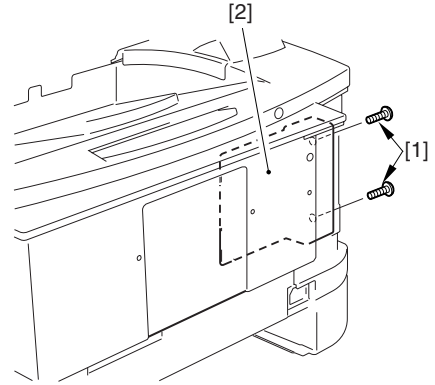

Figure 3-2-15

7. Removing the print sever (Option)

- 1) Remove the extension slot cover, slot cover, and rear cover. (See I-A-6 'Removing the Rear Cover.')
- 2) Remove the screw [1].
- 3) Remove the 2 screws [2], and detach the print sever [3].

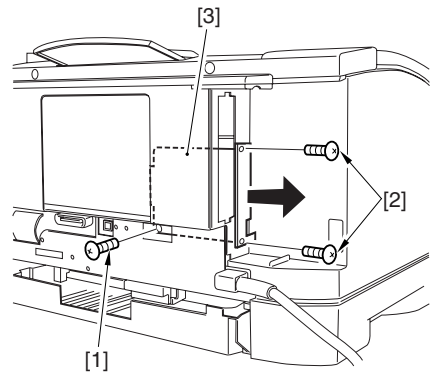

Figure 3-2-16

C. DC Controller PCB

1. Removing the DC controller PCB

The following is an outline of the work flow used to disassemble/assemble PCBs:

Note: The number within parentheses indicates the number of screws used.

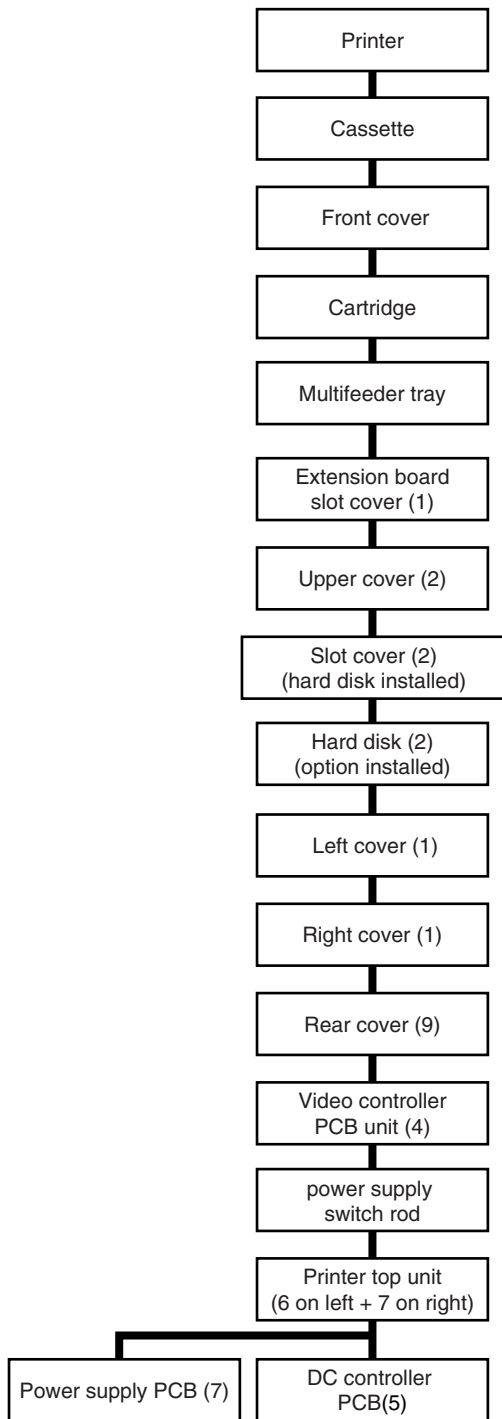

Figure 3-2-17

- 1) Remove the mulfefeeder tray. (See IV-B-1 'Removing the Mulfefeeder Tray.')
- 2) Remove the video controller PCB unit. (See II-B-1 'Removing the Video Controller PCB unit.')
- 3) Disconnect the connector [1] from the power supply PCB and the 9 connectors [2] from the DC controller PCB.

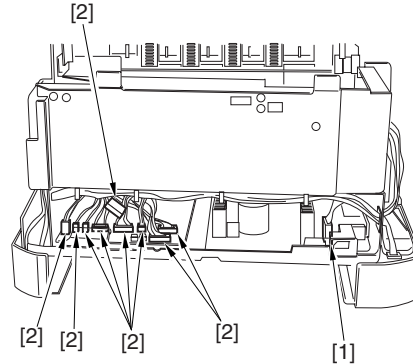

Figure 3-2-18

- 4) Free the harness [3] from the harness guide [4].

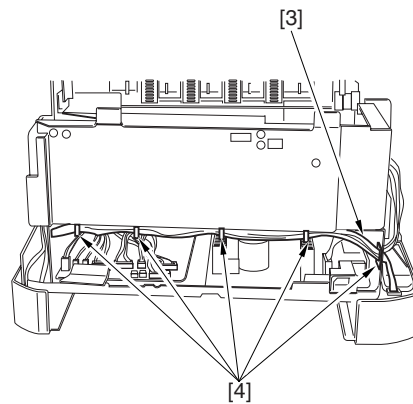

Figure 3-2-19

- 5) Remove the power switch rod [5].

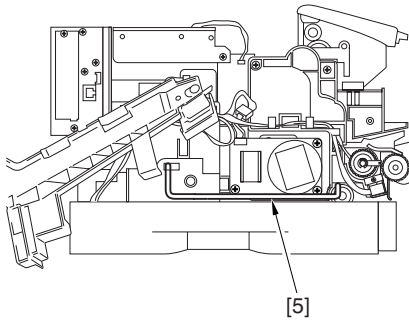

Figure 3-2-20

- 6) Remove the 6 screws [6]. Refer to the \$ marking to the side of the screw holes to identify the screws to remove. One of the screws [7] need not be removed.

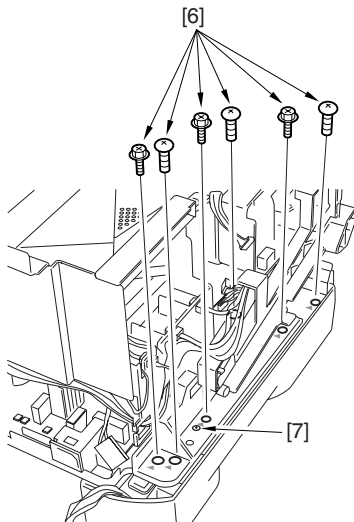

Figure 3-2-21

- 7) Remove the 7 screws [8]. Refer to the \$ marking to the side of the screw holes to identify the screws to remove. One of the screws [9] need not be removed.

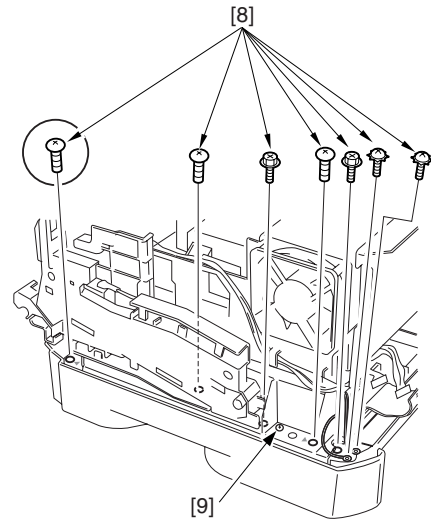

Figure 3-2-22

-
- Caution:** 1. When mounting, you will not be able to hold the screwdriver upright for screws initiated; nevertheless, be sure the screws are fitted straight.
2. Any screws with a washer must be tightened together with the respective grounding wire.
-

- 8) Holding the rails [10] on both left and right, detach the printer top unit [11].

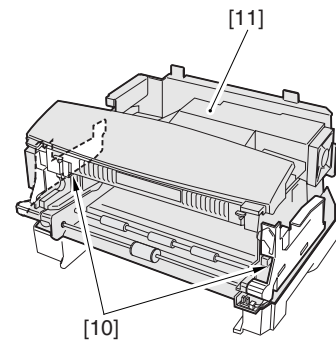

Figure 3-2-23

-
- Caution:** Be sure to place the printer top unit on a flat surface.
-

- 9) Remove the flexible cable [12], 5 screws [13], and lock support [14]; then, detach the DC controller PCB [15].

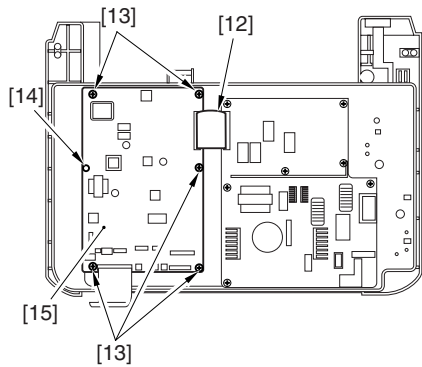

Figure 3-2-24

Caution: When mounting the printer top unit, be sure to hold it by the left and right rails; then, fit it in the frame holes while holding it horizontal and paying attention to the screw holes [16] on the base plate.

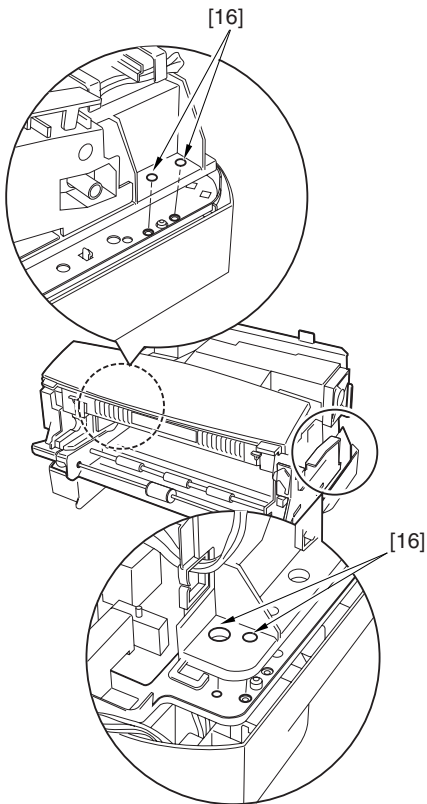

Figure 3-2-25

D. Power Supply PCB Assembly

1. Removing the power supply PCB

See II-C-1 'Removing the DC Controller PCB' for an outline of the flow of work used to disassemble/assemble the PCBs.

- 1) Remove the printer top unit. (See II-C-1 'Removing the DC Controller PCB'.)
- 2) Remove the flexible cable [1] and 7 screws [2]; then, detach the power supply PCB [3].

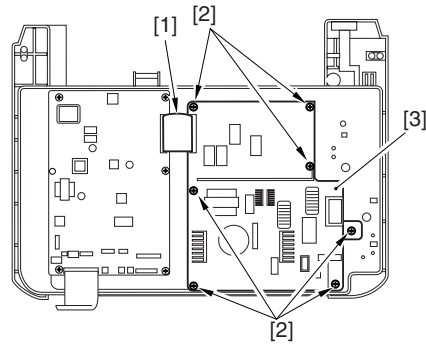

Figure 3-2-26

III. DRIVE MECHANISMS

A. Main Motor

1. Removing the main motor

- 1) Remove the front cover and the left cover. (See I-A-3 'removing the Front Cover' and I-A-4 'Removing the Left Cover.')
- 2) Remove the pickup guide assembly. (See IV-B-2 'Removing the Manual Feed Pickup Roller.')
- 3) Remove the screws [1], and open the left rail [2].

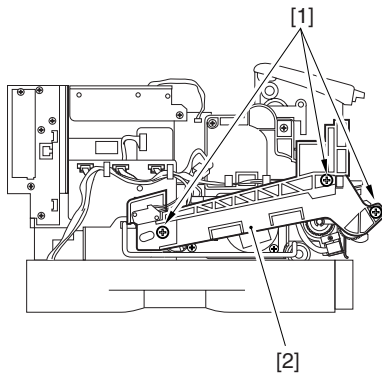

Figure 3-3-1

- 4) Remove the power supply switch rod [3].

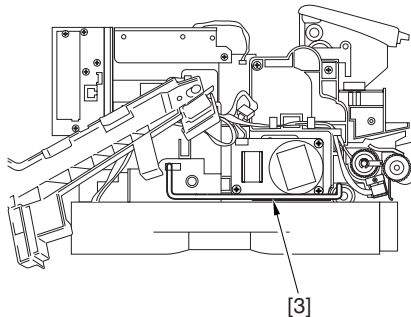

Figure 3-3-2

- 5) Disconnect the connector [4] and remove the three screws [5]; then, detach the main motor [6].

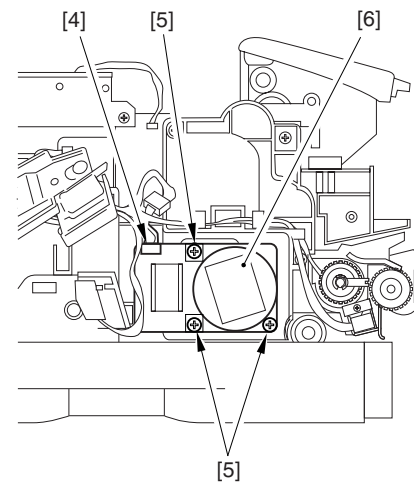

Figure 3-3-3

B. Drive Assembly

1. Removing the drive assembly

- 1) Remove the main motor. (See III-A-1 'Removing the Main Motor.')
- 2) Remove the manual feed pickup roller. (See IV-B-2 'Removing the Manual Feed Pickup Roller.')
- 3) Disconnect the 4 connectors [1], and free the harness from the harness guide [2].

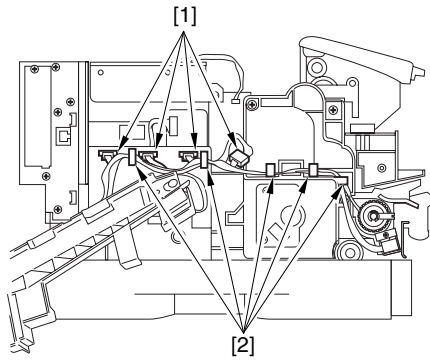

Figure 3-3-4

- 4) Remove the E-ring [3], and detach the registration clutch [4].

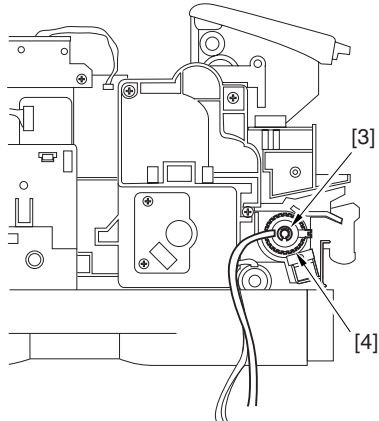

Figure 3-3-5

- 5) Remove the 4 screws [5], and detach the drive assembly [6].

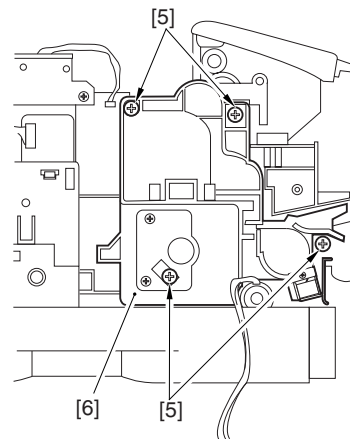

Figure 3-3-6

IV. FEEDING MECHANISMS

A. Cassette Pickup Assembly

1. Replacing the cassette pickup roller

Caution: Be sure to replace the cassette separation pad at the same time.

- 1) Slide out the cassette, and move the front of the Printer to the edge of the table.
- 2) Push the lever [1] to the left, and detach the cassette pickup roller [2].

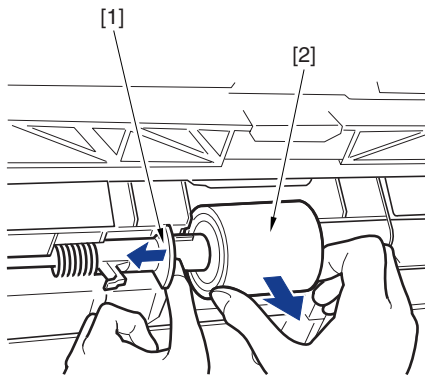

Figure 3-4-1

- 3) Holding the side with the larger hole to the left, fit the new cassette pickup roller [3].

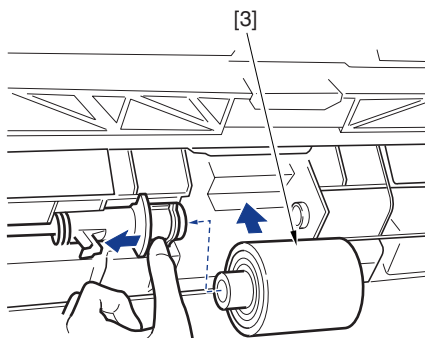

Figure 3-4-2

2. Replacing the cassette separation pad

Caution: Be sure to replace the cassette pickup roller at the same time.

- 1) Slide out the cassette, and remove all paper.
- 2) Turn over the cassette.
- 3) Pick the claw [1], and remove the cassette separation pad [2].

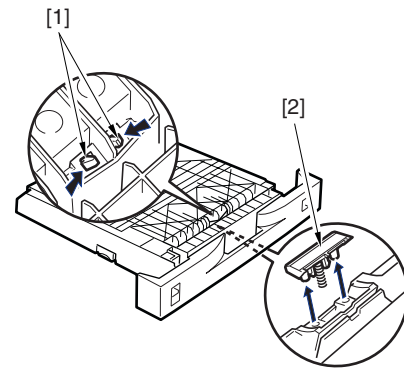

Figure 3-4-3

- 4) Mount the new spring [4] to the new cassette separation pad [3].

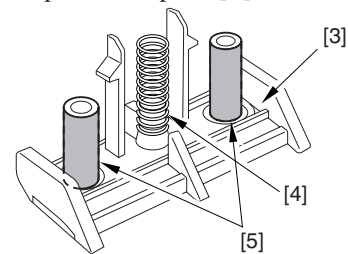

Figure 3-4-4

Caution: When replacing the cassette separation pad, be sure to apply lubricant to the sliding shaft [5] of the new separation pad, making sure that the coating is thin and even. See that that lubricant is kept away from areas other than the above.

- 5) Mount the new cassette separation pad [3] and the spring [4] at the same time.

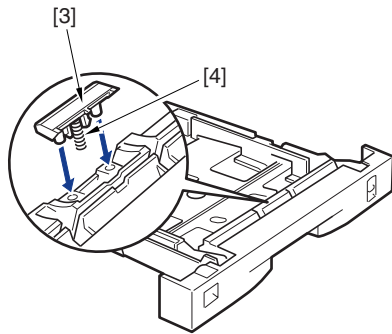

Figure 3-4-5

3. Removing the paper size selecting switch

- 1) Remove the printer top unit. (See II-C-1 'Removing the DC Controller PCB.')
- 2) Remove the 2 claws [1], and detach the left cassette rail assembly [2] from the bottom frame.

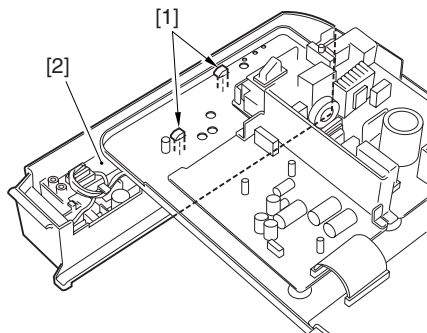

Figure 3-4-6

- 3) Disconnect the 3 connectors [3], and free the harness form the harness guide.
- 4) Remove the 2 screws [4].

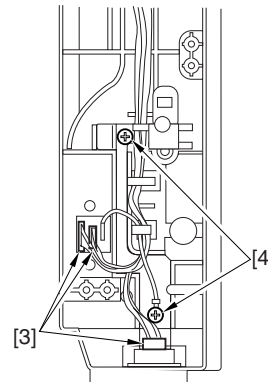

Figure 3-4-7

- 5) Remove the 2 claws [5], and detach the paper size detecting switch [7] together with the grounding plate [6].

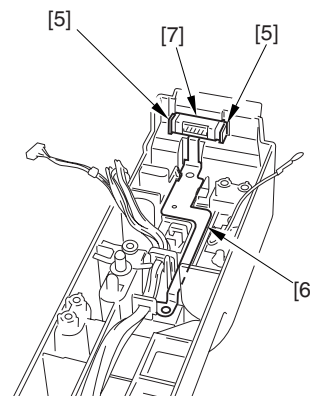

Figure 3-4-8

- 6) Remove the 2 upper claws (longer) [8] and the 2 lower claws (shorter) [9]; then, detach the grounding plate [10]. Detach the paper size detecting switch [11].

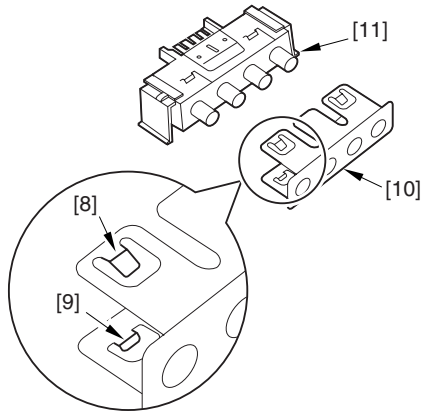

Figure 3-4-9

- 4) Remove the cassette pickup clutch [3].

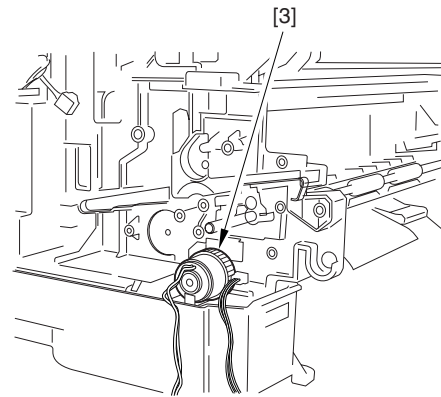

Figure 3-4-11

4. Removing the cassette pickup clutch

- 1) Remove the drive assembly. (See III-B-1 'Removing the Drive Assembly.')
- 2) Remove the cassette pickup roller. (See IV-A-1 'Replacing the Cassette Pickup Roller.')
- 3) Holding the lock knob [1], slide the roller shaft [2] to the right until it stops.

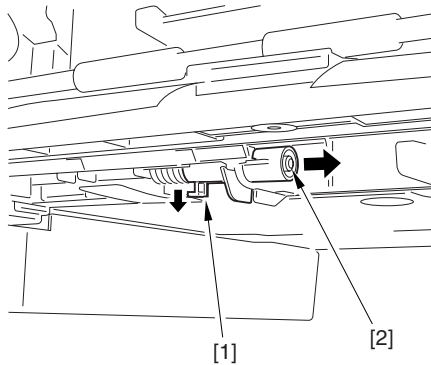

Figure 3-4-10

B. Multifeder Tray Pickup Assembly

1. Removing the multifeder tray

- 1) Slide out the cassette, and detach the front cover. (See I-A-3 'Removing the Front Cover.')
- 2) Lift the claw on each side [1] to detach, one after the other.

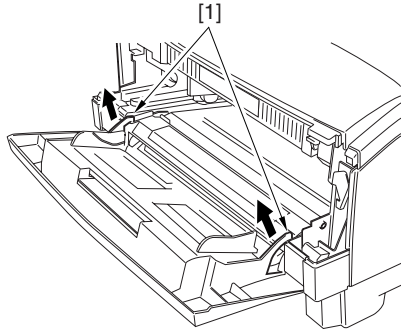

Figure 3-4-12

- 3) Pull the multifeder tray [2] to the front and down to detach.

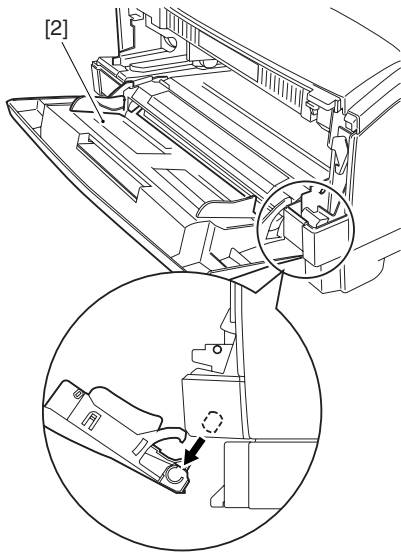

Figure 3-4-13

Caution: After mounting, check to make sure that the holding plate [4] is pushed down by the manual feed pickup roller cam [3].

If the holding plate is up, turn the manual feed pickup roller [5] using lint-free paper (so as to avoid contact with the roller surface) while pushing down the holding plate until the holding plate is lower than the manual feed pickup roller cam.

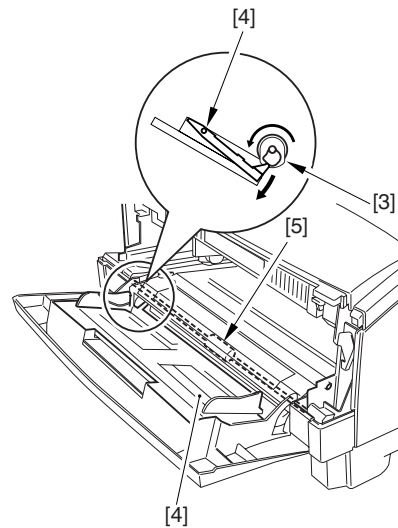

Figure 3-4-14

2. Removing the manual feed pickup roller

- 1) Remove the multifeder tray. (See IV-B-1 'Removing the Multifeder Tray.')
- 2) Remove the 2 stepped screws [1]; holding it as shown, lift the pickup guide plate [2] to detach to the front.

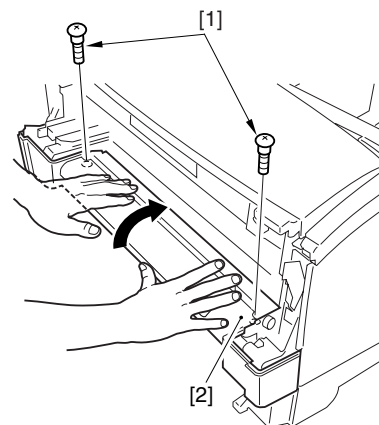

Figure 3-4-15

Caution: When mounting the pickup guide assembly, be sure to refer to the following diagram. Take care not to damage or leave out the sensor [3].

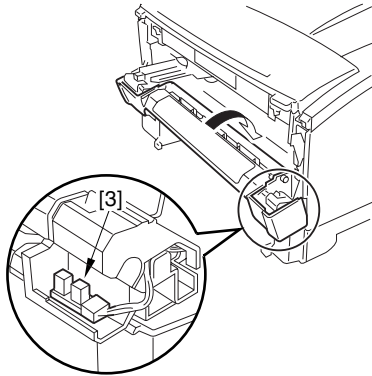

Figure 3-4-16

3. Mounting the Manual Feed Pickup Roller

- 1) Fit the left side of the manual feed pickup roller [1] into the machine; then, fit the right side of the shaft to mount the gear [2], and fit the left side of the shaft.

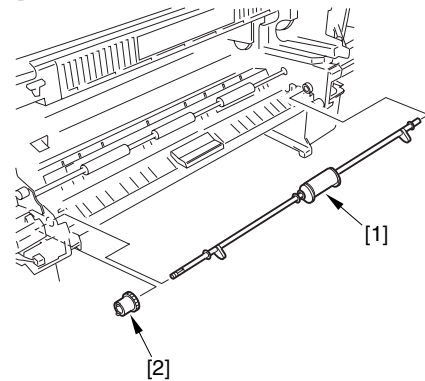

Figure 3-4-18

- 3) Remove the screw [4] with a flat-blade screwdriver, and detach the manual feed pickup roller [5] and the gear [6].

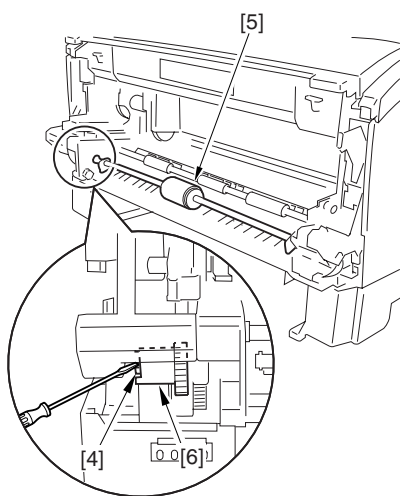

Figure 3-4-17

- 2) Rotate the manual feed pickup roller [1] until it stops, making sure that the cam [2] is as indicated.

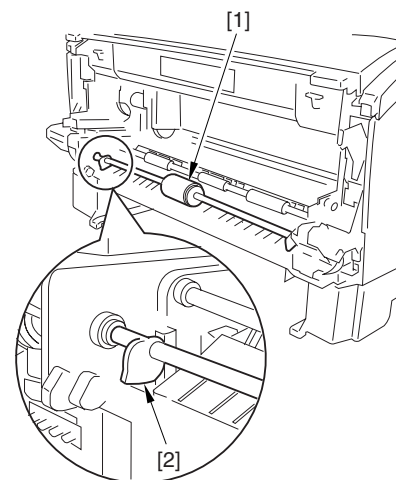

Figure 3-4-19

- 3) Thereafter, reverse the steps used to remove it.

4. Removing the manual feed separation pad

- 1) Remove the manual feed pickup roller. (See IV-B-1 'Removing the Multifeder Tray.')
- 2) Remove the manual feed separation pad [1].

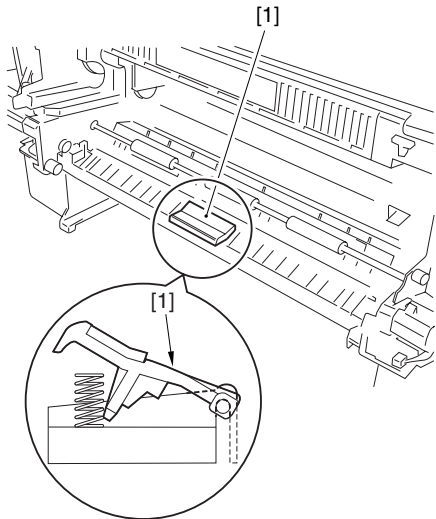

Figure 3-4-20

5. Removing the multifeder paper sensor

- 1) Remove the right cover. (See I-A-5 'Removing the Right Cover.')
- 3) Disconnect the connector [1].
- 4) Remove the claws [2], and detach the multifeder paper sensor [3].

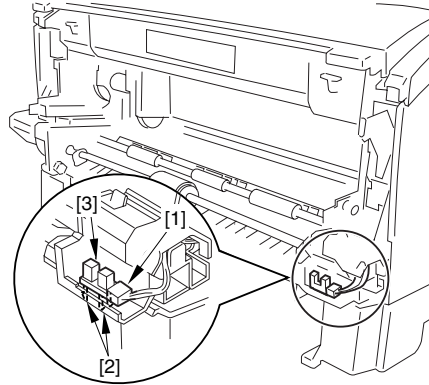

Figure 3-4-21

6. Remove the multifeder pickup solenoid

- 1) Remove the left rail and the power supply switch rod. (see III-A-1 'Removing the Main Motor.')
- 2) Disconnect the connector [1].

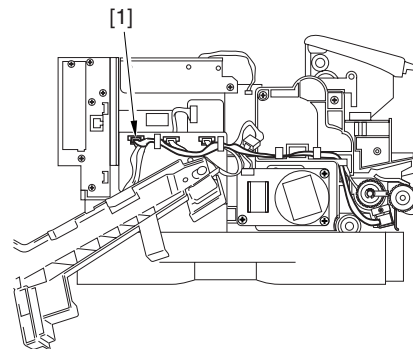

Figure 3-4-22

- 3) Remove the screw [2], and detach the multifeeder pickup solenoid [3].

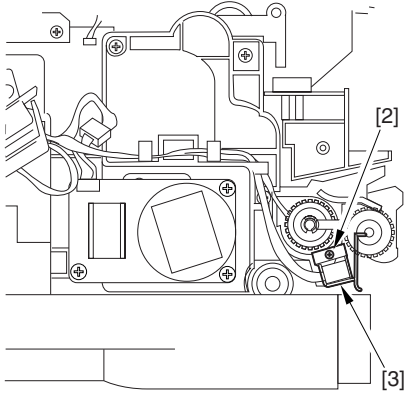

Figure 3-4-23

C. Registration Roller Assembly

1. Removing the registration roller

- 1) Remove the drive assembly. (See III-B-1 'Removing the Drive Assembly.')
- 2) Remove the screw [1], and detach the grounding plate [2].

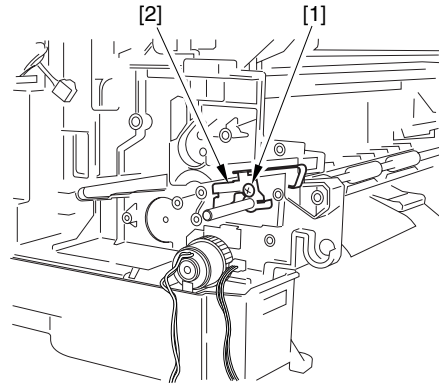

Figure 3-4-24

- 3) Pull off the bushing [3] on the left to the left.
- 4) Remove the caw [4] on the right, and detach the registration roller assembly [5].

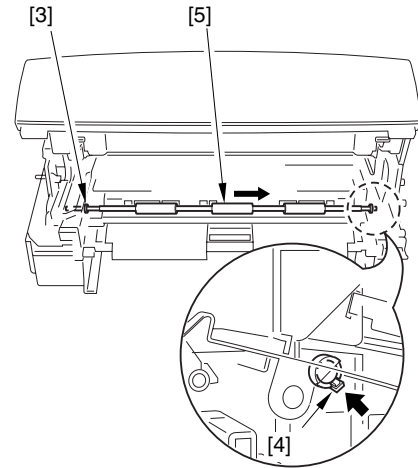

Figure 3-4-25

- 5) Remove the stepped screw [6], and detach the bushing [7].
- 6) Remove the registration roller [8].

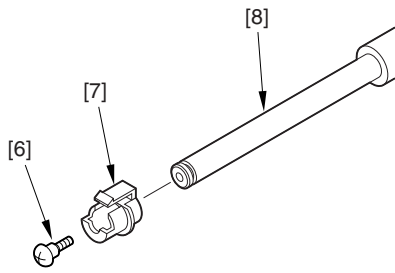

Figure 3-4-26

2. Removing the registration paper sensor

- 1) Remove the printer top unit. (See II-D-1 'Removing the DC Controller PCB'.)
- 2) Remove the drive assembly. (See III-B-1 'Removing the Drive Assembly'.)
- 3) Remove the 2 claws [1], and detach the registration paper sensor [2].

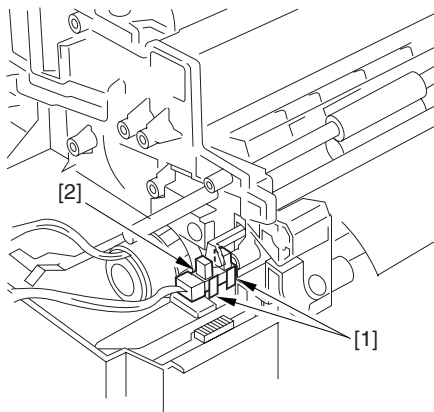

Figure 3-4-27

V. EXPOSURE MECHANISMS

A. Laser/Scanner Assembly

1. Construction

The following show the construction of the laser/scanner assembly.

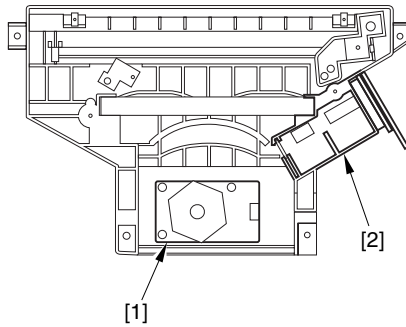

[1] Scanner assembly [2] Laser assembly

Figure 3-5-1

2. Removing the laser/scanner assembly

- 1) Remove the cartridge.
- 2) Remove the connector cover [1] and connector [2].
- 3) Remove the 5 claws [3], and detach the scanner upper cover [4].

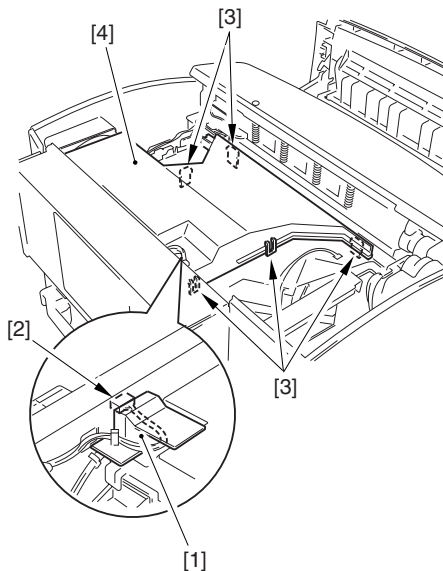

Figure 3-5-2

- 4) Remove the dust-proofing sponge [5].

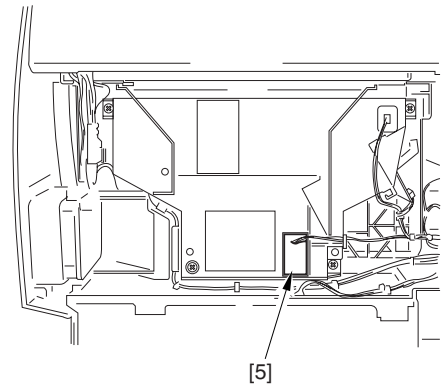

Figure 3-5-3

- 5) Disconnect the 3 connectors [6].

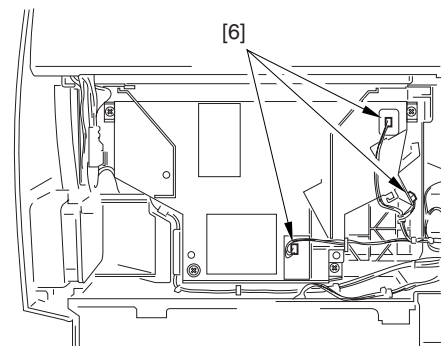

Figure 3-5-4

- 6) Remove the 4 screws [7], and detach the laser/scanner assembly [8].

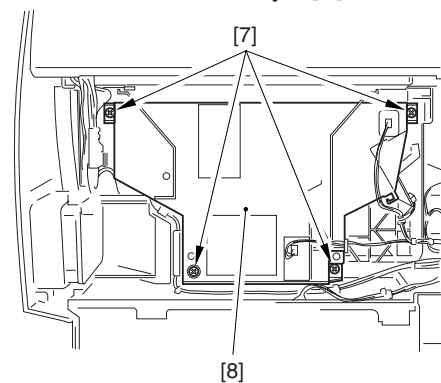

Figure 3-5-5

Caution: The laser/scanner assembly cannot be adjusted in the field. Do not disassemble it.

VI. CHARGING/DEVELOPING/ CLEANING MECHANISMS

A. EP-65 Cartridge

1. Construction

The EP-65 cartridge consists of a photosensitive drum, primary charging roller, developing assembly, and cleaner, but its construction does not permit disassembly.

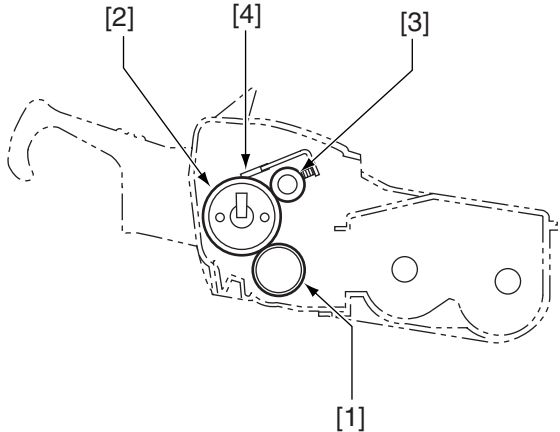

- [1] Developing cylinder
- [2] Photosensitive drum
- [3] Primary charging roller
- [4] Blade

Figure 3-6-1

Caution: If the photosensitive drum is exposed to strong light, the resulting photo memory can cause white spots or black belts on copies.

2. Photosensitive drum

Do not touch or clean it.

B. Transfer Charging Roller

1. Removing the transfer charging roller

- 1) Remove the front cover. (See I-A-3 'Removing the Front Cover.')
- 2) Holding the shaft assembly [1], detach the transfer charging roller [2].

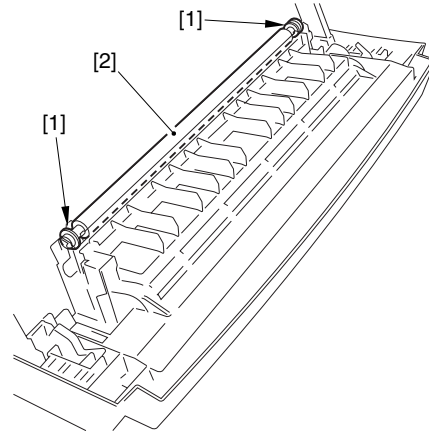

Figure 3-6-2

-
- Caution:**
1. Do not hold the roller area of the transfer charging roller. When cleaning it, do not touch the roller and take care so that it is free of solvent and oil.
 2. To clean the transfer charging roller, dry wipe it using lint-free paper (without paper lint).
 3. The transfer charging roller may be replaced if white spots or dirt on the backs of copies cannot be corrected by wiping off paper lint or toner with lint-free paper, or if the roller is deformed.
-

VII. FIXING SYSTEM

A. Fixing Assembly

1. Construction

The fixing assembly has the following construction:

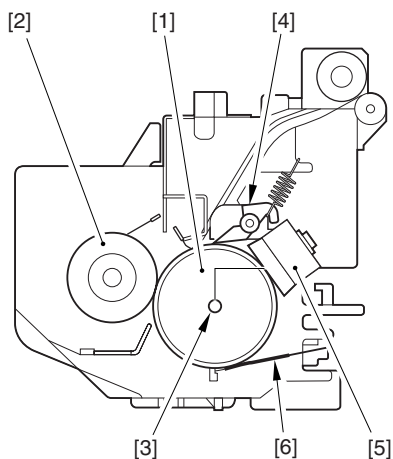

Figure 3-7-1

- [1] Fixing roller
- [2] Pressure roller
- [3] Fixing heater
- [4] Separation claw
- [5] Thermal switch
- [6] Thermistor

Note: If you have to remove any part of the fixing system, be sure to turn off the power, disconcert the power plug, and let it cool before doing so.

2. Cleaning the inside of the fixing assembly or replacing its parts

Note: Do not disassemble or clean the following parts found inside the fixing assembly in the field; a small inaccuracy in the torque or adjustment, or deformation by cleaning work, can cause smoking and flaming:

- Thermistor
 - Thermal switch
-

3. Removing the fixing assembly

- 1) Remove the upper cover. (See I-A-1 of this chapter.)
- 2) Open the fixing upper cover.
- 3) Remove the claw [1], and remove the gear [2].

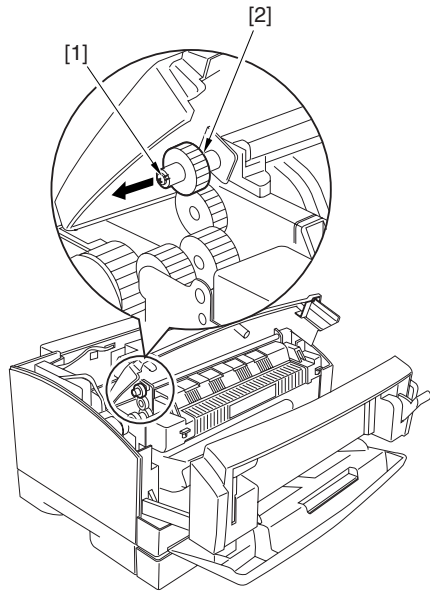

Figure 3-7-2

- 4) Pull the fixing upper cover [3] to the front; then, slide it to the right to detach.

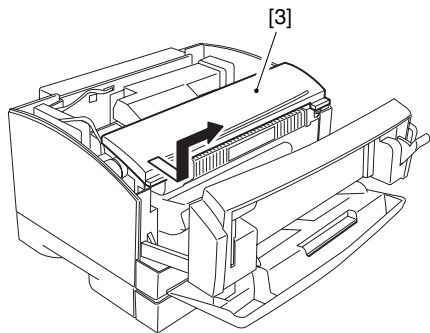

Figure 3-7-3

- 5) Disconnect the 2 connectors [4], and free the harness from the harness guide.

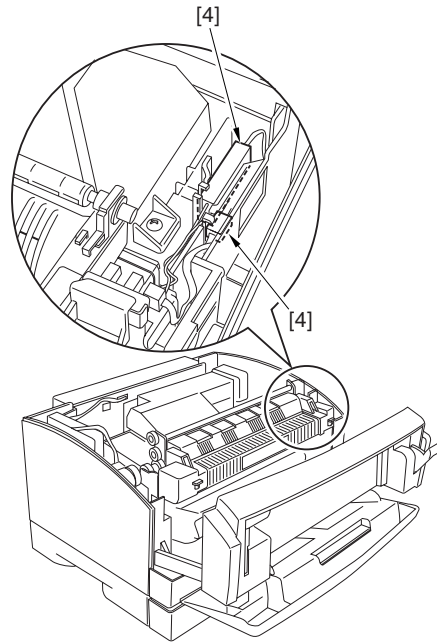

Figure 3-7-4

- 6) Disconnect the connector [5].

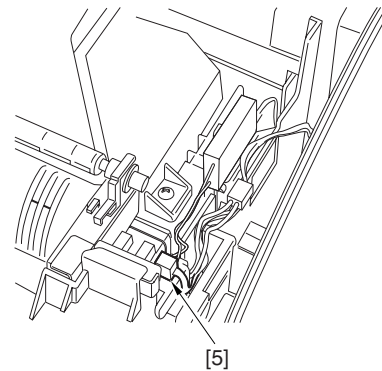

Figure 3-7-5

- 7) Remove the 2 screws [6], and detach the fixing assembly [7].

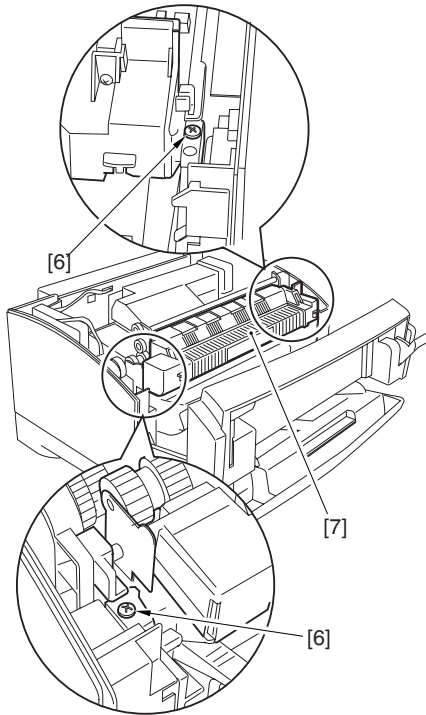

Figure 3-7-6

4. Removing the pressure roller

- 1) Remove the fixing assembly. (See VII-A-3 of this chapter.)
- 2) Push down the pressure releasing lever [1] to remove the pressure.

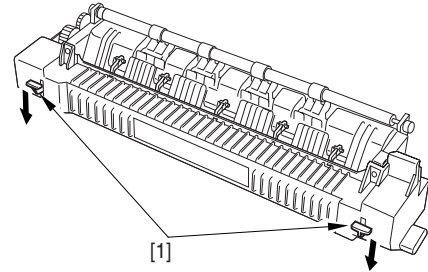

Figure 3-7-7

- 3) Remove the 2 screws [2], and detach the 2 linking plates [3]. Be sure not to remove the spring [4].

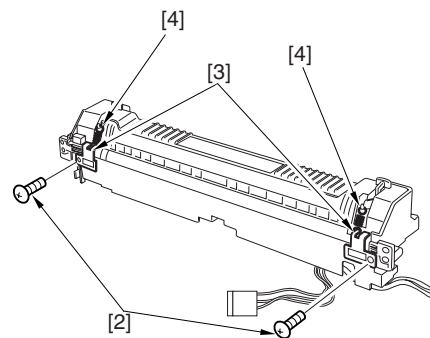

Figure 3-7-8

Note: When removing the linking plate [2], take care, as the spring [4] tends to come off easily.

- 4) Remove the 2 screws [5], open the pressure roller assembly [6] to about 90, remove the D-cut shaft on the right, and slide it to the right to remove. When opening the pressure roller assembly, apply force as necessary.

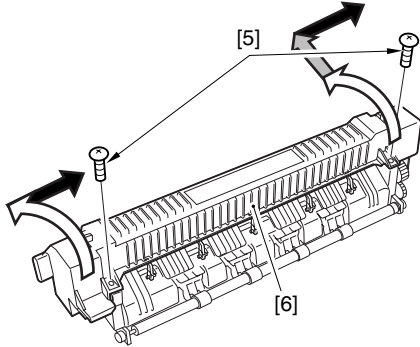

Figure 3-7-9

- Note:**
1. The static eliminating brush [7] can become displaced. Take care not to lose it.
 2. Be sure to place the fixing roller assembly [8] on a flat surface so that it will not tilt; otherwise, the fixing roller can come off the bushing.

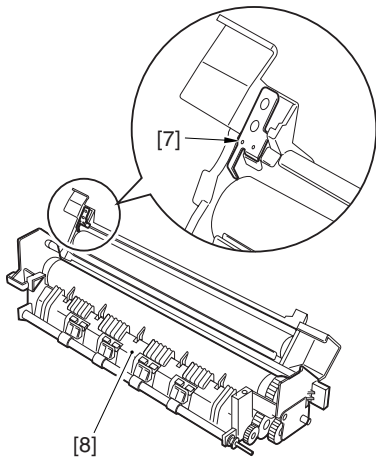

Figure 3-7-10

- 5) Remove the 2 screws [9] of the pressure roller assembly, and remove the inlet guide [10].

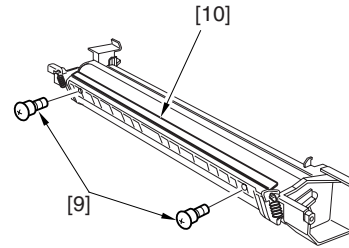

Figure 3-7-11

- 6) Remove the spring [11], and detach the bushing [12], pressure releasing lever [13], and support plate [14].
- 7) Remove the pressure roller [15].

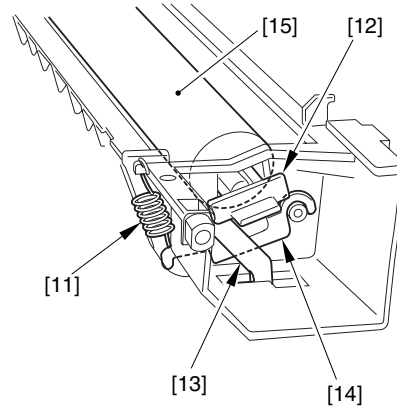

Figure 3-7-12

- Note:** When mounting the pressure roller, check to be sure that the contact plate [16] is in contact with the inlet guide [17].

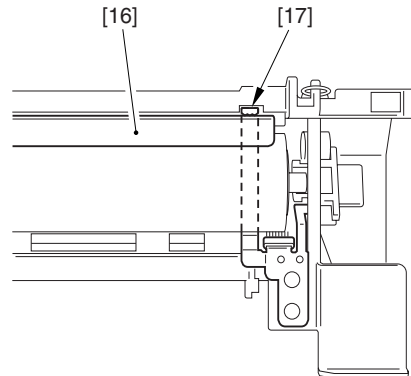

Figure 3-7-13

5. Removing the fixing roller and the fixing heater

- 1) Remove the pressure roller assembly. (See VII-A-4 of this chapter.)
- 2) Remove the 2 screws [1] of the fixing roller assembly; then, detach the fixing roller [2] and the fixing heater [3].

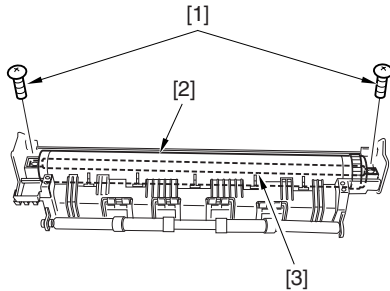

Figure 3-7-14

- 3) Check the thermistor [4] and the thermal switch [5] for scratches, dirt, and deformation. If any, replace the fixing assembly.

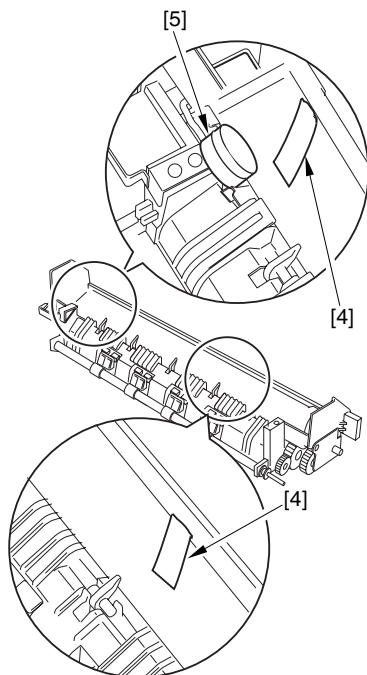

Figure 3-7-15

Note: Do not clean the thermistor [4] or the thermal switch [5].

6. Mounting the fixing roller and the fixing heater

- 1) Open the separation claws [1]. Obtain a sheet of A3/11 x 17 white paper, fold it in 4, and fit it as shown.
- 2) Holding the fixing roller [2] and the fixing heater [3], place them on the fixing assembly while the separate claws [1] are open.

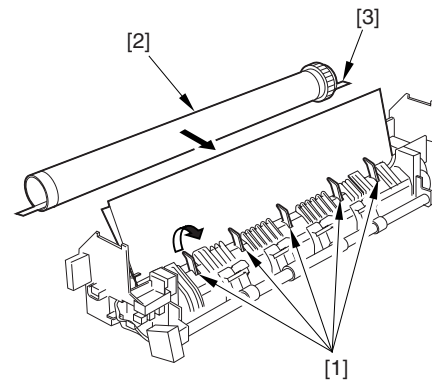

Figure 3-7-16

- 3) Remove the paper.

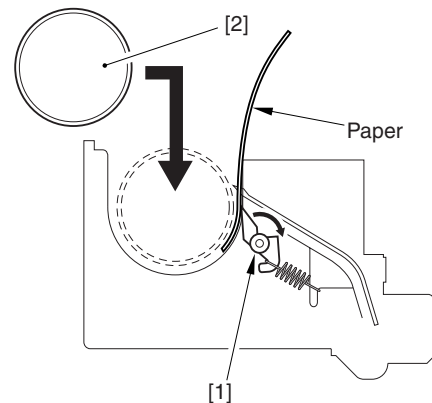

Figure 3-7-17

- Note:**
1. Be sure to mount the fixing heater so that its edge with print faces upward.
Further, take care not to touch the glass portion of the fixing heater.
 2. When mounting the fixing roller [2], take care not to scratch it by any of the separation claws. Further, be sure that the fixing roller is slid to the gear side [4].

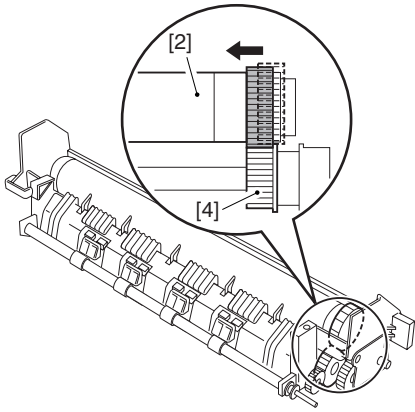

Figure 3-7-18

- 4) Prepare a length of paper (plain paper) cut to a width of about 20 mm.
- 5) Put the length of paper between the thermistor [6] and the fixing roller [7]; then, check to make sure that the thermistor [6] is in firm contact with the fixing roller [7].

• **Front View**

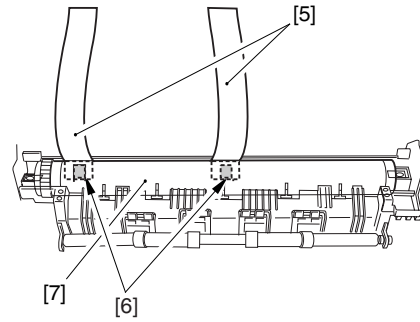

Figure 3-7-19

• **Cross Section**

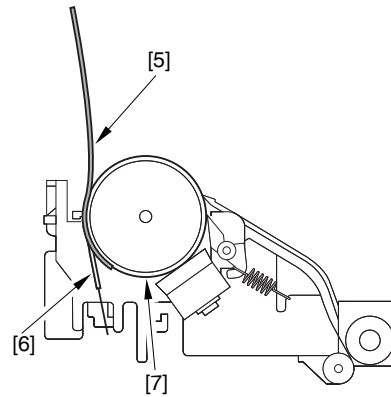

Figure 3-7-20

- 6) After mounting the fixing roller and the fixing heater, push the fixing aluminum core [8] with your finger lightly so as to make sure that the thermal switch [9] returns to its initial position by the spring.

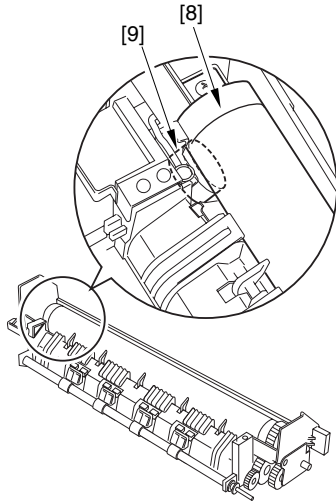

Figure 3-7-21

- 8) After making the check, mount the fixing assembly to the machine using the steps used to remove it but in reverse.

- 7) Check to make sure that the static removing brush [10] is in contact with the fixing roller core [11].

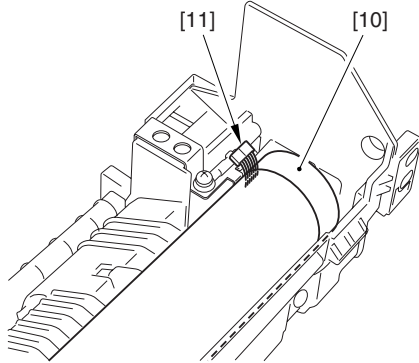
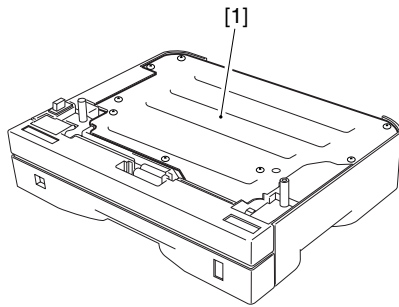

Figure 3-7-22

VIII. PAPER FEEDER

A. External Covers



[1] Top plate (7)

Figure 3-8-1

B. Pickup Assembly

1. Replacing the cassette pickup roller

See IV-A-1 'Replacing the Cassette Pickup Roller.'

2. Replacing the cassette separation pad

See IV-A-2 'Replacing the Cassette Separation Pad.'

3. Cassette paper sensor

- 1) Remove the top plate.
- 2) Disconnect the connector [1], and detach the cassette paper sensor [2].

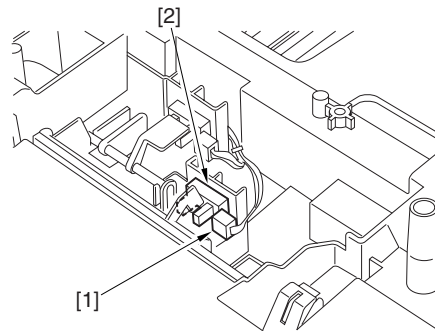

Figure 3-8-2

4. Removing the paper feeder paper sensor

- 1) Remove the top plate.
- 2) Disconnect the connector [1], and detach the paper feeder paper sensor [2].

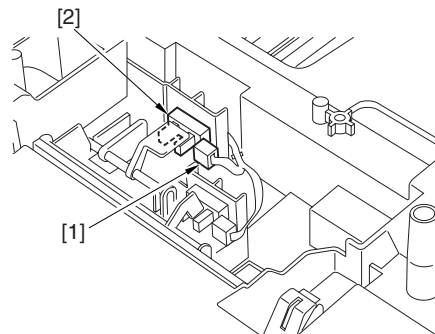

Figure 3-8-3

5. Removing the paper size detecting switch

- 1) Remove the paper feeder pickup assembly. (See steps 1) and 2) of VIII-C-1 'Removing the Paper Feeder Pickup Clutch.')
- 2) Remove the screw [1], and disconnect the connector [2]; then, detach the paper switch assembly [3].

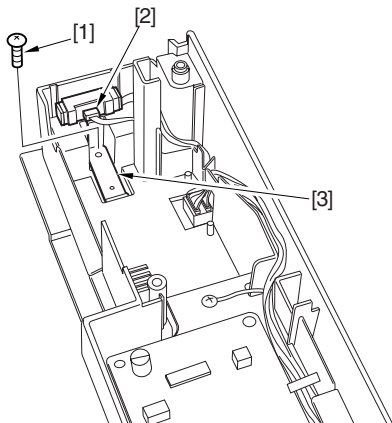

Figure 3-8-4

- 3) Remove the grounding plate [4].

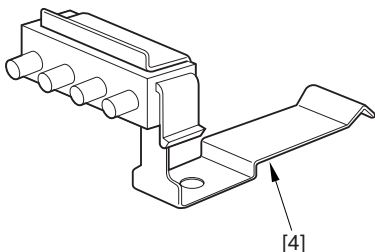

Figure 3-8-5

- 4) Remove the 2 paper claws (longer) [5] and the 2 lower claws (shorter) [6]; then, detach the grounding plate [7]. Remove the paper size detecting switch [8].

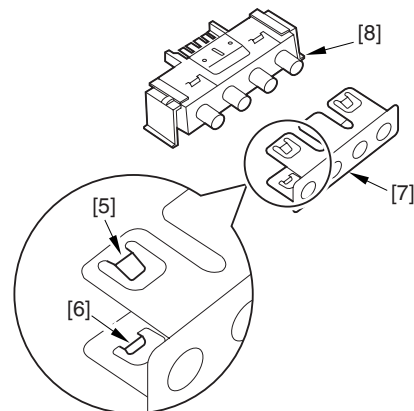

Figure 3-8-6

6. Removing the feed roller

Caution: The roller slave assembly is adjusted for height; be sure to take care not to impose an extra load on the slave roller bushing [1] when performing steps 3) through 7).

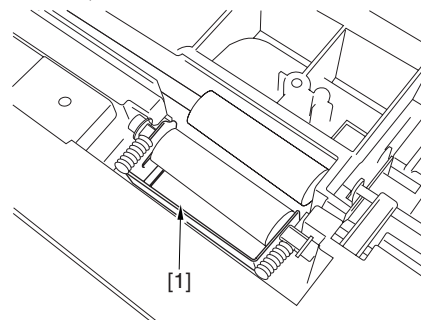

Figure 3-8-7

- 1) Remove the paper feeder pickup assembly. (See VIII-C-1 'Removing the Paper Feeder Pickup Clutch.')
- 2) Remove the screw [1], and detach the grounding plate [2].

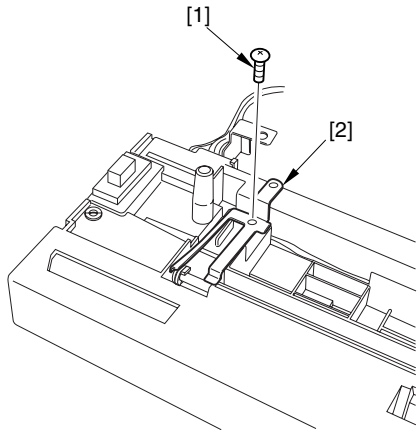

Figure 3-8-8

Caution: When mounting, be sure that the ground plate [2] is as indicated.

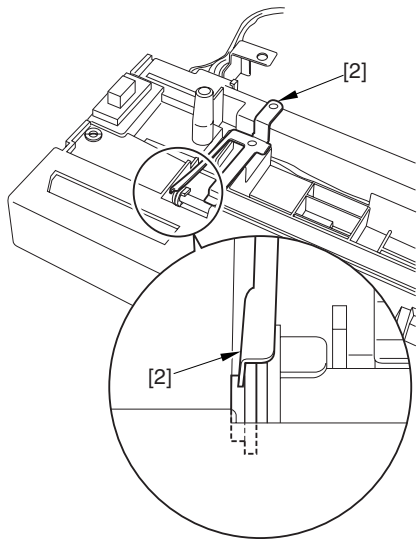

Figure 3-8-9

- 3) Remove the 2 springs [3].

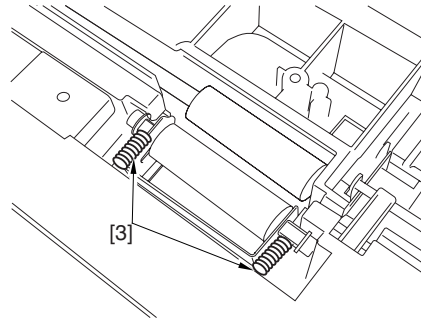

Figure 3-8-10

Caution: When mounting, hold down the pickup roller slave assembly [4] so that the spring [3] is as shown; then, fit the spring [3] with the boss [5].

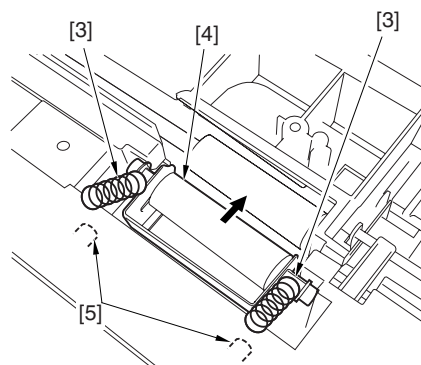

Figure 3-8-11

- 4) Slide the slave roller assembly [4] slightly to the front.

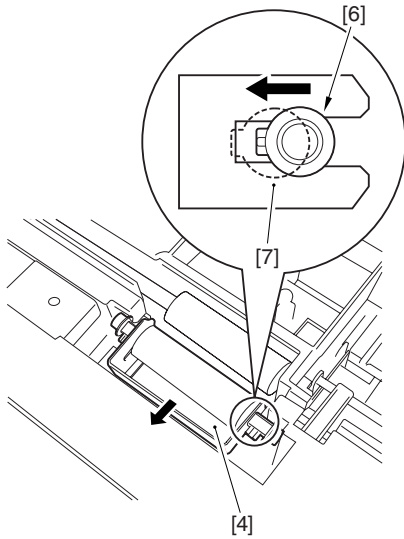

Figure 3-8-12

Caution: Take care so that the bushing [6] will not slip off the bushing [7].

- 5) Remove the 2 E-rings [8], and detach the gear [9].

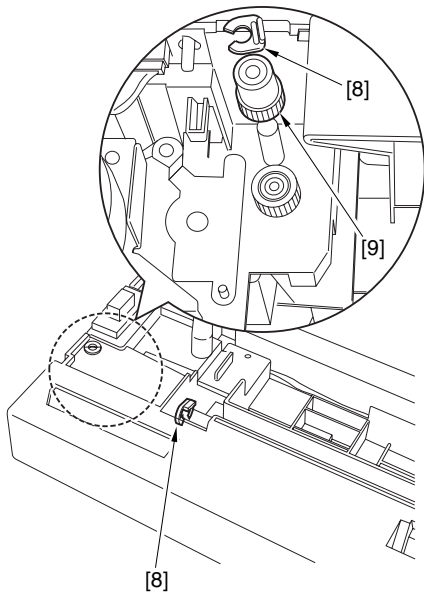

Figure 3-8-13

- 6) Slide the feeding roller assembly [10] to the right to detach.

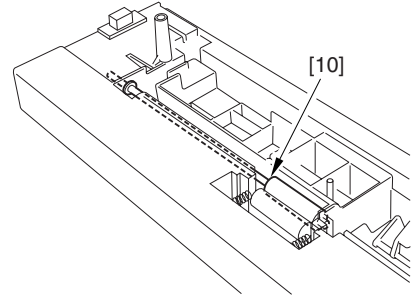

Figure 3-8-14

- 7) Remove the bushing [11] and the bushing [12].

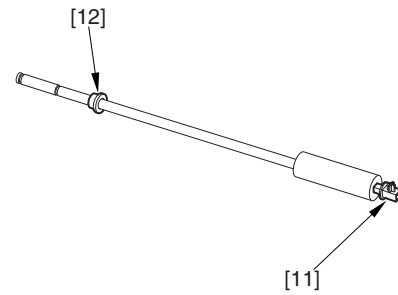

Figure 3-8-15

C. Drive Mechanism

1. Removing the paper feeder pickup clutch

- 1) Disconnect the 4 connectors [1], and free the harness from the harness guide.

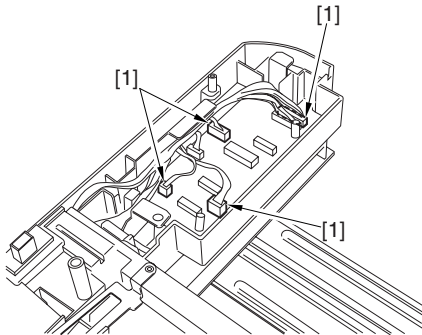

Figure 3-8-16

- 2) Remove the 2 screws [2], and detach the paper feeder pickup assembly [3].

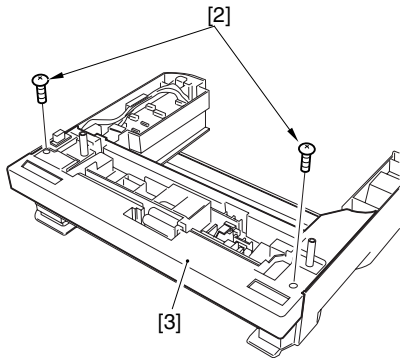

Figure 3-8-17

- 3) Remove the 4 screws [4] and the grounding wire [5]; then, detach the pickup motor assembly [6].

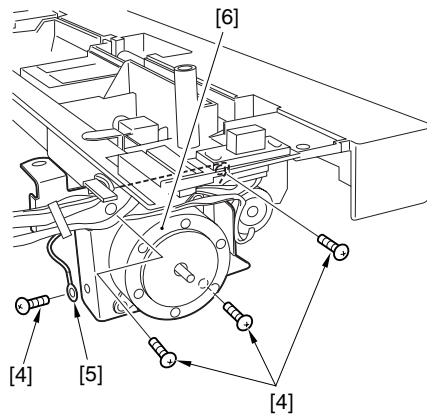

Figure 3-8-18

- 4) Remove the pickup roller [7]. (See III-A-1 'Removing the Cassette Pickup Roller.')
- 5) Holding the lock knob [8], slide the roller shaft [9] in the direction indicated in the figure.

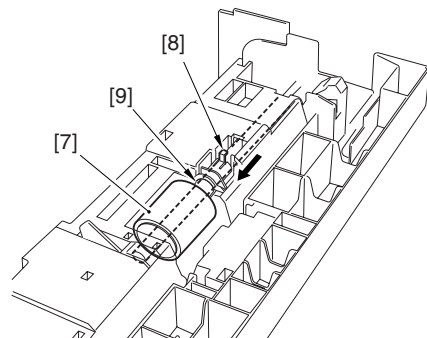

Figure 3-8-19

- 6) Remove the gear [10], and detach the paper feeder pickup clutch [11].

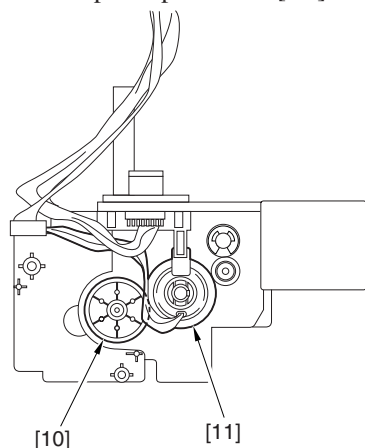

Figure 3-8-20

2. Removing the paper feeder pickup motor

- 1) Remove the paper feeder pickup assembly. (See VIII-C-1 'Removing the Paper Feeder Pickup Clutch.')
- 2) Remove the 2 screws [1], and detach the paper feeder pickup motor [2].

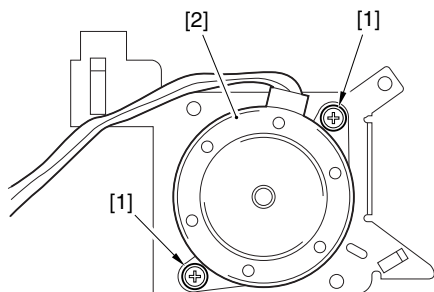

Figure 3-8-21

D. PCBs

1. Removing the paper feeder controller PCB

- 1) Remove the top plate.
- 2) Disconnect all connectors from the paper feeder controller PCB [1].
- 3) Remove the 2 screws [2], and slide the paper feeder controller PCB [1] to detach.

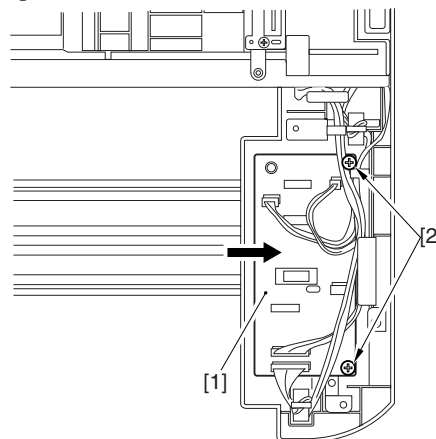

Figure 3-8-22

CHAPTER 4

TROUBLESHOOTING

I. INTRODUCTION	4-1	VII. STANDARDS AND	
II. TROUBLESHOOTING IMAGE		ADJUSTMENTS.....	4-31
FAULTS	4-10	VIII. MAINTENANCE AND	
III. MEASURES AGAINST JAMS	4-17	INSPECTION	4-38
IV. FEEDING FAULTS.....	4-21	IX. ARRANGEMENT OF ELECTRICAL	
V. MALFUNCTIONS	4-23	PARTS	4-43
VI. CORRECTING A FAULT STATUS			
CONDITION	4-25		

I. INTRODUCTION

A. Troubleshooting Flow Chart

A fault occurring in the Printer is identified as being either of the following five: image fault, jam, feeding fault, malfunction, error status.

If a fault occurs, isolate its cause using the flow chart, and then take the appropriate action give for the cause while keeping the following in mind:

- When measuring the voltage between terminals of a connector, be sure to find out if the connector has poor contact.
- When handling a PCB, be sure to touch a metal area of the Printer to be rid of static charges, thereby preventing static damage to the PCBs.
- The Printer's laser/scanner unit cannot be adjusted in the field. Do not attempt to disassemble it.

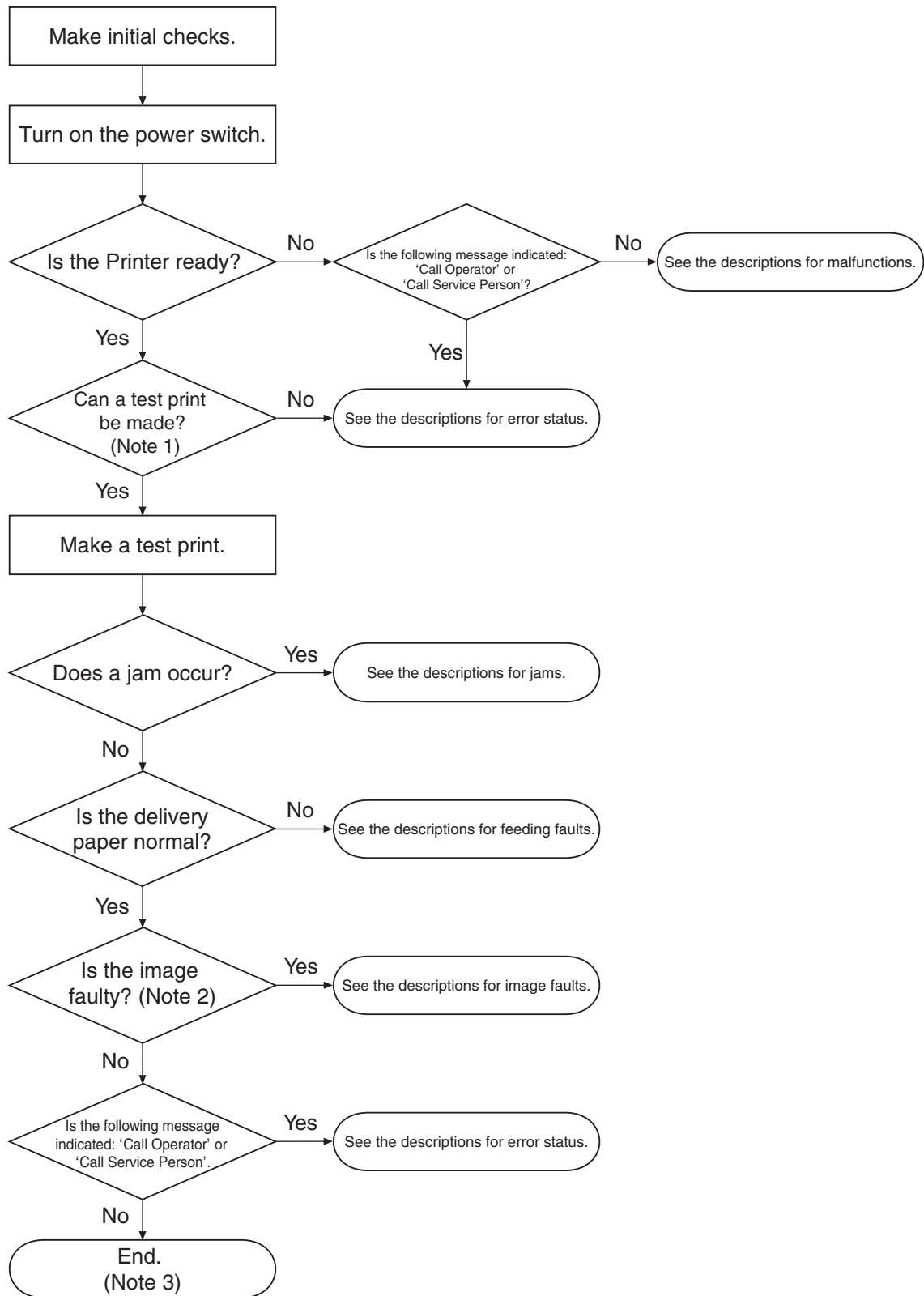

Figure 4-1-1

-
- Notes:**
1. When making a test print, be sure to use the same source of paper used when the fault occurred. If the source is not known, try all sources to reproduce the symptom.
 2. At times, the faulty image in question may not occur during test printing. If so, print from an external device, and take a guess in identifying the location of the fault; then, follow the troubleshooting steps to identify the cause.
 3. If abnormal noise is heard during the wait period or during printing operation, see the descriptions for malfunctions.
-

B. Making Initial Checks

Before starting troubleshooting steps, make the following checks; if a fault is discovered, correct it and then advise the user on how to avoid it:

1. Installation environment

- a. The power supply voltage is $\pm 10\%$ of the rated voltage.
- b. The Printer is kept level.
- c. The ambient temperature is between 7.5°C to 32.5°C and the humidity is between 5% and 90%.
- d. The Printer is not in an area subject to ammonium gas or high temperature/humidity (e.g., near water faucet, water boiler, humidifier). Nor is it in a cold area or near a source of fire or dust.
- e. The Printer must not be in an area subject to the direct rays of the sun. As necessary, advise the user to provide curtains.
- f. The room must be well ventilated.
- g. The power plug is securely connected to the Printer and the power outlet.

2. Types of paper

- a. The paper used must be of a type recommended and suited to the Printer.
- b. The paper must not be moist.

3. Paper

- a. The source of paper must have paper (not in excess of a indicated amount).
- b. The paper must be correctly placed against the pickup slot.

4. EP-65 cartridge

The cartridge must be correctly fitted to the Printer.

5. Condensation

If a Printer is brought in from a cold to warm place, its inside can start to develop condensation, triggering various problems; for example,

- On the optical system (6-face mirror, reflecting mirror, lens), it can cause light images (the photosensitive drum tends to be cold, causing the electrical resistance of its photoconducting layer to be high).

If condensation is noted, dry wipe the parts, or leave the Printer alone (powered) for 10 to 20 min.

The same is true of the cartridge. Do not open the cartridge without allowing it to become used to the room temperature (1 to 2 hr) before taking it out of its package.

C. Test Print

Test printing takes either of two forms: engine test printing or controller test printing. If a fault occurs in the Printer, make a test print to identify the symptom.

1. Engine test printing

The Printer has a pattern consisting of horizontal lines (at intervals of about 0.6 mm). The Test Print switch is found at the rear of the Printer (Figure 1-4-2). After making sure that the photosensitive drum is at rest and the Printer is in standby state, press the switch once to generate a single test pattern. Hold down the switch to generate test patterns in sequence.

A source of paper may be selected for test printing. If the selected source is without paper, the internal cassette will be used.

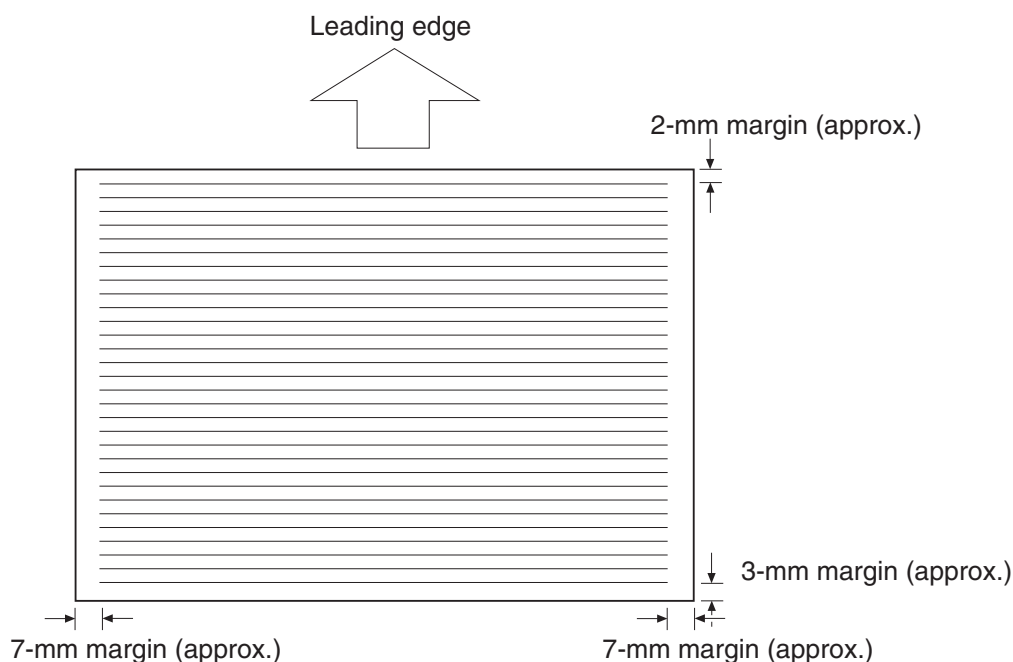

Figure 4-1-2

2. Controller test printing

The following items can be by selecting and executting a TEST MENU:

- SHOW PAGE COUNT

Indicates the total number of pages printed; according to paper size, i.e., small or large. The page count prints in the TEST PRINT.

- TEST PRINT

Make a TEST PRINT. The Test Print lists the printing enviornment setting and also displays the graphic and text printing capabilities. (See to Figure 4-1-3)

- PRINT PS FONTS

Available only after the Translator Module A-65 for Adobe PostScript Level 3 module is installed. Prints the PS demonstration page.

- PRINT PCL FONTS

Prints the PCL Font list.

- **PRINT JOB LOG**
Indicates a job log list showing the most recent 55 jobs.
- **CONTINUOUS TEST**
Makes continuous Test Prints.
(The printer back to READY key after SHIFT key and ENTER key to cancel CONTINUOUS TEST.)
- **PRINT EN CONFIG**
Prints the Ethernet configuration page.
- **CLEANING PAGE**
Prints the cleaning page used to clean the fixing roller.
Refer to page 1-23 for the details.

<How to Use>

- 1) Press the Go key so that the Printer enters off-line state.
- 2) Press the Menu key, and then hold down the Item key until the status indicator panel indicates 'TEST MENU'.
- 3) Press the Enter key to execute test printing.
- 4) At the end, press the Go key so that the Printer enters on-line status.

<TEST PRINT>

Canon Inc., LBP-2000 Printer Configuration Page



[1] TEST MENU
SHOW PAGE COUNT
TEST PRINT
PRINT PS FONTS
PRINT PCL FONTS
PRINT JOB LOG
CONTINUOUS TEST
PRINT EN CONFIG
CLEANING PAGE

[5] CONFIG MENU
JAM RECOVERY = OFF
AUTOCONT = ON
DENSITY = 7
PWRSV = 15 MIN
ECONOMY MODE = OFF
REFINE = ON

[12] JOB LOG MENU
AUTO PRINT LOG PER 50 JOBS = NO
JOB LOG FULL = WARNING
GMT DIFFERENTIAL TIME = 0.0
DAYLIGHT SAVING = OFF

[2] PCL MENU
RESOLUTION = 600
COPIES = 1
PAGESIZE = LETTER
ORIENTATION = PORTRAIT
FORM = 60LINES
FNTRC = INTERNAL
FONTNUM = 0
PT.SIZE = 12.00
PITCH = 10.00
SYMSET = ROMAN-8
AUTO CR = OFF
WIDE A4 = OFF
OVERRIDE = OFF

[6] SHUTDOWN MENU
SHUTDOWN

[13] JOB CONTROL MENU
JOB SECURING TIME = 2 HR
PRINT W/ USER ID& PASSWORD =OFF

[3] PS MENU
RESOLUTION = 600
COPIES = 1
PRINT ERRS = OFF

[7] PARALLEL MENU
PERSONALITY = AUTO
BIDIRECTION = ON
I/O TIMEOUT = 15

[14] INSTALLED OPTIONS
CASSETTE2
PS
ETHERNET
DISK
FLASH

TOTAL MEMORY = 8 MB
DISK SIZE = 9585 MB
DISK FREESPACE = 9581 MB

[4] FEEDER MENU
FEED = CASSETTE1
TRAY SWITCH = ON
MANUAL = OFF
MPT SIZE = LETTER

[8] USB MENU
PERSONALITY = AUTO
I/O TIMEOUT = 15

[15] PRINTER DETAILS
2001/01/01 00:00:33
CODE LEVELS
CTL V2.01-E2 US 2001/08/09
Engine Version 1.25
Serial Number 1000000015
PCL PeerlessPrint5-E PP5E V1.5.0
PCLXL PeerlessPrintXL PPXL V1.2.0
PS 1.19
EN 0.08
PSIO 3.03 04/01/97
PAGE COUNT = 78
SMALL COUNT = 78
LARGE COUNT = 0

[8] ETHERNET MENU
PERSONALITY = AUTO
I/O TIMEOUT = 15
IP ADDRESS = 192.168.0.215
SUBNET MASK = 0.0.0.0
GATEWAY ADDRESS = 0.0.0.0
MAC ADDRESS = 00:00:85:14:C0:5F

[10] LANGUAGE MENU
LANG = ENGLISH

[11] RESET MENU
RESET = MENU
RESET = FONTS
RESET = FORMS
RESET = STORED JOBS
RESET = JOB LOG
RESET = ERROR LOG
RESET = JAM LOG

Figure 4-1-3

The Configuration Page shown here is for a printer with the optional print server, hard disk, PS module, Flash ROM, and additional RAM memory installed.

[1] TEST MENU

Displays the test menu options.

[2] PCL MENU

Show the PCL print job settings, as determined by the PCL MENU options.

[3] PS MENU(Only displayed if the optional Adobe PostScript 3 Module A-65 is installed)

Displays the PostScript print job settings, as determined by the PS MENU options.

[4] FEEDER MENU

Displays the settings for the paper feed options for the printer, as determined by the FEEDER MENU options.

[5] CONFIG MENU

Displays the printer configuration as determined by the CONFIG MENU options.

[6] SHUTDOWN MENU

Displays the menu option used to shutdown the printer, before turning it off.

[7] PARALLEL MENU

Displays the parallel interface settings, as determined by the PARALLEL MENU options. If the optional PostScript module is installed, you will see the settings for automatic personality switching on the parallel port.

[8] USB MENU

Displays the USB interface settings, as determined by the USB MENU options. If the optional PostScript module is installed, you will see the settings for automatic personality switching on the USB port.

[9] ETHERNET MENU(Only displayed if the optional print server is installed.)

Displays the Ethernet interface settings, as determined by the ETHERNET MENU options. If the optional Post Script module is installed, you will see the settings for automatic personality switching on the print server.

[10] LANGUAGE MENU

Displays the language setting.

[11] RESET MENU

Displays the reset menu options.

[12] JOB LOG MENU

Displays the job log settings, as determined by the JOB LOG MENU options.

[13] JOB CONTROL MENU

Displays the job control settings, as determined by the JOB CONTROL MENU options.

[14] INSTALLED OPTIONS

Displays a list of the options installed on the printer and the total memory.

[15] PRINTER DETAILS

Displays the printer ROM DIMM version, version numbers of any installed options, and the page counts.

II. TROUBLESHOOTING IMAGE FAULTS

If the cause of the symptom is identified as being an 'image fault' in reference to the flow chart (Figure 4-1-1), isolate the cause as follows and take the appropriate action:

- 2-1 **Light:** The output is obviously too light.
- 2-2 **Dark:** The output is obviously too dark.
- 2-3 **Blank:** The output is blank.
- 2-4 **Solid:** The output is solid black.
- 2-5 **Dots:** The output has dots (as if splashed over the face).
- 2-6 **Soiled back:** The output has a soiled back.
- 2-7 **Black vertical line:** The output has black vertical lines.
- 2-8 **Black horizontal line:** The output has black horizontal lines.
- 2-9 **Soiled face:** The face of the output is soiled.
- 2-10 **White spots:** The output has images with white spots.
- 2-11 **White vertical line:** The output has white vertical lines.
- 2-12 **White horizontal line:** The output has white horizontal lines.
- 2-13 **Fixing fault:** The output has an image with an unstable toner deposit.
- 2-14 **Distorted image:** The output has a distorted image.
- 2-15 **Image splash:** The output has an image in which toner is splashed around characters.
- 2-16 **Image wobble:** The output has wobbling images.

2-1. Light

<Possible Causes>

1. The image density setting is not correct.
Action: Operate the external device, and adjust the image density.
2. Open the upper cover in the middle of printing operation, and take out the EP cartridge. Check the toner image on the surface of the photosensitive drum. If the toner image is not fully transferred to the paper, go to step 5. If the tone image on the surface of the photosensitive drum is too light as is, go to step 6. If the cartridge must be left outside the Printer after checking the toner image, be sure to keep it in a protective bag or cover it with paper.
3. The contact of the leaf spring for the transfer charging roller and the contact of the transfer charging roller shaft are faulty.
Action: If dirt is found, clean the contact. If the problem is not corrected after cleaning, or deformation or damage is found, replace the faulty part.
4. The transfer charging roller is deformed/worn.
Action: Replace the transfer charging roller.
5. The contact for the transfer charging roller on the DC controller PCB and the contact of the leaf spring for the transfer charging roller are poor.
Action: If dirt is found, clean the contact. If the problem is not corrected after cleaning, or if deformation or wear is found, replace the faulty part.
6. The laser/scanner unit is faulty.
Action: Replace the laser/scanner unit.
7. The DC controller PCB is faulty.
Action: Replace the DC controller PCB.

2-2. Dark

<Possible Causes>

1. The image density setting is not correct.
Action: Operate the external device to adjust the image density.
2. The contact of the leaf spring for the drum ground and the contact of the cartridge are poor.
Action: If dirt is found, clean the contact. If the problem is not corrected after cleaning, or deformation or damage is found, replace the faulty part.
3. The contact of the leaf spring for the primary bias and the contact of the cartridge are poor.
Action: If dirt is found, clean the contact. If the problem is not corrected, or deformation or damage is found, replace the faulty part.
4. The contact for the primary bias on the DC controller PCB and the contact of the leaf spring for the primary bias are poor.
Action: If dirt is found, clean the contact. If the problem is not corrected after cleaning, or damage or wear is found, replace the faulty part.
5. The laser/scanner unit is faulty.
Action: Replace the laser/scanner unit.
6. The DC controller PCB is faulty.
Action: Replace the DC controller PCB.

2-3. Blank

<Possible Causes>

1. The protrusion for opening/closing the laser shutter of the cartridge is damaged.
Action: Replace the cartridge.
2. The laser shutter arm or the laser shutter has poor operation or is damaged.
Action: Check the movement. If not smooth, or damage is found, replace the faulty part.
3. The contact of the leaf spring for developing bias and the contact of the cartridge are faulty.
Action: If dirt is found, clean the contact. If the problem is not corrected after cleaning, or deformation or damage is found, replace the faulty part.
4. The contact for the developing bias on the DC controller PCB and the contact of the left spring for the developing bias are poor.
Action: If dirt is found, clean the contact. If the problem is not corrected after cleaning, or deformation or damage is found, replace it with a faulty part.
5. The DC controller PCB is faulty.
Action: Replace the DC controller PCB.

2-4. Solid black

<Possible Causes>

1. The contact of the leaf spring for the primary bias and the contact of the cartridge are faulty.
Action: If dirt is found, clean the contact. If the problem is not corrected after cleaning, or deformation or damage is found, replace the faulty parts.
2. The contact for the primary bias on the DC controller and the contact of the cartridge are poor.
Action: If dirt is found, clean the contact. If the problem cannot be corrected after cleaning, or deformation or damage is found, replace the faulty part.
3. The primary charging roller is faulty.
Action: Replace the cartridge.
4. The DC controller PCB is faulty.
Action: Replace the DC controller PCB.

2-5. Dots

<Possible Causes>

1. The contact of the leaf spring for the static eliminating brush and the contact of the leaf spring for the static eliminating brush are faulty.
Action: If dirt is found, clean the contact. If the problem is not corrected after cleaning, or deformation or damage is found, replace the faulty part.
2. The transfer charging roller is deformed/worn.
Action: Replace the transfer charging roller.
3. The contact for the leaf spring for the transfer charging roller and the contact of the transfer charging roller shaft are poor.
Action: If dirt is found, clean the contact. If the problem is not corrected after cleaning, or deformation or image is found, replace the faulty part.
4. The contact for the transfer charging roller on the DC controller PCB and the contact of the leaf spring for the transfer charging roller are poor.
Action: If dirt is found, clean the contact. If the problem cannot be corrected after cleaning, or deformation or damage is found, replace the faulty part.
5. The DC controller PCB is faulty.
Action: Replace the DC controller PCB.

2-6. Soiled back

<Possible Causes>

1. The paper is soiled.
Action: Replace the paper with paper fresh out of package. At the same time, advise the user on the correct method of storing paper.
2. The setting and the type of paper used do not match.
Action: Check the selected fixing mode, and change it to suit the type of paper used.
3. There is dirt at specific intervals (cassette pickup roller, manual fee pickup roller, registration roller, transfer charging roller, delivery roller).
Action: Identify the soiled roller by referring to Tale 4-2-1, and clean it. If the dirt cannot be removed, replace the roller.
4. The fixing assembly is faulty.
Action: Replace the fixing assembly.

2-7. Black vertical lines

<Possible Causes>

1. There is a scratch in the peripheral direction of the photosensitive drum.
Action: Replace the cartridge.
2. There is a scratch on the fixing roller.
Action: Remove the cause of the scratch, and replace the fixing assembly.

2-8. Black horizontal lines

<Possible Causes>

1. There is a scratch across the photosensitive drum.
Action: Replace the cartridge.
2. The fixing roller is soiled, deformed, or worn.
Action: Replace the fixing assembly.

2-9. Soiled face

<Possible Causes>

1. The paper is soiled.
Action: Replace the paper with paper fresh out of package. At the same time, advise the user on the correct method of storing paper.
2. The delivery roller is soiled.
Action: Clean the soiled area. If the dirt cannot be removed, replace the delivery roller.
3. There is dirt at specific intervals (separation roller, transfer charging roller, fixing roller, cartridge).
Action: Identify the soiled roller by referring to Table 4-2-1, and clean it. If the dirt cannot be removed, replace the roller.

2-10. White spots

<Possible Causes>

1. The cartridge is running out of toner.
Action: Remove the cartridge from the Printer, and shake it as instructed in Chapter 1; then, fit it back into the machine. If the problem is not corrected, replace the cartridge.
2. The transfer charging roller is soiled or deformed.
Action: Replace the transfer charging roller.
3. The contact of the toner level sensor and the contact of the cartridge are poor.
Action: If dirt is found, clean the contact. If the problem is not corrected after cleaning, or deformation or damage is found, replace the faulty part.
4. The photosensitive drum, developing cylinder, or toner level sensor is faulty.
Action: Replace the cartridge.
5. The DC controller PCB is faulty.
Action: Replace the DC controller PCB.

2-11. White vertical lines

<Possible Causes>

1. The cartridge is running out of toner.
Action: Remove the cartridge from the Printer, and shake it as instructed in Chapter 1; then, fit it back into the Printer. If the problem is not corrected, replace the cartridge.
2. There is a scratch in the peripheral direction of the photosensitive drum.
Action: Replace the cartridge.
3. The developing cylinder is faulty.
Action: Remove the cause of the scratch, and replace the cartridge.
4. The laser outlet of the Printer or the laser inlet of the cartridge is coated with foreign matter.
Action: Remove the foreign matter.
5. There is a scratch on the fixing roller.
Action: Remove the cause of the scratch, and replace the fixing assembly.
6. The mirror inside the laser/scanner unit is soiled.
Action: Replace the laser/scanner unit.

2-12. White horizontal lines

<Possible Causes>

1. There is a horizontal scratch across the photosensitive drum.
Action: Replace the cartridge.
2. There is a scratch on the fixing roller.
Action: Remove the cause of the scratch, and replace the fixing assembly.

2-13. Fixing faulty.*<Possible Causes>*

1. The setting and the type of paper used do not match.
Action: Correct the setting to suit the type of paper used.
2. The nip of the fixing assembly is not as indicated.
Action: Replace the fixing assembly.
3. The fixing roller is soiled, defomed, or worn.
Action: Replace the fixing assembly.
4. The thermistor has deteriorated.
Action: Replace the fixing assembly.

2-14. Distorted image*<Possible Causes>*

1. The contact of the connectors of the laser/scanner unit is poor.
Action: Connect the following connectors firmly: J907, J908, J911.
2. The contact of the connector of the DC controller PCB is poor.
Action: Connect the following connectors firmly: J102, J106.
3. The laser/scanner unit is faulty or is mounted wrongly.
Action: Replace the laser/scanner unit.
4. The DC controller PCB is faulty.
Action: Replace the DC controller PCB.

2-15. Image splash*<Possible Causes>*

1. The transfer charging roller is soiled.
Action: Clean the transfer charging roller. If the dirt cannot be removed, replace the roller.

2-16. Image wobble

<Possible Causes>

1. The setting and the type of paper used do not match.
Action: Correct the setting to suit the type of paper used.

2. The transfer charging roller is faulty.
Action: Replace the transfer charging roller.

Table 4-2-1

Dirt or White Spots at Specific Intervals in the Images

Location	Diameter (mm; approx.)	Interval (mm; approx.)	Symptom			
			Dirt	White spot	Soiled back	Fixing fault
Cassette pickup roller	36	113	○			
Paper feeder feeding roller	14	44	○			
Registration roller	16	50	○		○	
Primary charging roller	17	53	○	○		
Photosensitive drum	30	97	○	○		
Developing cylinder	20	50	○	○		
Transfer charging roller	16	55		○	○	
Fixing roller	31	97	○	○		○
Pressure roller	25	79			○	

III. MEASURES AGAINST JAMS

The Printer's paper path can broadly be divided into the following 5 blocks:

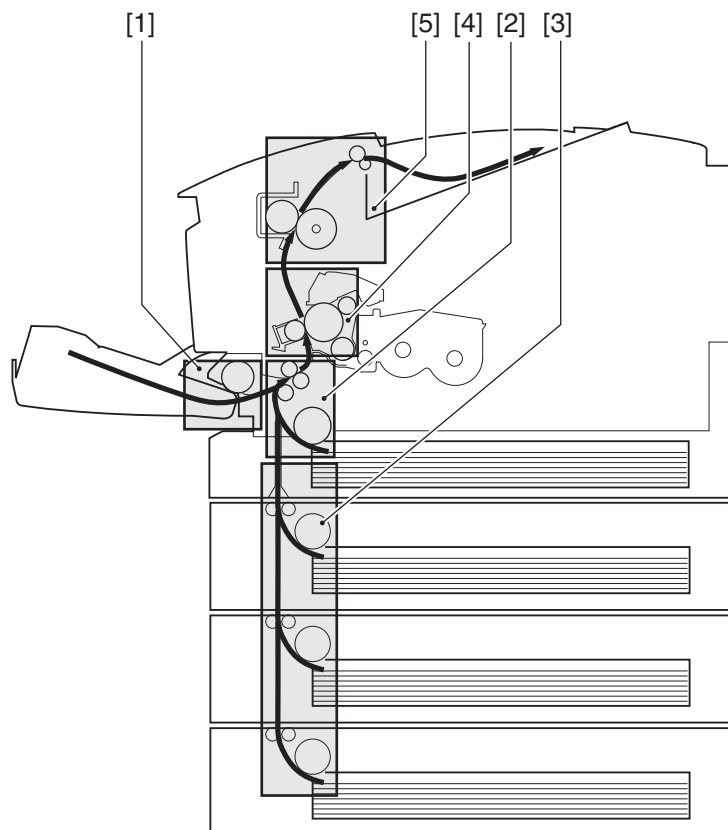

[1] Multifeder pickup block
 [3] Paper feeder pickup block
 [5] Fixing/delivery block

[2] Cassette pickup block
 [4] Transfer/feeding block

Figure 4-3-1

If the fault in question has been identified as being a jam using the flow chart (Figure 4-1-1), find the location and then isolate the cause.

3-1. Multifeder pickup block

<Possible Causes>

1. The curling of the paper is appreciable.
Action: Correct the curling. Thereafter, advise the user to correct curling before feeding paper.
2. The multifeder pickup roller is worn, deformed, or soiled.
Action: If the multifeder pickup roller is soiled, clean it. If label sheets or the like is used often, leaving dirt and causing pickup faults, advise the user to use the manual feed tray cleaning tool. (For instructions on how to use the tool, see VII-4 'Manual Feed Pickup Roller' in Chapter 1.) If wear or deformation is found, replace it.

3. The lever of the multifeeder sensor does not move smoothly, or is damaged or deformed.
Action: Fit it so that it moves smoothly. If damaged or deformed, replace it.
4. The position of the cam (manual feed roller) is wrong.
Action: Check to be sure that the manual feed roller is correctly mounted. (See IV-B-2 'Removing the Manual Feed Pickup Roller' in Chapter 3.)
5. The gear is damaged.
Action: Remove the multifeeder pickup assembly, and check the gears. Replace any damaged gear.
6. The multifeeder pickup solenoid (SL101) is faulty.
Action: Disconnect the connector J106 of the multifeeder pickup solenoid. Measure the resistance between the connectors J905-1 and J906-2 on the harness side. If not about $65 \pm 6.5\Omega$ replace the multifeeder pickup solenoid.
7. The DC controller PCB is faulty.
Action: Replace the DC controller PCB.

3-2. Cassette pickup block

<Possible Causes>

1. The paper is bent.
Action: Replace the paper.
2. The cassette pickup roller or the cassette separation pad is worn or deformed.
Action: If wear or deformation is found, replace it. Be sure to replace the cassette pickup roller and the cassette separation pad at the same time.
3. A part in the drive mechanism of the pickup assembly is damaged.
Action: Remove the drive assembly, and replace any damaged part.
4. The cassette pickup clutch (CL101) is faulty.
Action: Disconnect the connector J906 of the cassette pickup clutch. Measure the resistance between the connectors J906-1 and J906-2 on the harness side. If not about $144 \pm 14.4\Omega$ replace the cassette pickup clutch.
5. The DC controller PCB is faulty.
Action: Replace the DC controller PCB.

3-3. Paper feeder pickup block

<Possible Causes>

1. The paper is bent.
Action: Replace the paper.
2. The cassette pickup roller or the cassette separation pad is worn or deformed.
Action: If wear or deformation is found, replace it. Be sure to replace the cassette pickup roller and the cassette separation pad at the same time.

3. A part in the pickup drive assembly is damaged.
Action: Remove the pickup drive assembly, and replace any damaged part.
4. The paper feeder pickup motor (M201) is faulty.
Action: Replace the paper feeder pickup motor.
5. The paper feeder pickup clutch (CL201) is faulty.
Action: Disconnect the connector J3 of the paper feeder pickup clutch. Measure the resistance between the connectors J3-1 and J3-2 on the harness side. If not about $192 \pm 19.2\Omega$ replace the paper feeder pickup clutch.
6. The paper feeder controller PCB is faulty.
Action: Replace the paper feeder controller PCB.
7. The DC controller PCB is faulty.
Action: Replace the DC controller PCB.

3-4. Transfer/feeding block

<Possible Causes>

1. The registration roller is soiled or worn.
Action: If the registration roller is soiled, clean it. If worn, replace it.
2. The registration roller does not rotate smoothly.
Action: Replace the bushing, and make sure that the roller rotates smoothly.
3. The transfer charging roller does not rotate smoothly.
Action: Replace the bushing. If the gear is worn, replace the gear.
4. The lever of the registration paper sensor does not move smoothly. Or, it is worn or deformed.
Action: Fit it so that it moves smoothly. If worn or damaged, replace it.
5. A part in the drive mechanism of the pickup assembly is damaged.
Action: Remove the drive mechanism, and replace any damaged part.
6. The registration clutch (CL102) is faulty.
Action: Disconnect the connector J905 of the registration clutch. Measure the resistance between the connectors J905-1 and J905-2 on the harness side. If not about $144 \pm 14.4\Omega$ replace the registration clutch.
7. The registration paper sensor (PI101) is faulty.
Action: Replace the registration paper sensor.
8. The DC controller PCB is faulty.
Action: Replace the DC controller PCB.

3-5. Fixing/delivery block

<Possible Causes>

1. The fixing roller does not rotate smoothly.
Action: Check the gear for wear or chipping. If a fault is found, replace the fixing assembly.
2. The fixing/separation claw is worn or damaged.
Action: Replace the fixing assembly.
3. The fixing roller or the pressure roller is deformed or scratched.
Action: Replace the fixing assembly.
4. The pressure (nip) of the pressure roller is not as indicated.
Action: Replace the fixing assembly.
5. The delivery sensor lever does not move smoothly or is damaged.
Action: Fit it so that it moves smoothly. If damaged, replace it.
6. The delivery roller is worn.
Action: Replace the delivery roller.
7. The delivery sensor (PI103) is faulty.
Action: Replace the delivery sensor.

IV. FEEDING FAULTS

If the symptom has been identified as a feeding fault according to the flow chart (Figure 4-1-1), identify the location and correct the fault.

4-1. Double feeding

<Possible Causes>

1. The paper is not of a recommended type.
Action: Replace the paper. At the same time, advise the user to use paper of a recommended type.
2. If the fault is in the multifeeder tray, go to step 7.
3. The paper is not set correctly.
Action: Set the paper correctly in the cassette.
4. The paper retainer of the cassette is deformed.
Action: If the paper retainer of the cassette is deformed, replace it.
5. The cassette separation pad is worn or deformed.
Action: Replace the cassette separation pad. Be sure to replace the cassette pickup roller and the cassette separation pad at the same time.
6. The spring used to push up the cassette separation pad is faulty.
Action: Replace the spring.
7. The surface of the manual feeder separation pad is soiled or worn.
Action: Clean the multifeeder separation pad. If the problem is not corrected, replace it.

4-2. Wrinkling/bent leading edge

<Possible Causes>

1. The paper has curling.
Action: Advise the user to correct curling.
2. Execute test printing. Open the front cover before the paper enters the fixing assembly. If the paper has curling at this time, go to step 4.
3. The fixing roller/pressure roller is deformed or worn.
Action: If it is worn or deformed, replace the fixing assembly.
4. There is an accumulation of paper lint or dust on the registration roller or the feeding guide.
Action: Clean the soiled area.

4-3. Skew

<Possible Causes>

1. The paper is not set correctly.

Action: Set the paper against the paper guides at the left/right and the rear end of the cassette.

2. There is an accumulation of paper lint or dust on the registration roller or the feeding guide.

Action: Clean the soiled area.

3. The registration roller is deformed.

Action: If scratched or deformed, replace it.

V. MALFUNCTIONS

If the symptom has been identified as a malfunction according to the flow chart (Figure 4-1-1), take the following action:

5-1. AC power is absent.

<Possible Causes>

1. The rated voltage is not present at the power outlet.
Action: Advise the user that the rated voltage is not present at the power outlet.
2. The power cord is not connected to the Printer's power socket.
Action: Connect the power cord.
3. The power switch is faulty.
Action: Check the power switch to see if it is operating normally.
4. The power supply PCB is faulty.
Action: Replace the power supply PCB.

5-2. DC power is absent.

<Possible Causes>

1. AC power is not present.
Action: See 5-1 'AC power is absent.'
2. The overcurrent/over-voltage detection circuit has gone ON.
Action: Turn off and then on the power switch. If the problem is not corrected, find out the cause of activation of the overcurrent/over-voltage detection circuit on the DC controller PCB. Be sure to wait for 7 min or more after turning off the power switch before turning it on.
3. The power supply PCB is faulty.
Action: Replace the power supply PCB.
4. The wiring, DC loads, or DC controller PCB is faulty.
Action: Turn off the power switch, and check the wiring and DC load from the DC controller PCB onward. If a fault is found, replace it. If the wiring and the DC loads are free of a fault, replace the DC controller PCB.

5-3. Operating noise is heard, but the control panel is OFF.

<Possible Causes>

1. A connector has poor contact.
Action: Connect the connector J6 of the video controller PCB correctly. If the problem is not corrected, check J6 and J104 for electrical continuity.
2. The control panel is faulty.
Action: Replace the control panel.

5-4. Abnormal noise is heard from the fixing assembly.

<Possible Causes>

1. The fixing roller gear is not mounted correctly.

Action: If chipping is discovered on the fixing roller gear or the drive gear, replace the drive gear or fixing assembly.

2. The fixing assembly is faulty.

Action: Replace the fixing assembly.

VI. CORRECTING A FAULT STATUS CONDITION

If the cause has been determined to be a “fault status condition” in relation to the Troubleshooting Flow Chart (Figure 4-1-1), be sure to go through the following:

- 6-1. ‘E000 CALL FOR SERVICE’ (fault in fixing assembly)**
‘E001 CALL FOR SERVICE’ (low temperature error)
‘E003 CALL FOR SERVICE’ (temperature error)
‘E808 CALL FOR SERVICE’ (fuser drive circuit error)

Note: If ‘E000’, ‘E001’, ‘E003’ or ‘E808’ is indicated, the information on the fault in the fixing assembly is retained in the NVRAM on the DC controller PCB even after the power switch has been turned off and then on. (Whether or not the code is indicated depends on the reading of the fixing roller temperature.) If the code is indicated, be sure to clear the fault information using service mode. (See C. of VIII. in Chapter 1.)

<Possible Causes>

1. The fixing assembly is not properly mounted.
Action: Turn off the power, and correct the mounting of the fixing assembly. Then, turn the power back on.
2. The connector has poor contact.
Action: Turn off the power, and check the wiring and connector from the power supply PCB/ DC controller PCB to the fixing assembly.
3. The fixing assembly drive circuit on the power supply PCB is faulty.
Action: Replace the power supply PCB.
4. The DC controller PCB is faulty.
Action: Replace the DC controller PCB.

6-2. ‘E011 CALL FOR SERVICE’ (main motor fault)

<Possible Causes>

1. The connector of the main motor (M101) drive signal has poor contact.
Action: Correct the connection of the connector J903 of the main motor and the connector J106 on the DC controller PCB.
2. The main motor (M101) is faulty.
Action: Replace the main motor.
3. The DC controller PCB is faulty.
Action: Replace the DC controller PCB.

6-3. 'E110 CALL FOR SERVICE' (scanner unit fault)

<Possible Causes>

1. The connector of the BD signal line has poor contact.
Action: Correct the connection of the connector J908 on the BD PCB and the connector J102 on the DC controller PCB.
2. The laser/scanner unit fault (BD) signal is not generated properly.
Action: Replace the laser/scanner unit.
3. The connector of the scanner motor (M102) drive signal line has poor contact.
Action: Correct the connection of the connector J907 on the scanner driver PCB and the connector J102 on the DC controller PCB. If the fault cannot be corrected, replace the scanner unit.
4. The DC controller PCB is faulty.
Action: Replace the DC controller PCB.

6-4. 'E676 CALL FOR SERVICE' (communication error)

<Possible Causes>

1. A communication error occurred between the video controller PCB and the DC controller PCB.
Action: Reconnect the flexible cable between the video controller and the DC controller. If not, replace it. Then replace the DC controller PCB. If the fault cannot be corrected, replace the video controller PCB.

**6-5. '677/6F-61 CALL FOR SERVICE' (internal ROM error)
'677/6F-63 CALL FOR SERVICE' (internal RAM error)
'677/6F-7A CALL FOR SERVICE' (SRAM error)**

<Possible Causes>

1. The video controller PCB is faulty.
Action: Turn off the power switch, and then turn it on. If the problem is not corrected, replace the video controller PCB.

6-6. 'E805 CALL FOR SERVICE' (The heat discharge fan is faulty.)

<Possible Causes>

1. The connector of the heat discharge (FM101) drive signal line has poor contact.
Action: Connect the connector J109 of the DC controller PCB correctly.
2. The heat discharge fan (FM101) is faulty.
Action: Replace the heat discharge fan.
3. The DC controller PCB is faulty.
Action: Replace the DC controller PCB.

6-7. 'LOAD <SIZE>IN <TRAYS>' is indicated although paper of the selected size is inside the cassette.

<Possible Causes>

1. The cassette detecting lever is damaged.
Action: Replace the lever.
2. The cassette paper sensor is faulty.
Action: Replace the cassette paper sensor.
3. The DC controller PCB is faulty.
Action: Replace the DC controller PCB.
4. The video controller PCB is faulty.
Action: Replace the video controller PCB.

6-8. 'LOAD <SIZE> IN MANUAL' is indicated although paper of the selected size is in the multifeeder tray.

<Possible Causes>

1. The multifeeder paper detecting lever is damaged.
Action: Replace the lever.
2. The multifeeder paper sensor is faulty.
Action: Replace the multifeeder sensor.
3. The DC controller PCB is faulty.
Action: Replace the DC controller PCB.
4. The video controller PCB is faulty.
Action: Replace the video controller PCB.

6-9. 'TONER CART MISSING' is indicated in the presence of a cartridge.

<Possible Causes>

1. The contact of the Printer and the contact of the cartridge are poor.
Action: If dirt is found, clean the contact. If the problem is not corrected, or deformation or damage is found, replace the faulty part.
2. The cartridge is faulty.
Action: Replace the cartridge.
3. The DC controller PCB is faulty.
Action: Replace the DC controller PCB.
4. The video controller PCB is faulty.
Action: Replace the video controller PCB.

6-10. 'CASSETTE 1 MISSING' is indicated in the presence of a cassette.

<Possible Causes>

1. The paper size detecting switch lever of the cassette is damaged.
Action: Replace the paper size detecting switch.
2. The DC controller PCB is faulty.
Action: Replace the DC controller PCB.
3. The video controller PCB is faulty.
Action: Replace the video controller PCB.

6-11. 'CASSETTE X MISSING' is indicated in the presence of a cassette in the paper feeder (when a paper feeder is installed; X indicating the exact cassette).

<Possible Causes>

1. The paper size detecting switch lever of the cassette is damaged.
Action: Replace the paper size detecting switch.
2. The paper feeder controller PCB is faulty.
Action: Replace the paper feeder controller PCB.
3. The DC controller PCB is faulty.
Action: Replace DC controller PCB.
4. The video controller PCB is faulty.
Action: Replace the video controller PCB.

6-12. 'PRINTER OPEN' is indicated while the cover is closed.

<Possible Causes>

1. The right rail interlock lever is damaged.
Action: Replace the right rail interlock lever.
2. The right/left door switch is faulty.
Action: Replace the right/left door switch.
3. The DC controller PCB is faulty.
Action: Replace the DC controller PCB.
4. The video controller PCB is faulty.
Action: Replace the video controller PCB.

6-13. 'PAPER JAM' is indicated in the absence of a jam, and the Printer fails to be ready.**<Possible Causes>**

1. The registration paper sensor lever does not move smoothly. Or, it is damaged.
Action: Mount it so that it moves smoothly. If damaged, replace it.
2. The delivery sensor lever does not move smoothly. Or, it is damaged.
Action: Mount it so that it moves smoothly. If damaged, replace it.
3. The registration paper sensor (PI101) is faulty.
Action: Replace the sensor.
4. The delivery sensor (PI103) is faulty.
Action: Replace the sensor.
5. The DC controller PCB is faulty.
Action: Replace the DC controller PCB.
6. The video controller PCB is faulty.
Action: Replace the video controller PCB.

6-14. 'PS OPTION ERROR' is indicated after replacing the optional PS ROM.**<Possible Causes>**

1. The video controller PCB is faulty.
Action: Turn off the power switch, and then turn it on. If the problem is not corrected, mount the optional PS ROM once again. If the problem still is not corrected, replace the video controller PCB.

6-15. 'OPTION RAM ERROR' is indicated after replacing the optional RAM.**<Possible Causes>**

1. The video controller PCB is faulty.
Action: Turn off the power switch, and then turn it on. If the problem is not corrected, mount the optional RAM once again. If the problem is still not corrected, replace the video controller PCB.

6-16. 'OPTION ROM ERROR' is indicated after replacing the optional ROM.**<Possible Causes>**

1. The video controller PCB is faulty.
Action: Turn off the power switch, and then turn it on. If the problem is not corrected, mount the optional ROM once again. If the problem is still not corrected, replace the video controller PCB.

6-17. 'FLASH ERROR' is indicated after replacing the optional flash ROM.

<Possible Causes>

1. The video controller PCB is faulty.

Action: Turn off the power switch, and then turn it on. If the problem is not corrected, mount the optional flash ROM once again. If the problem is still not corrected, replace the video controller PCB.

6-18. 'PARALLEL INTERFACE ERROR' is indicated after power is turned off and then on.

<Possible Causes>

1. The menu settings are wrong.

Action: Correct the settings for PARALLEL MENU under USER MENU.

2. The parallel interface cable is not connected correctly.

Action: Correct the connection of the parallel interface cable.

3. The video controller PCB is faulty.

Action: Replace the video controller PCB.

6-19. 'USB INTERFACE ERROR' is indicated after the power is turned off and then on.

<Possible Causes>

1. The menu settings are wrong.

Action: Correct the settings for USB MENU under USER MENU.

2. The USB cable has poor connection.

Action: Correct the connection of the USB cable.

3. The video controller PCB is faulty.

Action: Replace the video controller PCB.

6-20. 'ETHERNET OPTION ERROR' is indicated after turning off and then on the power.

<Possible Causes>

1. The menu settings are wrong.

Action: Correct the settings of ETHERNET MENU under USER MENU.

2. The Ethernet cable is not connected securely.

Action: Correct the connection of the ethernet cable.

3. The built-in print server is faulty.

Action: Replace the built-in print server.

4. The video controller PCB is faulty.

Action: Replace the video controller PCB.

VII. STANDARDS AND ADJUSTMENTS

A. Making Mechanical Adjustments

1. Checking the pressure (nip) of the pressure roller

Caution: In the steps that follow, you will be asked to turn off the power switch while the Printer is in operation. Be sure to remove the option hard disk, if installed, before starting the steps; otherwise, turning off the power can damage the disk.

The Printer's fixing assembly is not designed to allow adjustment of the nip; nevertheless, fixing faults can occur if the nip is not appropriate.

Check the nip as follows:

- 1) Prepare an A4 or LTR solid black sheet using an EP cartridge, and take it to the field.
- 2) With the solid black side of the sheet facing upward, select a source of paper, and set the sheet inside.
- 3) Press the Test Print switch.
- 4) Turn off the power switch as soon as the leading edge of the sheet moves to the delivery tray. In about 10 sec, take out the sheet from the Printer.
- 5) Measure the width of the area with shiny toner (Figure 4-7-1), and check to make sure that it is as indicated:

- Middle (a): 2.9 to 4.6 mm
- Left/right (b, c): 3.5 mm or more
- Difference between left and right (|b - c|): 0.5 mm or less
- Difference between edge and middle (b - a, c - a): 0.5 mm or more

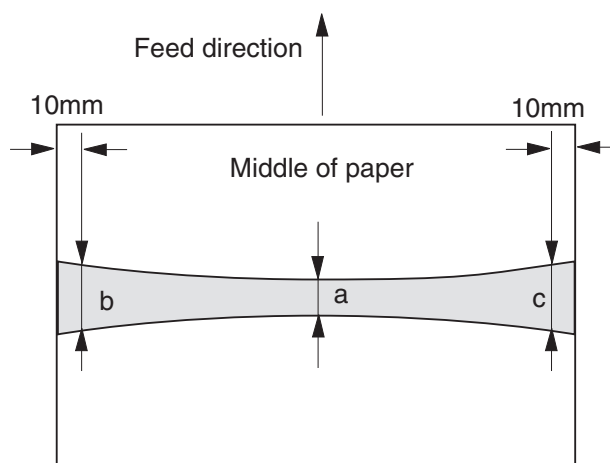

Figure 4-7-1

B. Making Electrical Adjustments

1. Adjusting the leading edge margin

VR101 (Figure 1-4-2) on the DC controller PCB is adjusted in the factory, not requiring adjustment in the field. If you have replaced the DC controller PCB in the field, however, be sure to make adjustments. If you have replaced the laser/scanner unit, on the other hand, make adjustments if the leading edge margin is not 2.0 ± 1.2 mm (check by making several test prints).

- 1) Remove the test print switch cover (Figure 1-4-2) at the rear of the Printer.
- 2) Set VR101 on the DC controller to the median index (± 0), and place A4 or LTR paper in the cassette. Then, press the test print switch to make several test prints.
- 3) Measure the distance (a) from the leading edge of the paper to the print pattern. (Figure 4-7-2)
- 4) Turn VR101 until the distance obtained in step 3 is 2.0 mm.
Turning VR101 clockwise moves the image in the direction of + (Figure 4-7-2), while turning it counterclockwise moves it in the direction of -; a single index is a shift of about 1.7 mm.
- 5) For instance, if the average reading is 3.7 mm, turn VR101 clockwise in the direction of - to make up for the difference of 1.7 mm. If the result is not as indicated, repeat steps 1) through 4).

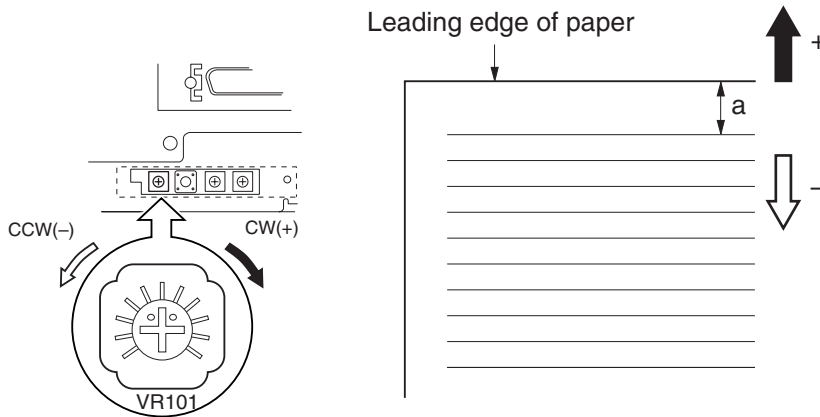

Figure 4-7-2

C. Copying the Counter Readings

If you have replaced the video controller PCB, be sure to perform the following work:

Caution: If you are mounting a hard disk (option), wait until you have copied the counter readings.

- 1) Remove the 2 EEPROMs (IC4, IC5) from the exiting video controller PCB.
- 2) Making sure that the cut-off faces down, mount the EEPROM to the new video controller PCB.

Caution: Be sure that the EEPROM is mounted at its appropriate position (by referring to where it was in the older PCB.)

- 3) Start the Service menu. (See C. 'Service Menu' under VIII. of Chapter 1.)
- 4) Copy the counter readings by going through the following flow of work:

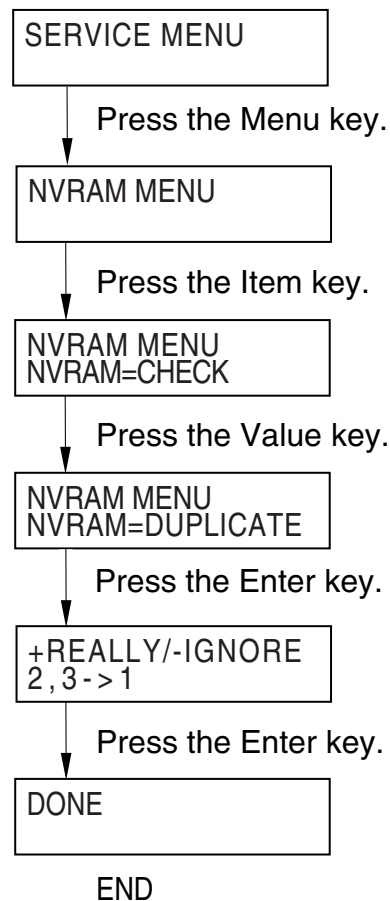

Figure 4-7-3

- 5) Press the Go key to end the Service menu.
- 6) Start the User menu, and select 'SHOW PAGE COUNT' under 'TEST MENU'; then, check to be sure that the counter readings are as they were before replacement.

D. Variable Resistors (VR), Light-Emitting Diodes (LED), Check Pins, Jumpers, and Switches by PCB

Of the VRs, LEDs, check pins, jumpers, and switches used in the Printer, those needed for servicing in the field are discussed.

Do not touch the VRs or check pins into indicated in the tables; they are for use at the factory only, and require special tools and high accuracy.

Notes: 1. Some LEDs emit dim light because of leakage current even while they are OFF. This is a normal condition and must be kept in mind.

2. VRs that may be used in the field ----- ●

VRs that must not be used in the field ----- ○

1. DC controller PCB

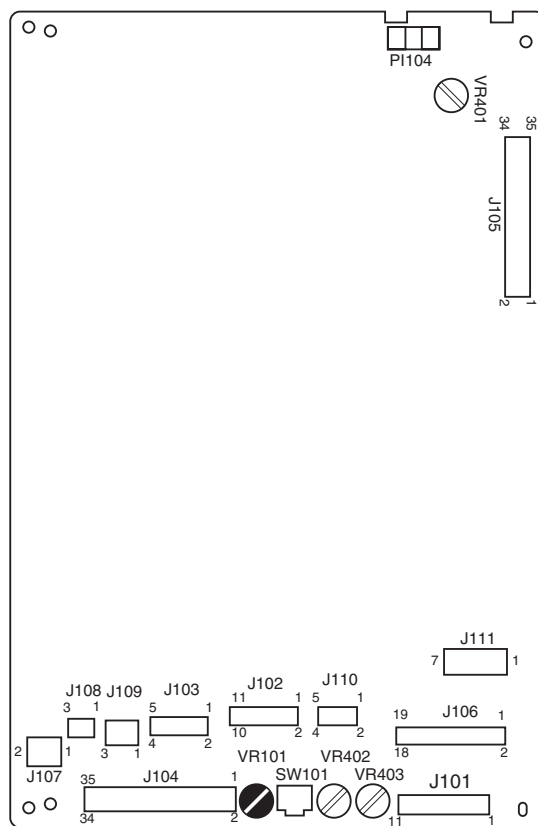

Figure 4-7-4

Table 4-7-1

Notation	Description
VR101	For adjusting leading edge adjustment
VR401	For adjustment in factory
VR402	For adjustment in factory
VR403	For adjustment in factory
SW101	Test Print switch

2. Video controller PCB

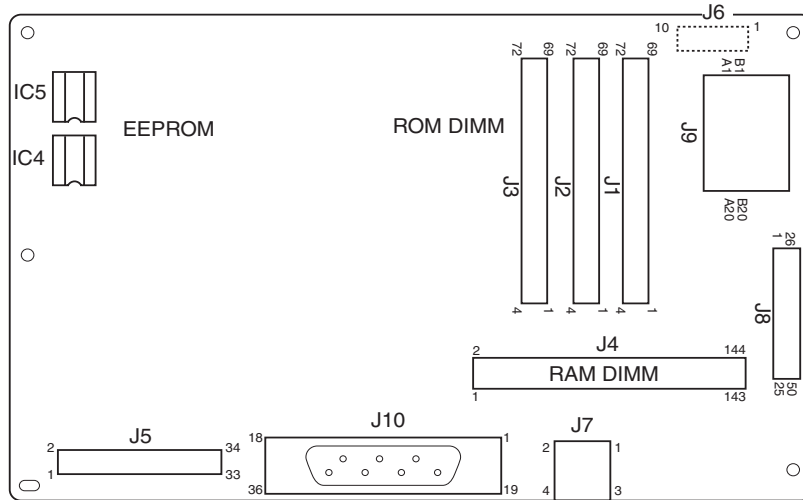

Figure 4-7-5

Note: If you must replace the video controller PCB, be sure to remove the following from the old PCB and mount them back to the new PCB: RAM DIMM, ROM DIMM (except program ROM), EEP-ROM (indicated by dashed lines). Then execute copying the counter readings in service menu. (See VII-C the Copying the Counter Readings in Chapter 4.)

3. Power supply PCB

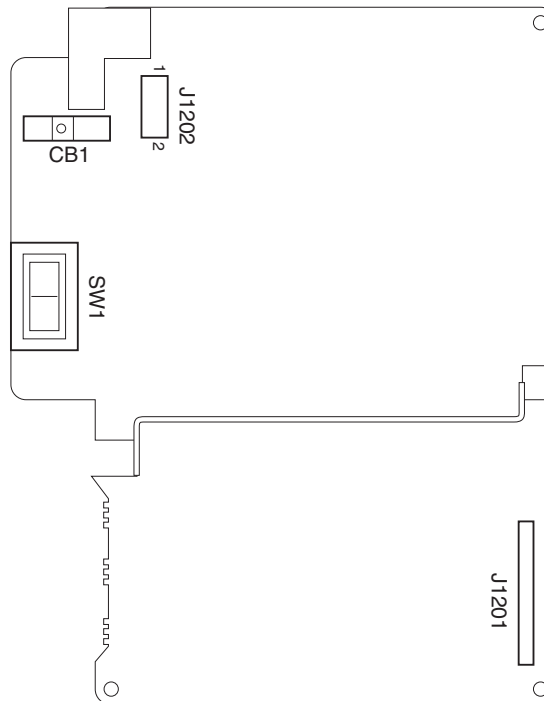

Figure 4-7-6

4. Control panel PCB

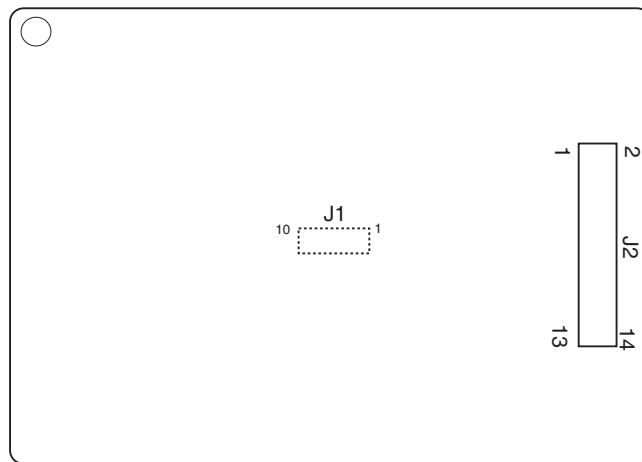

Figure 4-7-7

5. Built-in print server (option)

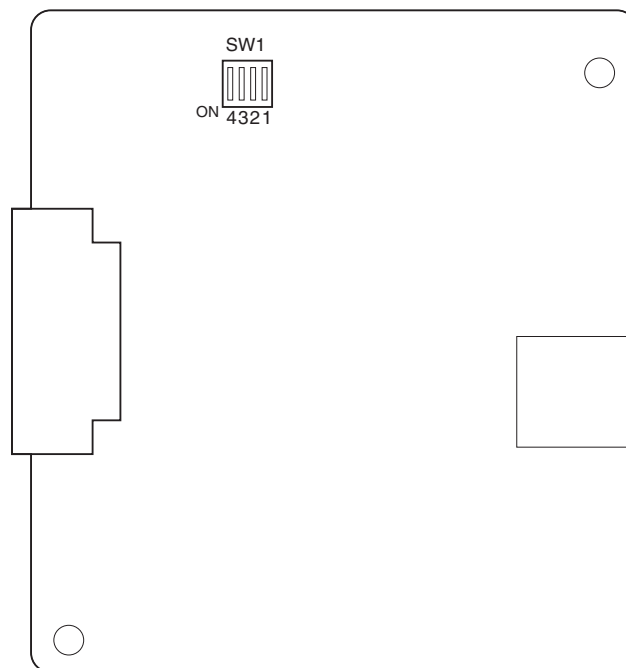

Figure 4-7-8

Table 4-7-2 shows the DIP switch settings.

Table 4-7-2

Switch	Description	Factory setting
Switch 1	ON : set all settings stored on the print server to factory settings. OFF : use settings stored on the print server to start up.	OFF
Switch 2	ON : identify the following automatically at time of print server start-up: 10Base-T/100Base-TX, full-duplex/half-duplex. OFF : use settings of switches 3 and 4 to start up.	ON
Switch 3	ON : start-up100Base- TX OFF : start-up10Base- T	OFF
Switch 4	ON : start up for full-duplex. OFF : start up for half-duplex.	OFF

Note: The settings of switches 3 and 4 are enabled only when switch 2 is OFF.

VIII. MAINTENANCE AND INSPECTION

A. Periodically Replaced Parts

Note: A periodically replaced part is one that must be replaced at certain intervals to ensure a specific level of machine performance. (They must be replaced regardless of the presence/absence of damage, as they will significantly affect the machine operation once they fail.) If possible, schedule the replacement to coincide with a scheduled service visit.

The Printer does not have parts that need periodical replacement.

B. Durables

Some parts of the Printer may require replacement once or more over the product warranty period because of wear or damage. Replace them when they fail.

1. Printer

Table 4-8-1

As of August 2001

No.	Part name	Part No.	Q'ty	Average life	Remarks
1	Cassette pickup roller	FF6-0981-000	1	80,000 pages	Replaced by the user. (Note 1)
2	Cassette separation pad	FB5-8099-000	1	80,000 pages	Replaced by the user. (Note 1)
3	Manual feed pickup roller	FF6-1834-000	1	50,000 pages	(Note 2)
4	Manual feed separation pad	FB5-8028-000	1	50,000 pages	(Note 2)
5	Transfer charging roller	FB5-8019-000	1	150,000 pages (50,000 pages)	The values within parentheses indicate for a room temperature of 15°C less and humidity of 10% or less.

Notes: 1. Be sure to replace the spring (FS7-2593-000) of the cassette separation pad at the same time.
 2. Be sure to replace at the same time.
 3. The above values are estimates only, and are subject to change based on future data.

2. Paper Feeder**Table 4-8-2**

As of August 2001

No.	Part name	Part No.	Q'ty	Average life	Remarks
1	Cassette pickup roller	FF6-0981-000	1	80,000 pages	To be replaced by the user. (Note 1)
2	Cassette separation pad	FB5-8099-000	1	80,000 pages	To be replaced by the user. (Note 1)

Notes: 1. The spring (FS7-2593-000) must be replaced at the same time.

2. The above values are estimates only, and are subject to change based on future data.

C. Scheduled Servicing

The Printer does not have parts that require scheduled servicing.

D. Points to Note for Cleaning

- a. **Cassette Pick Roller, Feeding Roll**
Use lint-free paper and alcohol.
- b. **Manual Feed Pickup Roller**
Use lint-free paper and alcohol. If the user often uses label sheet or the like (apt to leave dirt) for the multimeter, thus causing pickup faults, advise the use of the manual feed tray cleaning tool. (For instructions on how to use the tool, see VII-4 'Manual Feed Pickup Roller' in Chapter 1.)
- c. **Manual feed Separation Pad, Cassette Separation Pad**
Use lint-free paper.
- d. **Transfer Charging Roller**
As a rule, do not touch or clean it. If it must be cleaned, take full care not to touch it or not to leave solvents or oils.
Use lint-free paper (so as not to leave lint), and be sure to dry wipe it. Do not use water or solvent.
- e. **Registration Roller Assembly**
Clean it with lint-free paper. If the dirt is appreciable, use lint-free paper moistened with alcohol for the rubber portion and with solvent for the rest.
- f. **Static Eliminating Brush**
Clean it with a blower brush.

Do not clean the following:

- Photosensitive drum

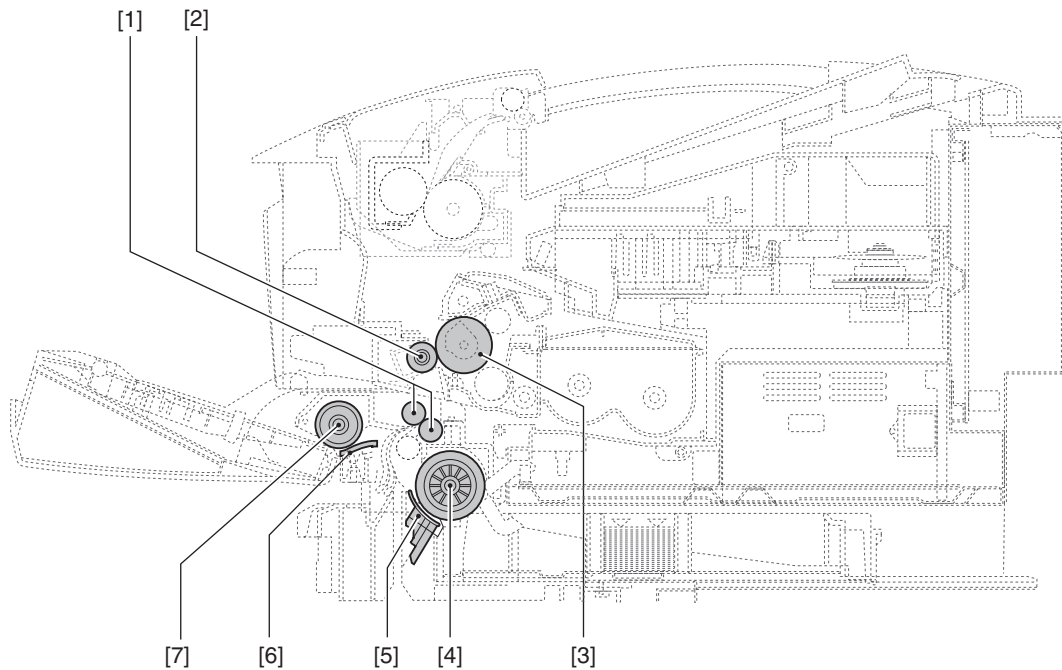

- | | |
|----------------------------------|--------------------------------|
| [1] Registration roller assembly | [5] Cassette separation pad |
| [2] Transfer charging roller | [6] Manual feed separation pad |
| [3] Photosensitive drum | [7] Manual feed pickup roller |
| [4] Cassette pickup roller | |

Figure 4-8-1

E. Standard Tools

You will need the following standard stools when servicing the Printer:

Table 4-8-3

No.	Tool name	Tool No.	Description
1	Tool bag	TKN-0001	
2	Jumper wire	TKN-0069	With a clip.
3	Gap gauge	CK-0057	0.02 to 0.3 mm
4	Spring gauge	CK-0058	For checking spring pressure (0 to 600 g).
5	Phillips screwdriver	CK-0101	M4, M5 Length: 363 mm
6	Phillips screwdriver	CK-0104	M3, M4 Length: 155 mm
7	Phillips screwdriver	CK-0105	M4, M5 Length: 191 mm
8	Phillips screwdriver	CK-0106	M4, M5 Length: 85 mm
9	Flat-blade screwdriver	CK-0111	
10	Flat-blade precision screwdriver set	CK-0114	6 pc. per set.
11	Hex key wrench set	CK-0151	5 pc. per set.
12	Fine-faced file	CK-0161	
13	Hex screwdriver	CK-0170	M4 Length: 107 mm
14	Nippers	CK-0201	
15	Precision pliers	CK-0202	
16	Pliers	CK-0203	
17	Stop ring pliers	CK-0205	For shaft ring.
18	Pressure pliers	CK-0218	
19	Tweezers	CK-0302	
20	Ruler	CK-0303	For measurement (150 mm).
21	Soldering iron	CK-0309	100V, 30W
22	Plastic hammer	CK-0314	
23	Brush	CK-0315	
24	Pen-shaped light	CK-0327	
25	Plastic bottle	CK-0328	100 cc
26	Solder	CK-0329	ϕ 1.5 (mm) \times 1 (mm)
27	Solder drawing wire	CK-0330	1.5 mm
28	Lint-free paper	CK-0336	500SH/PKG
29	Soldering iron	CK-0348	240V, 30W
30	Oil applicator	CK-0349	30 cc
31	Plastic bottle	CK-0351	30 cc
32	Digital multimeter	FY9-2032	

F. Special Tools

You need not obtain tools other than those in the standard tools set.

G. Solvents and Oils

Table 4-8-4

No.	Name	Composition	Uses	Remarks
1	Alcohol	Alcohol, water, surface activating agent	Cleaning: e.g., plastic, rubber.	<ul style="list-style-type: none"> • Do not bring near fire. • Procure locally. • CI or IPA may be substituted.
2	Solvent	Fluorine family hydrocarbon, chlorine family hydrocarbon, alcohol	Cleaning; e.g., metal (oil stains, toner stains).	<ul style="list-style-type: none"> • Procure locally. • Do not bring near fire.
3	Silicone grease	Silicone oil	Lubricating; drive mechanism. (However, do not use on the fixing roller gear.)	<ul style="list-style-type: none"> • Tool No. CK-0551 (20 g).

IX. ARRANGEMENT OF ELECTRICAL PARTS

A. Switches and Sensors

• **Printer**

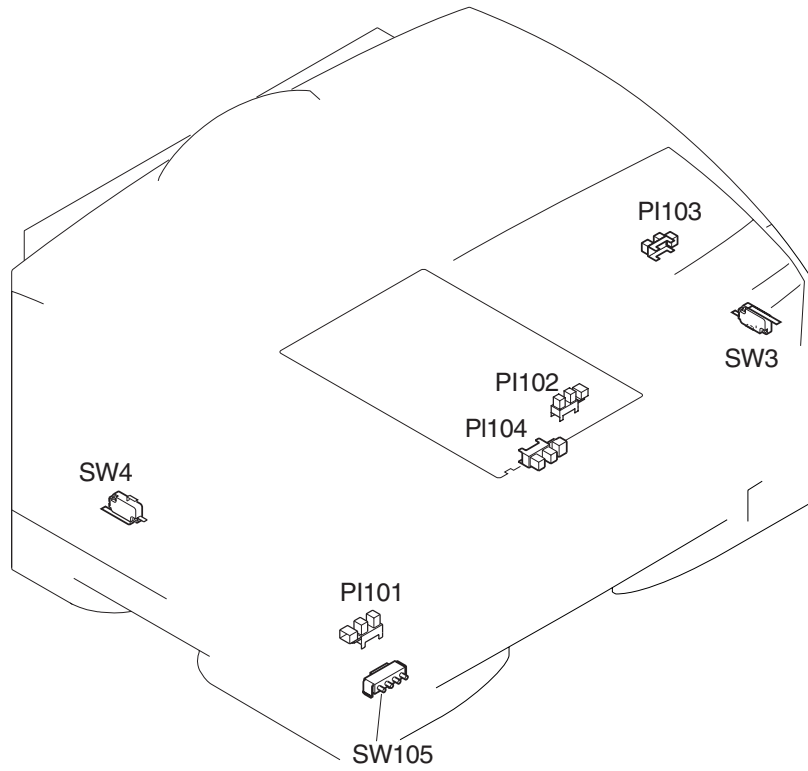

• **Paper feeder**

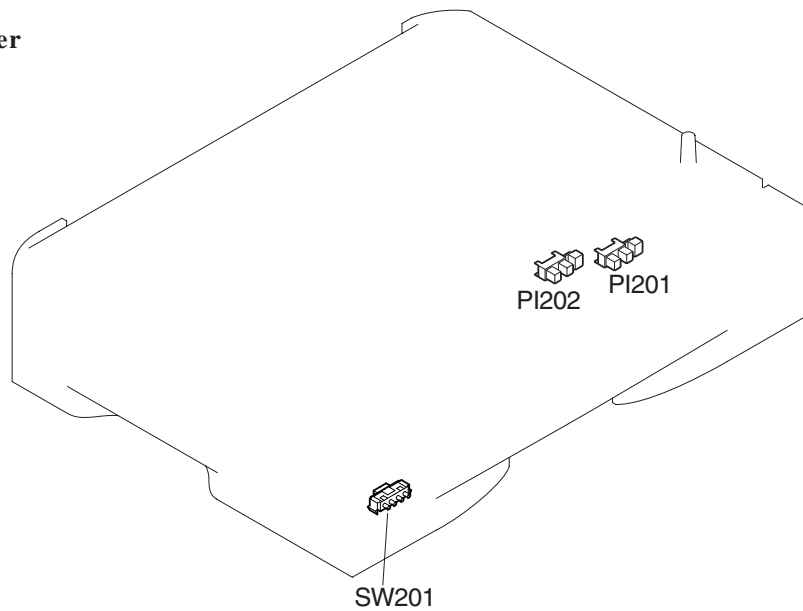



Figure 4-9-1

Table 4-9-1

Symbol	Name	Notation	Description
	Switch	SW3	Right door switch
	Switch	SW4	Left door switch
	Switch	SW105	Cassette paper size detecting switch
	Switch	SW201	Paper feed paper size detecting switch
	Sensor	PI101	Registration paper sensor
	Sensor	PI102	Multifeeder paper sensor
	Sensor	PI103	Delivery sensor
	Sensor	PI104	Cassette paper sensor (DC controller PCB)
	Sensor	PI201	Paper feeder feed paper sensor
	Sensor	PI202	Paper feeder cassette paper sensor

B. Clutches, Solenoids, and Motors

• **Printer**

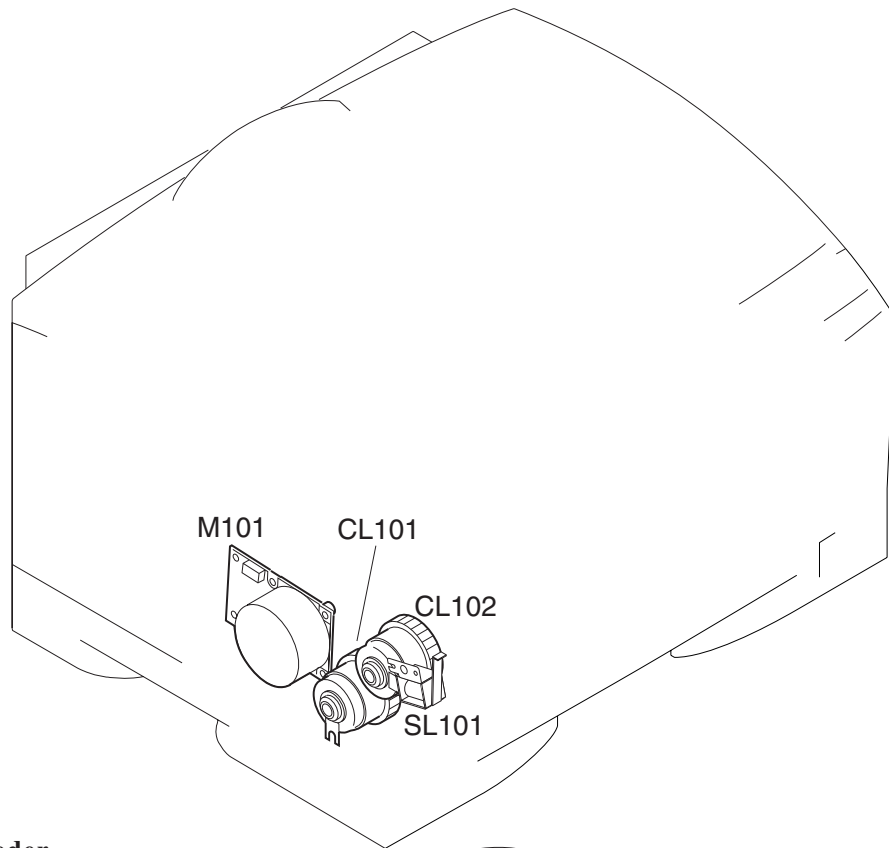

• **Paper Feeder**

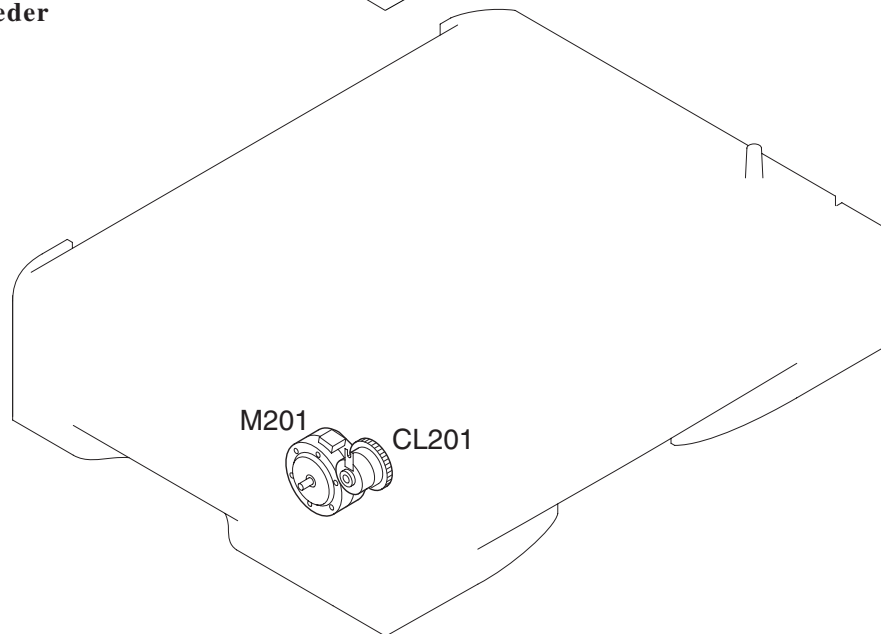
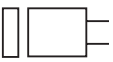



Figure 4-9-2

Table 4-9-2

Symbol	Name	Notation	Description
	Solenoid	SL101	Multifeeder pickup solenoid
	Clutch	CL101	Cassette pickup clutch
	Clutch	CL102	Registration clutch
	Clutch	CL201	Paper feed pickup clutch
	Motor	M101	Main motor
	Motor	M201	Paper feeder pickup motor

C. Others
 • Printer

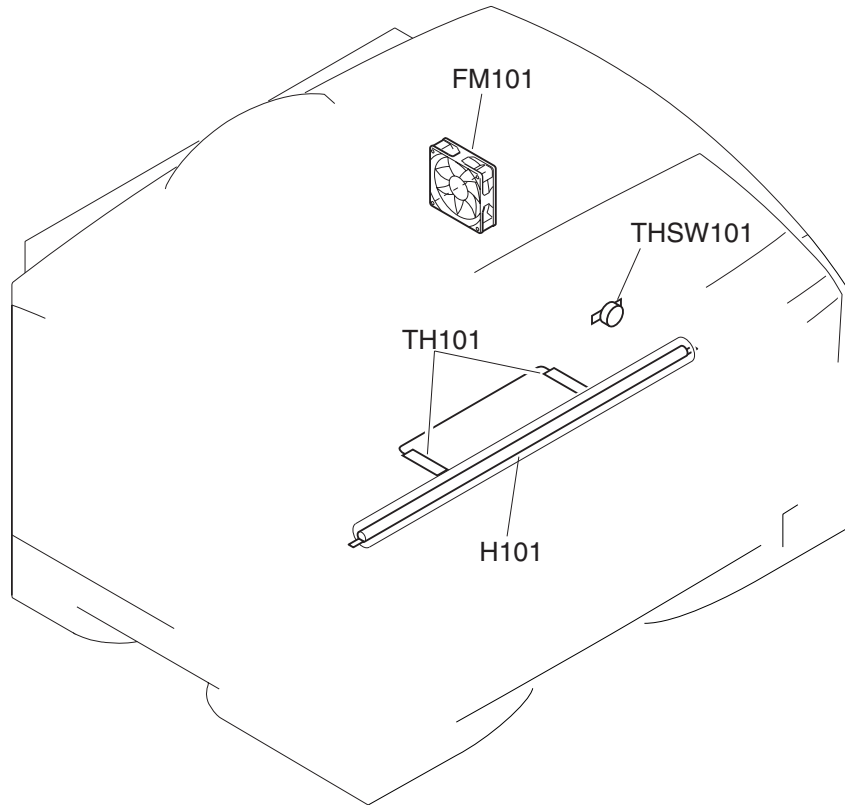







Figure 4-9-3

Table 4-9-3

Symbol	Name	Notation	Description
	Thermistor	TH101	Main thermistor (for detection of temperature at middle of fixing assembly surface)
	Thermistor	TH101	Sub thermistor (for detection of temperature at edges of fixing assembly surface)
	Thermal switch	THSW101	Thermal switch (for detection of error temperature of the fixing roller)
	Fan motor	FM101	Heat discharge fan
	Heater	H101	Fixing heater

D. PCBs

- Printer

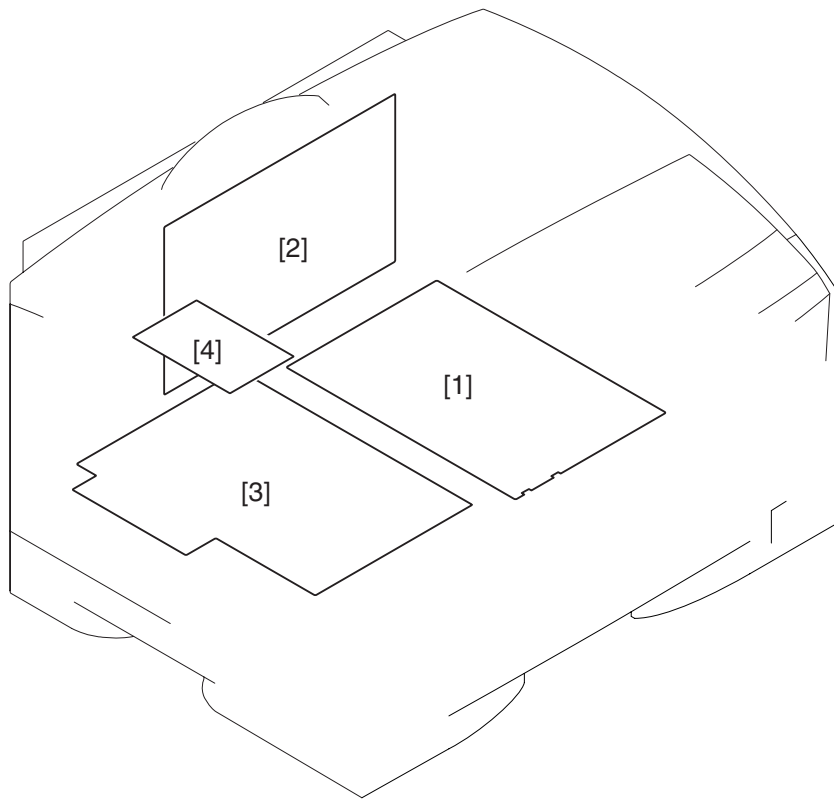

- Paper Feeder

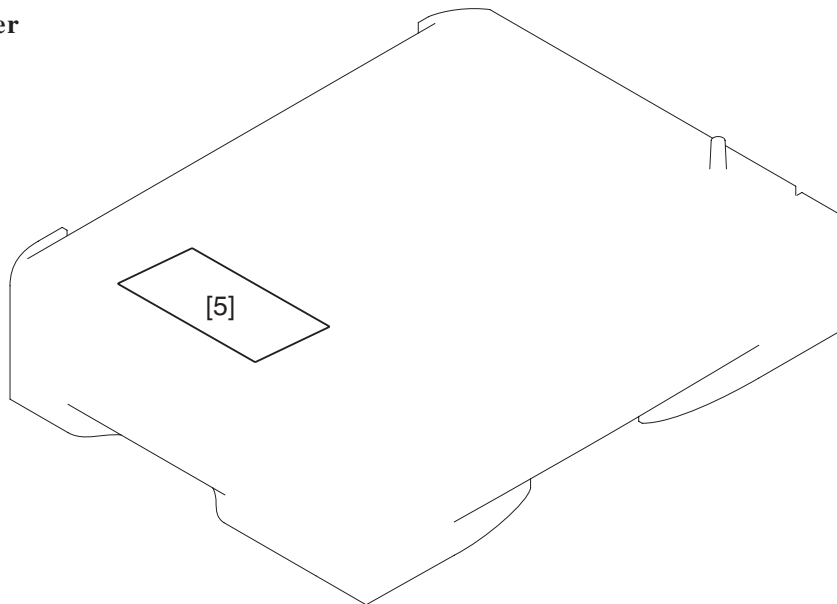

Figure 4-9-4

Table 4-9-4

No.	Name	Description
1	DC controller PCB	DC load control
2	Video controller PCB	Image processing/various interface connections
3	Power supply PCB	DC power supply output
4	Control panel PCB	Control panel key input/LED indication
5	Paper feeder controller PCB	Paper feeder DC load control

E. Connectors
• Printer

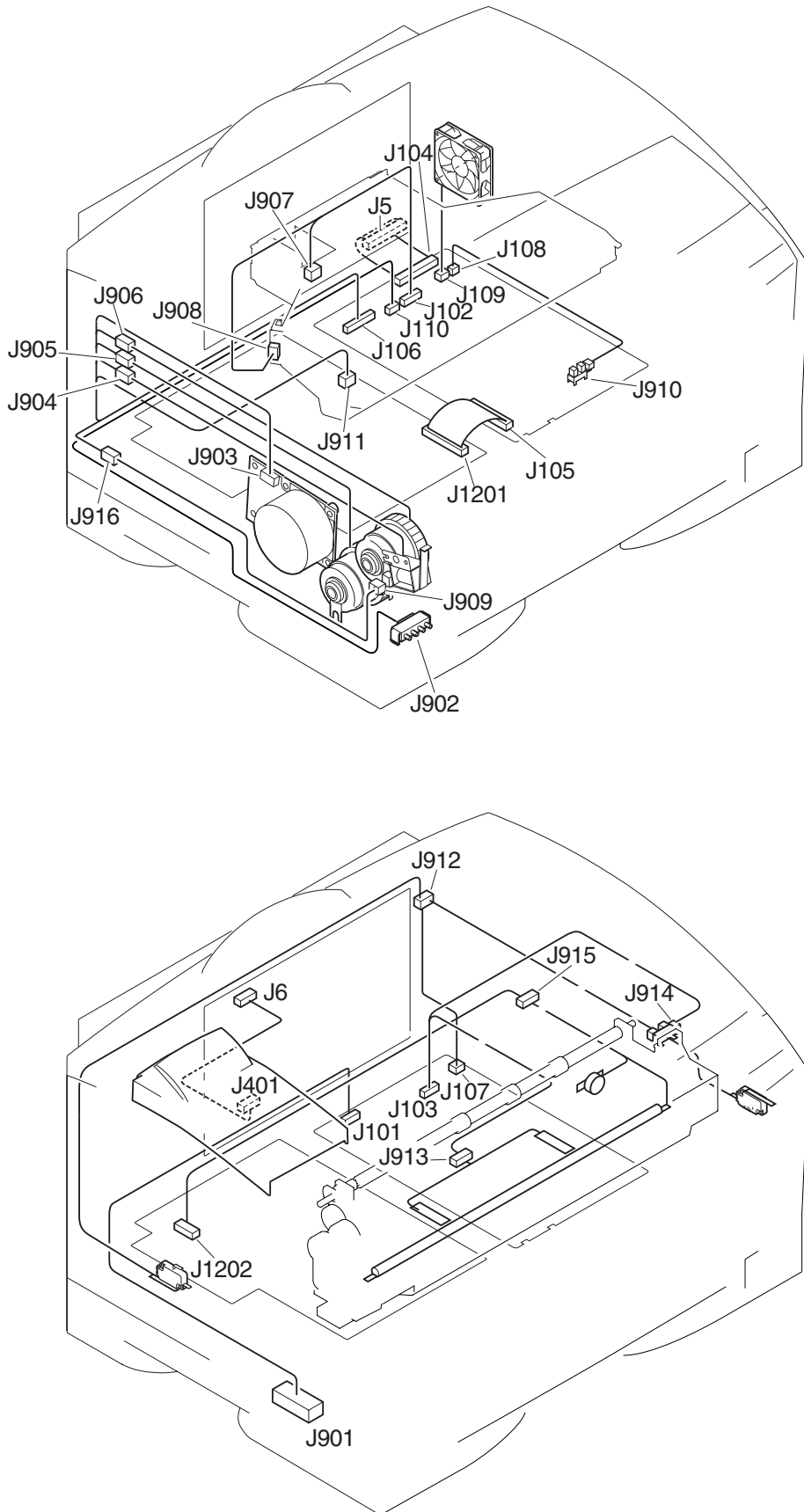

Figure 4-9-5

- Paper feeder

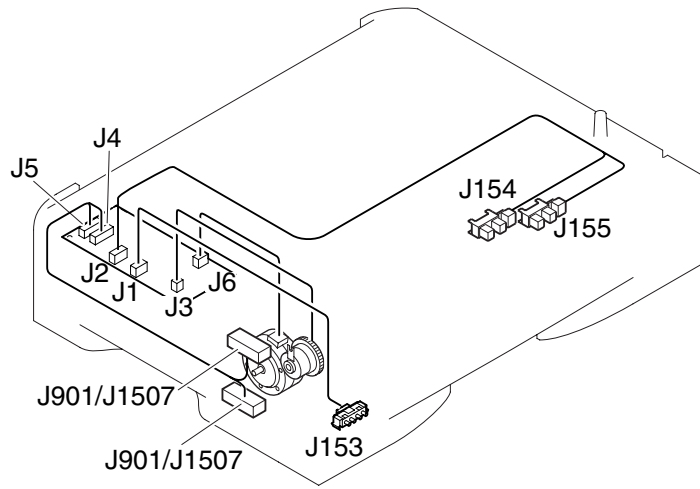

Figure 4-9-6

APPENDIX

I. GENERAL TIMING CHART	A-1	III. LIST OF SIGNALS	A-5
II. GENERAL CIRCUIT DIAGRAM ...	A-3	IV. MESSAGES TABLE	A-10

I. GENERAL TIMING CHART

General Timing Chart (1/1)

- A4, 2 Sheets, Continuous

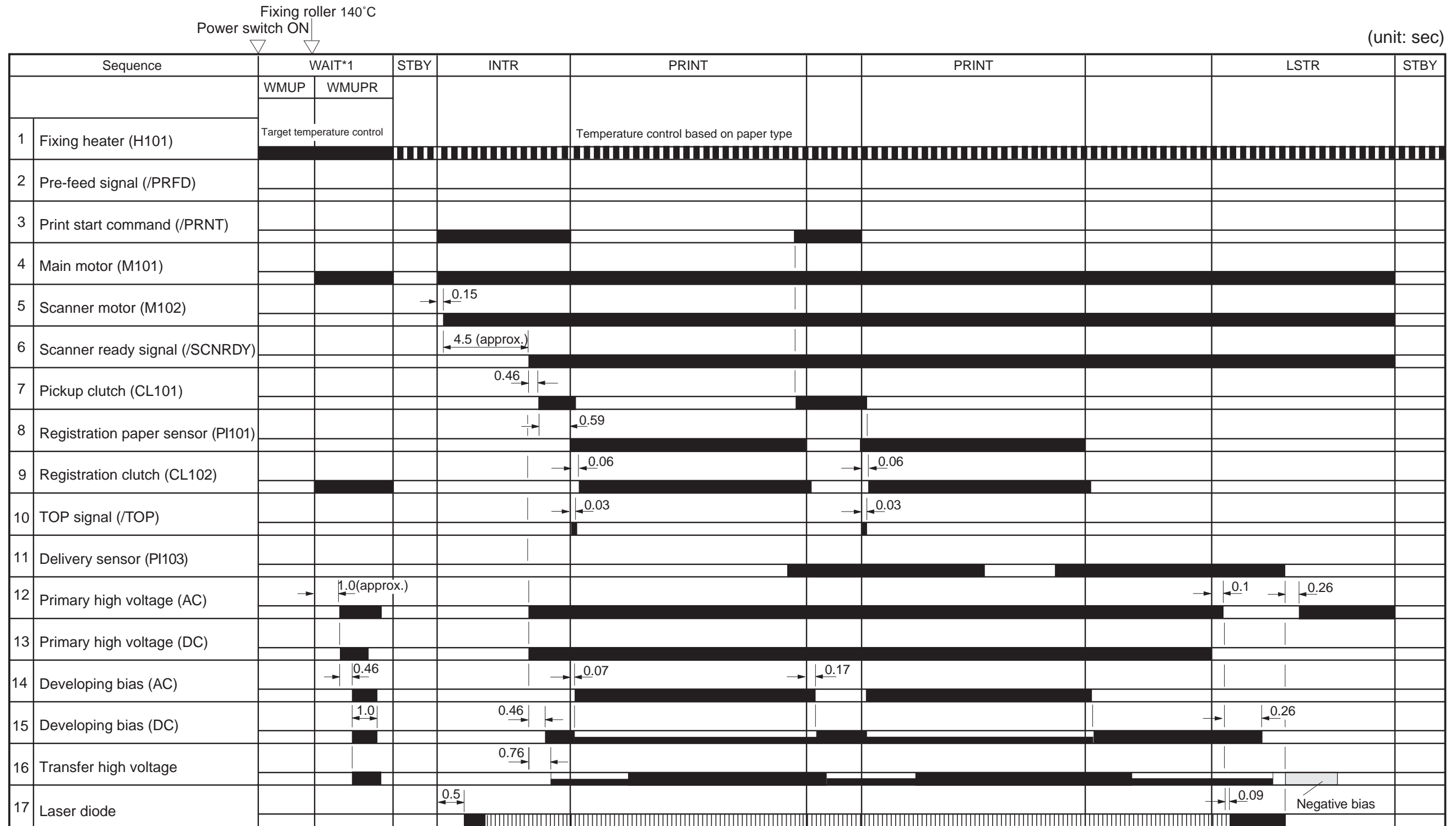

*1: Condition for Shifting to Standby

- 25 sec has passed after the fixing assembly is turned on and, in addition, the fixing assembly temperature is 150°C or higher.
- 27 sec has passed after the fixing assembly is turned on and, in addition, the fixing assembly temperature is 145°C or higher.

II. GENERAL CIRCUIT DIAGRAM

General Circuit Diagram (1/2)

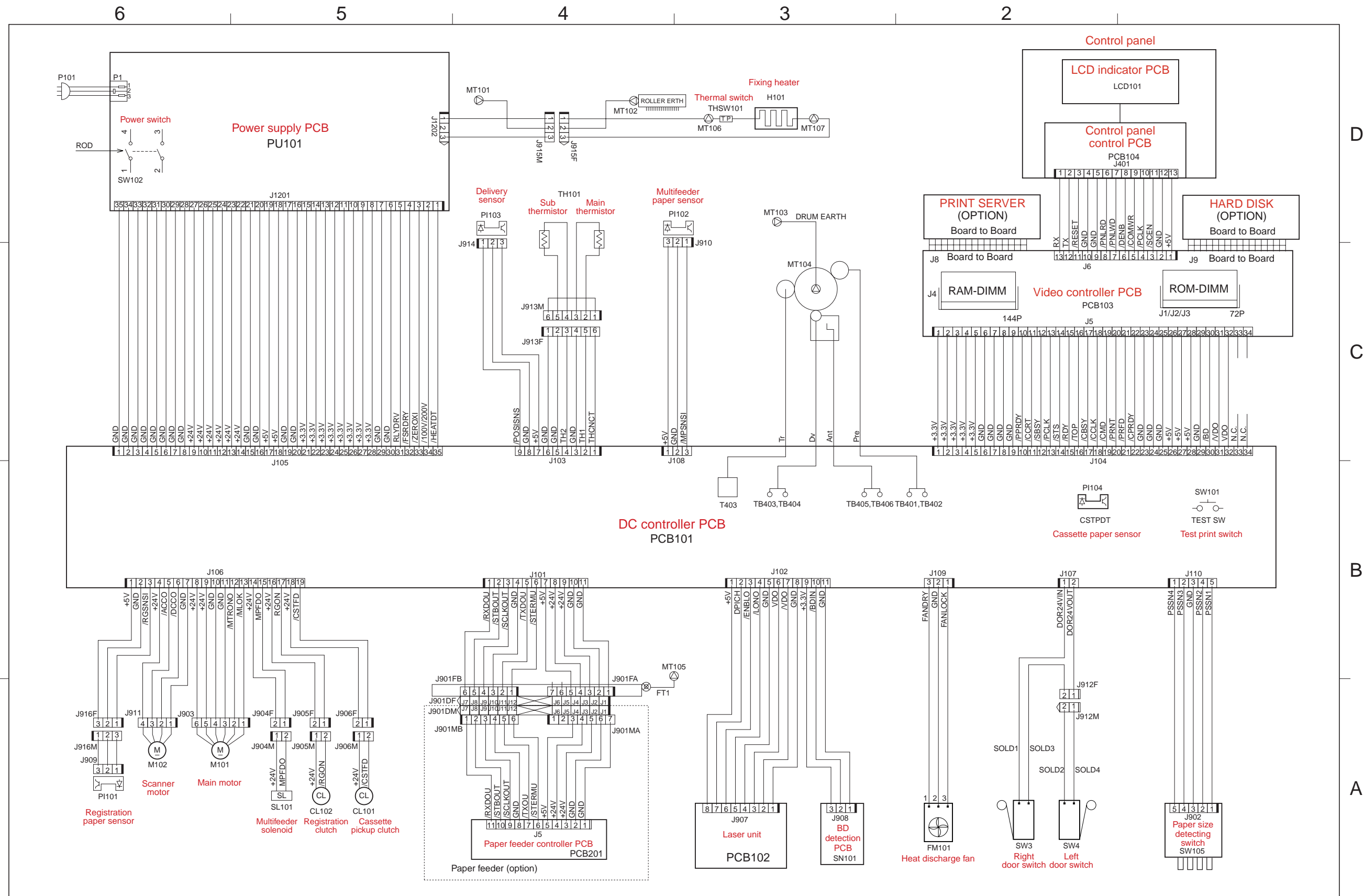

General Circuit Diagram (2/2)

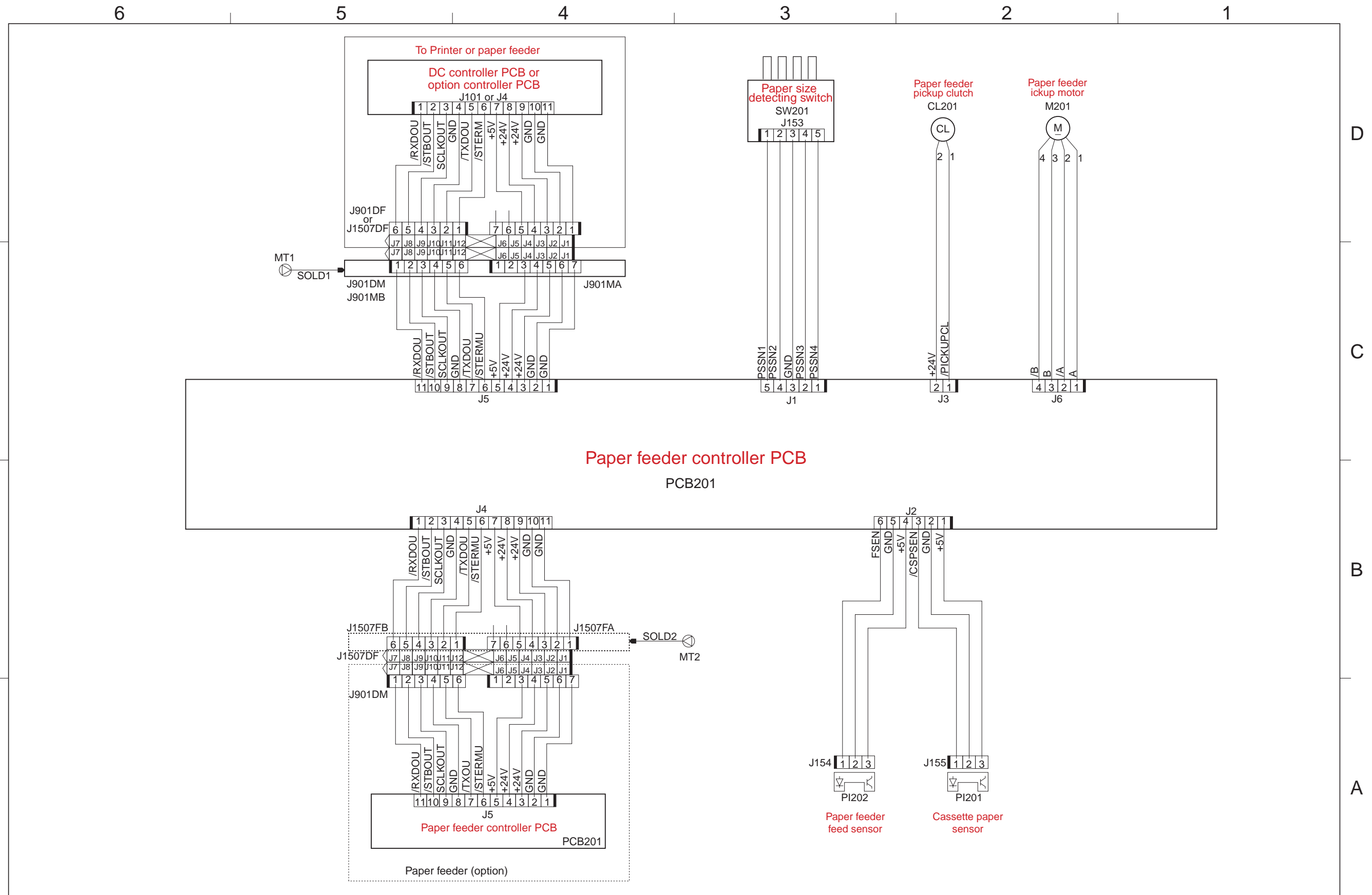

III. LIST OF SIGNALS

A. Inputs to and Outputs from the DC Controller PCB

Connector	Pin	Notation	I/O	Logic	Remarks
J101	1	/RXDO	Input	Pulse	Machine internal communication signal
	2	/STB	Output	L	Strobe signal
	3	/SCLK	Output	Clock	Clock signal
	4	GND			
	5	/TXDO	Output	Pulse	Machine internal communication signal
	6	/STERMU	Output	L	Option select signal
	7	+5V			
	8	+24V			
	9	+24V			
	10	GND			
	11	GND			
J102	1	+5V			
	2	DPICH	Output	H	Fixed to L
	3	/ENBL	Output	L	Image formation enable signal
	4	/LON	Output	L	Laser beam forced emission signal
	5	GND			
	6	VDO	Output	H	Video signal (CCW)
	7	/VDO	Output	L	Video signal (CW)
	8	GND			
	9	+3.3V			
	10	/BDIN	Input	BD	Input signal
	11	GND			
J103	1	THCNCT	Output	H	Connector disconnection detection signal; L: connected
	2	FSRTH1	Input	Analog	Fixing roller temperature detection signal 1
	3	GND			
	4	FSRTH2	Input	Analog	Fixing roller temperature detection signal 2
	5	GND			
	6	GND			
	7	+5V			
	8	GND			
	9	/POSISNS	Input	L	Delivery paper detection signal
J104	1	+3.3V			
	2	+3.3V			
	3	+3.3V			
	4	+3.3V			
	5	+3.3V			
	6	GND			

APPENDIX

Connector	Pin	Notation	I/O	Logic	Signal	
J104	7	GND				
	8	GND				
	9	GND				
	10	/PPRDY	Input	L	Printer power ready signal	
	11	/CCRT	Output	L	State change notice signal	
	12	/SBSY	Output	L	Status busy signal	
	13	/PCLK	Output	Pulse	Printer clock signal	
	14	/STS	Output	L	Status signal	
	15	/RDY	Output	L	Ready signal	
	16	/TOP	Output	L	TOP signal	
	17	/CBSY	Input	L	Command busy signal	
	18	/CCLK	Input	Pulse	Controller clock signal	
	19	/CMD	Input	L	Command signal	
	20	/PRNT	Input	L	Print signal	
	21	/PRFD	Input	L	Pre-feed signal	
	22	/CPRDY	Input	L	Controller power ready signal	
	23	GND				
	24	GND				
	25	GND				
	26	+5V				
	27	+5V				
	28	+5V				
	29	GND				
	30	/BD	Output	Pulse	BD output signal	
	31	/VDO	Input	L	Video signal	
	32	VDO	Input	H	Video signal	
	33	N.C.				
	34	N.C.				
	J105	1	GND			
		2	GND			
		3	GND			
		4	GND			
		5	GND			
		6	GND			
7		GND				
8		GND				
9		+24V				
10		+24V				
11		+24V				
12		+24V				

Connector	Pin	Notation	I/O	Logic	Signal
J105	13	+24V			
	14	+24V			
	15	GND			
	16	GND			
	17	+5V			
	18	+5V			
	19	GND			
	20	GND			
	21	+3.3V			
	22	+3.3V			
	23	+3.3V			
	24	+3.3V			
	25	+3.3V			
	26	+3.3V			
	27	+3.3V			
	28	+3.3V			
29	GND				
30	GND				
31	RLYDRV	Output	H	Relay drive signal	
32	/FSRDRV	Output	H	Fixing heater drive signal	
33	/ZEROXI	Input	L	Zero-cross signal	
34	/100/200V	Input	L	AC power supply input identification signal (H: 100V model, L: 200V model)	
35	/HEATDT	Input	L	Fixing heater activation detection signal	
J106	1	+5V			
	2	GND			
	3	/RGSNS	Input	L	Registration paper sensor
	4	+24V			
	5	/ACCO	Output	L	Scanner motor acceleration signal
	6	/DCCO	Output	L	Scanner motor deceleration signal
	7	GND			
	8	+24V			
	9	+24V			
	10	GND			
	11	GND			
	12	MTRON	Output	H	Main motor drive signal
	13	/MLOK	Input	L	Main motor rotation detection signal
	14	+24V			
	15	MPFD	Output	H	Multifeeder pickup solenoid drive signal
	16	+24V			

APPENDIX

Connector	Pin	Notation	I/O	Logic	Signal
J106	17	RGON	Output	H	Registration clutch drive signal
	18	+24V			
	19	CSTFD	Output	H	Cassette pickup clutch drive signal
J107	1	DOR24VIN	Input	H	Front door open/closed detection signal
	2	DOR24VOUT	Output	H	Front door open/closed detection signal
J108	1	+5V			
	2	GND			
	3	/MPSNSJ	Output	L	Multifeeder paper detection signal
J109	1	FANDRV	Output	H	Fan drive signal
	2	GND			
	3	FANLOCK	Input	H	Fan lock signal
J110	1	PSSN4	Input		Cassette paper size 4 detection signal
	2	PSSN3	Input		Cassette paper size 3 detection signal
	3	GND			
	4	PSSN2	Input		Cassette paper size 2 detection signal
	5	PSSN1	Input		Cassette paper size 1 detection signal

B. Inputs to and Outputs from the Paper Feeder Controller PCB

Connector	Pin	Notation	I/O	Logic	Signal
J 1	1	PSSN4	Input		Cassette paper size 4 detection signal
	2	PSSN3	Input		Cassette paper size 3 detection signal
	3	GND			
	4	PSSN2	Input		Cassette paper size 2 detection signal
	5	PSSN1	Input		Cassette paper size 1 detection signal
J 2	1	+5V			
	2	GND			
	3	/CSPSEN	Input		Cassette paper sensor detection signal
	4	+5V			
	5	GND			
	6	FSNE	Input		Paper feeder paper sensor detection signal
J 3	1	+24V			
	2	/PICKCL	Output	L	Cassette pickup clutch drive signal
J 4	1	/RXDOU	Input	Pulse	Machine internal communication signal
	2	/STBOUT	Output	L	Strobe signal
	3	SCLKOUT	Output	Clock	Clock signal
	4	GND			
	5	/TXOU	Output	Pulse	Machine internal communication signal
	6	/STREMU	Output	L	Options select signal
	7	+5V			
	8	+24V			
	9	+24V			
	10	GND			
	11	GND			
J 5	1	GND			
	2	GND			
	3	+24V			
	4	+24V			

IV. MESSAGES TABLE

a. JUST MESSAGE

Message	Meaning	Action
WARMING UP...	The printer is warming up.	The printer will be ready in a moment.
READY	The printer is online.	The printer is ready to print.
PRINTING	Printing...	The printer is printing.
PAUSED	The printer is offline.	Press the Go key on the printer to start printing.
READY FLUSHING	The printer is canceling the print job.	Wait a moment for the operation to complete.
CLEANING PAGE	The printer is printing a cleaning page.	Wait a moment for the operation to complete.
RESTORING DEFAULTS	The printer is restoring the factory defaults.	Wait a moment for the operation to complete.
PASSWORD CHANGED	The password is being changed.	Wait a moment for the operation to complete.
I/O INITIALIZING	Initializing the feed/output options.	Wait a moment for the operation to complete.
TOTAL: ### SMALL: ###	Impression counts are displayed.	The total impression count of the printer, and the total page count of small-sized and large -sized paper printed are displayed on the control panel.
SMALL: ### LARGE: ###		
LARGE: ### TOTAL: ###		
READY # OF %	The copy function is being used.	Wait a moment for the operation to complete.
JOB IN PROGRESS +CANCEL/-COUNT	The printer is being shutdown during a print job process.	Press the Value key to cancel shutdown on the printer, or press the Shift and Value keys to continue.
SAFE TO TURN OFF PRINTER	Ready to turn off the printer.	Turn off the printer.
COOLING DOWN	The fuser unit is being cooled down.	Wait a moment for the operation to complete.
CLEANING	Multi-Purpose tray's roller is being cleaned.	Wait a moment for the operation to complete.
POWER SAVER ON	The power saver mode is being activated.	The printer will start warming up again as soon as you send a job or press a key.

b. SERVICE CALL ERROR

Message	Meaning	Action
E000 CALL FOR SERVICE	A fuser error occurred.	Perform the troubleshooting procedure described in Section VI of Chapter 4.
E001 CALL FOR SERVICE	A fuser overheating error occurred.	
E003 CALL FOR SERVICE	A fuser low-temperature error occurred.	
E011 CALL FOR SERVICE	A motor error occurred.	
E110 CALL FOR SERVICE	A scanner error occurred.	
E676 CALL FOR SERVICE	A communication error occurred between the controller and the printer	
E677/6F-61 CALL FOR SERVICE	An internal ROM check error occurred.	
E677/6F-63 CALL FOR SERVICE	An internal RAM error occurred.	
E677/6F-7A CALL FOR SERVICE	An SRAM error occurred in the ASIC.	
E805 CALL FOR SERVICE	A fan motor error occurred.	
E808 CALL FOR SERVICE	A fuser error occurred in the drive circuit.	

c. WARNING MESSAGE

Message	Meaning	Action
READY TONER LOW	The toner is low.	Remove the toner cartridge, slowly shake it 5-6 times, and then replace it. If this message is displayed again, replace the current toner cartridge with a new one.
KEY NOT VALID	A button that is not enabled in the current function is pressed.	Press the correct key to complete the current function.
MEMORY OVERFLOW	A memory overflow has occurred.	The printer has received more data than it can hold in the available memory on the printer. If AUTOCONT is ON (CONFIG MENU), the print job will be put back online after 10 seconds. If AUTOCONT is OFF, the printer will go offline. Measure 1: Press the Go key and the print job will continue printing, although data may be lost. Measure 2: Simplify the print job by deleting unnecessary fonts or macro files from the printer memory, or add additional memory to the printer.
FLASH OVERFLOW	A memory overflow has occurred in the optional Flash ROM.	The printer has received more font and macro data than it can hold in the available memory of the Flash ROM. The printer will go offline. Measure 1: Press the Go key to put the printer back online. Measure 2: Format the Flash ROM or delete font and macro files to create more space.
MRT COMPRESSION	Processing complex data.	The printer is using MRT Compression because the page is too complex. Wait a moment for the operation to complete.
DISK ALMOST FULL	The optional hard disk is 70% or more full.	Delete any font or macro files that are no longer needed to increase the amount of available disk space.
DISK FULL	The optional hard disk is 95% full, and the printer will go offline.	The printer will be put back online after 10 seconds, if AUTOCONT is ON (CONFIG MENU). Delete any fonts or macro files that are no longer needed to increase the amount of available disk space.
READY JOB LOG FULL	The amount of stored job logs will exceed the maximum limit.	Delete unnecessary job logs from the printer hard disk.
READY NEAR STORE LIMIT	The number of stored print jobs will exceed the maximum of 9500.	Delete unnecessary print jobs from the printer hard disk.

d. NORMAL ERROR

Message	Meaning	Action
TONER CART MISSING	No toner cartridge is installed.	Install the toner cartridge, and then press the Go key on the printer.
LOAD <size> IN <trays>	Out of paper.	Load paper into printer.
LOAD <size> IN MANUAL	Out of paper.	Load paper into Multifeeder Tray.
LOAD CLEANING PAGE IN MANUAL	Cleaning the fixing assembly.	Load the Multifeeder tray with the Cleaning Page generated by the printer. Then, press the Go key to feed the Cleaning Page.
PAPER JAM CHECK INPUT	Paper jam.	There is a paper jam in the paper feeding area of the printer. Remove the jammed paper, and then press the Go key on the printer.
PAPER JAM CHECK OUTPUT	Paper jam.	There is a paper jam near the paper output area of the printer. Remove the jammed paper, and then press the Go key on the printer.
PAPER JAM OPEN FRONT COVER	Paper jam.	There is a paper jam near the upper cover of the printer. Remove the jammed paper, and then press the Online key on the printer.
CASSETTE1 MISSING	Cassette 1 is not in the printer or is not correctly positioned.	Install Cassette 1 in the printer. If the paper cassette is in the printer, remove it, insert it again and ensure it is securely in position.
CASSETTE2 MISSING	Cassette 2 is not in the printer or is not correctly positioned.	Install Cassette 2 in the printer. If the paper cassette is in the printer, remove it, insert it again and ensure it is securely in position.
CASSETTE3 MISSING	Cassette 3 is not in the printer or is not correctly positioned.	Install Cassette 3 in the printer. If the paper cassette is in the printer, remove it, insert it again and ensure it is securely in position.
PRINTER OPEN	The front cover is open.	Close the front cover, and then press the Go key on the printer.
WRONG PAPER SIZE	A paper size mismatch has occurred.	More than one paper size has been found in the same tray. Inspect the trays for mismatched paper and correct.
USER ID ERROR	The user ID is not registered.	Enter the user ID.
AUTHENTICATION ERROR	Invalid password	Enter the correct password.
EXCEEDS STORE LIMIT	Unable to save print job on the printer hard disk	There is not enough available free space on the printer hard disk. Delete unnecessary print jobs from the printer hard disk, and then, press the Go key on the printer.
PS OPTION ERROR	A optional PS ROM error occurred.	An optional PS ROM has failed the startup checksum. Replace the optional PS ROM.
OPTION RAM ERROR	An optional RAM error occurred.	An optional RAM has failed the startup diagnostic. Replace the optional RAM.
OPTION ROM ERROR	An optional ROM error occurred.	An optional ROM has failed the startup checksum. Replace the optional ROM.

Message	Meaning	Action
FLASH ERROR	The optional Flash ROM error occurred.	Replace the optional Flash ROM.
WRITING DISK ERROR	Unable to write to the printer hard disk.	Measure 1: Make sure that the printer hard disk is installed correctly. Measure 2: Turn off the printer, and the turn it on again. Measure 3: Format the printer hard disk.
READING DISK ERROR	Unable to read the printer hard disk.	Measure 1: Make sure that the printer hard disk is installed correctly. Measure 2: Turn off the printer, and the turn it on again. Measure 3: Format the printer hard disk.
MEM ALLOC ERROR	Not enough memory to process the data and print the page.	If AUTOCONT is ON (CONFIG MENU), the printer will be put back online after 10 seconds. If AUTOCONT is OFF, press the Go key to put the printer back online. Check the printed page to ensure that the print job is complete.
PARALLEL INTERFACE ERROR	A parallel port error occurred.	Perform the troubleshooting procedure described in Section VI of Chapter 4.
USB INTERFACE ERROR	An USB port error occurred.	
ETHERNET OPTION ERROR	An Extended Interface error occurred.	
JOB STORING REJECTED	The receiving print job will stop.	The amount of stored job logs will exceed the maximum limit. Delete unnecessary job logs from the printer hard disk.

e. The following messages are displayed on the SERVICE mode.

Message	Meaning	Action
NVRAM OK	All NVRAMs work correctly.	
NVRAMx ERROR	An error occurred in the NVRAMx.	Reinstall or replace the NVRAM.
WRITING NVRAMx ERROR	A writing error occurred in the NVRAMx.	Replace the NVRAM.
CHECK NVRAM	Incorrect information has been found in the NVRAM.	Replace the NVRAM.
+REALLY/-IGNORE x -> y	Duplicate page counter information from the NVRAMx to the NVRAMy?	Select + (press the Value key) to continue duplication, or select - (press the Shift and Value keys) to cancel the operation.
+ FORMAT DISK - IGNORE DISK	Format the printer hard disk?	Select + (press the Value key) to continue, or select - (press the Shift and Value keys) to cancel.
+ REALLY FORMAT - IGNORE DISK	The operator is being asked to verify the disk formatting is really wanted. This is in response to the foregoing message.	Press + to verify that the disk is to be formatted or press - to skip formatting the disk. This message will not display for new/unformatted disk (e.g. The disk is to be formatted for the 1st time)
START DISK TEST	Start the hard disk test?	Press the Enter/Cancel key to begin testing the printer hard disk. To stop the disk test, press the Enter/Cancel key again. Once the test is stopped, you will be asked to FORMAT DISK after printer restarts.
ENTER ENDS TEST	Stop the hard disk test?	Press the Enter/Cancel key to end testing the printer hard disk. The printer will automatically restart to format the hard disk.
FORMATTING...	The printer hard disk is being formatted.	Wait a moment for the operation to complete.
DSK FMT RESTART	The printer hard disk has been formatted.	Press the Enter key to restart the printer.
+ FORMAT FLASH - IGNORE FLASH	Format the optional Flash ROM?	Select + (press the Value key) to continue, or select - (press the Shift and Value) to cancel.
+ REALLY FORMAT - IGNORE FLASH	Continue formatting the optional Flash ROM?	Select + (press the Value key) to begin formatting the Flash ROM, or select - (press the Shift and Value keys) to cancel the operation.
FLASH FORMAT RESTART	The optional Flash ROM has been formatted. The printer will restart.	Wait a moment for the operation to complete.
FLASH FORMATTING...	The optional Flash ROM is being formatted.	Wait a moment for the operation to complete.
+ REALLY CLEAR - IGNORE CLEAR	Clear the device password?	Select + (press the Value key) to clear the device password, or select - (press the Shift and Value keys) to cancel the operation.
DONE	The operation of clearing a password or error flag of engine NVRAM has done successfully.	
FAILED	The operation of clearing a password has failed.	

f. The following messages are displayed as the HIDDEN function.

Message	Meaning	Action
COLD RESET A4	The printer is performing a cold reset with A4 to restore the factory default settings.	Wait a moment for the operation to complete.
COLD RESET LTR	The printer is performing a cold reset with Letter to restore the factory default settings.	Wait a moment for the operation to complete.
PANEL CHECK	Panel check is being performed.	Wait a moment for the operation to complete.
PANEL CHECK DONE	Panel check has been complete.	The printer will restart.

Prepared by
Consumer Imaging Products Quality Assurance Dept.1
Consumer Imaging Products Quality Assurance Div
Office Imaging Products Quality Assurance Center

CANON INC.

REVISION 0 (AUG. 2001)

5-1, Hakusan 7-chome, Toride-shi, Ibaraki 302-8501, Japan

Canon